

Rapid Frequency Response Measurement of Power Conversion Products with Coherence-Based Confidence Analysis

Tomi Roinila, *Student Member, IEEE*, Aki Taskinen and Matti Vilkkö, *Member, IEEE*

Abstract—Switched-mode converters play now a significant role in modern society. Their operation are often crucial in various electrical applications affecting the every day life. Therefore, the quality of the converters needs to be reliably verified. Recent studies have shown that the converters can be fully characterized by a set of frequency responses which can be efficiently used to validate the proper operation of the converters. Consequently, several methods have been proposed to measure the frequency responses fast and accurately. Most often correlation-based techniques have been applied. The presented measurement methods are highly sensitive to external errors and system nonlinearities. This fact has been often forgotten and the necessary uncertainty analysis of the measured responses has been neglected. This paper presents a simple approach to analyze the noise and nonlinearities in the frequency-response measurements of switched-mode converters. Coherence analysis is applied to form a confidence interval characterizing the noise and nonlinearities involved in the measurements. The presented method is verified by practical measurements from a high-frequency switched-mode converter.

Keywords—Switched-mode converters, Frequency analysis, Coherence Analysis.

I. INTRODUCTION

SWITCHED-mode converters have become extensively used in modern society. The yearly production of the converters is several hundreds of millions of units, and the markets are global and growing. The supplies are widely used to provide power conversion for applications ranging from computing and communications [1] to medical electronics [2], appliance control [3], transportation [4], high-power transmission [5], and renewable energy systems [6–8]. Consequently, the wide and increasing application area of power converters has posed new challenges for converter design and research both in industry and academy. The converters have to meet the operational requirements but still fulfil the strict international energy efficiency standards and specifications which have become more stringent over the years. Early efficiency regulations were typically very uncomplicated targeting only standby or no-load power consumption. Nowadays the programs such as Energy Star^R cover multiple operational modes of typical use in an effort to improve overall efficiency [9].

The competition in the power supply markets has naturally forced the manufacturers to minimize the material costs and consequently, the most low-cost components are used in converter production. It may be obvious, however, that very

often the low-cost components do not satisfy tight parameter tolerances. Usually the converters are highly sensitive to the variation of the parameter values and thus, the designed operation of a converter may be compromised yielding unpredicted behavior or even instability. As a consequence, the powered device does not work as specified, and worst, will be damaged or destroyed. Even though the converter operates dynamically as designed, a large amount of the used energy may be wasted energy caused by bad components.

Another challenge in converter production is found from the fact that the markets of electrical devices, particularly the consumer products, are characterized by shortening product life cycles [10]. Thus, there is pressure to get the product through the development cycle at ever quicker rates. Because the converters and their topologies have become highly complex, the extensive studies and time-consuming quality tests cannot be comprehensively performed during the design and production. Thus, a need exists for a high-throughput testing method to evaluate the product quality.

Recent studies indicate that frequency-domain characterization gives most useful information of the converter dynamics and quality [11–13]. It has been shown that the converters can be characterized by a certain set of transfer functions which are typically measured as frequency responses. The prevailing technique to obtain the responses has been the use of a sine-sweep-based frequency-response analyzer [14, 15]. However, the technique is characterized by a long time taken by the measurements and thus, the analyzer cannot be effectively used in measuring hundreds or thousands of converters. Correlation-based techniques with broad-band excitation sequences have been introduced lately to be used instead of the conventional analyzer [16–27]. The techniques are based on a broadband excitation sequence which is injected into a device. The corresponding output response is measured and analyzed in order to obtain the system characterizing frequency response. The recently proposed methods reduce the time of the measurement cycle from minutes to seconds compared to the conventional method.

The previously presented frequency-response-measurement techniques are characterized by a high sensitivity to external noise and nonlinearities. Thus, appropriate noise and nonlinearity analysis should play a significant role in the measurement procedures. This has been most often forgotten. This paper presents a simple analyzing tool to obtain the information of the noise and nonlinear characteristics of the measured frequency responses. Coherence analysis is applied

T. Roinila, M. Vilkkö and A. Taskinen are with the Department of Automation Science and Engineering, Tampere University of Technology, Finland, P.O. Box 692, FIN-33101, e-mail: firstname.lastname@tut.fi.

to form a confidence interval characterizing the noise and nonlinearities involved in the measurements. The presented method can be applied in various frequency-response-based analyzing tools of switched-mode converters and can be easily extended for other electrical circuits as well.

The rest of the paper is organized as follows. A frequency-response-computation method is presented in Section II. Section III introduces the Dirac-ideal MLBS excitation which is used in the measurement procedure. The coherence analysis to evaluate the noise and nonlinear characteristics of the measured response is introduced in Section IV. Experimental evidence based on a high-frequency switched-mode converter is presented in Section V supporting the theoretical findings. Finally, the conclusions are drawn in Section VI.

II. MEASURING FREQUENCY RESPONSE

A switched-mode converter can be considered to be a linear, time-invariant system up to half the switching frequency [28]. According to basic control theory, this type of system can be fully characterized by its impulse response in time domain, which can be transformed to the frequency domain and presented as frequency-response function (FRF) [29].

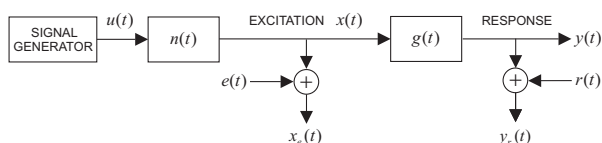

Fig. 1. Typical FRF-measurement arrangement.

Fig.1 shows a typical FRF-measurement set up where the device under test (DUT), presented by the system impulse-response function $g(t)$, is to be identified. The designed excitation $u(t)$ is first processed (filtered and amplified by $n(t)$) yielding the actual excitation $x(t)$. The DUT is then perturbed with $x(t)$ yielding the corresponding output response $y(t)$. The measured input and output signals are corrupted with noise, presented by $e(t)$ and $r(t)$, respectively. The measured excitation and output response can be denoted by $x_e(t)$ and $y_r(t)$. The noises are assumed to resemble white noise and being uncorrelated with $x(t)$ and $y(t)$. All the signals are assumed to be zero mean sequences.

The system FRF $G(j\omega)$ can be denoted by

$$G(j\omega) = \frac{Y(j\omega)}{X(j\omega)} \quad (1)$$

where $Y(j\omega)$ and $X(j\omega)$ represents the output and input spectra obtained by the Fourier transform of the corresponding time-domain signals $y(t)$ and $x(t)$. In the presence of external noise, the measured FRF $G_m(j\omega)$ can be denoted by

$$G_m(j\omega) = \frac{Y_r(j\omega)}{X_e(j\omega)} \quad (2)$$

where $X_e(j\omega)$ and $Y_r(j\omega)$ represents the Fourier transforms of $x_e(t)$ and $y_r(t)$. Denoting the error signals $e(t)$ and $r(t)$ by their Fourier transforms $E(j\omega)$ and $R(j\omega)$, the measured

FRF becomes

$$G_m(j\omega) = G(j\omega) \frac{1 + [R(j\omega)/Y(j\omega)]}{1 + [E(j\omega)/X(j\omega)]} \quad (3)$$

The presence of external noise may affect the measurement procedure substantially causing low signal-to-noise ratio (SNR). The latter part of the right hand side in (3) may hence become very small or large yielding an inaccurate FRF estimate. In this paper, a logarithmic averaging procedure is proposed to overcome this problem and can be presented as [30]

$$G_{\log}(j\omega) = \left(\prod_{k=1}^N \frac{Y_r(j\omega)_k}{X_e(j\omega)_k} \right)^{1/N} \quad (4)$$

where N denotes the number of periods of the excitation signal. Under certain SNR-requirements the procedure tends to neglect the effect of measurement noise both at input and output and provides a FRF estimate with a very small systematic error. The only requirement in (4) is that the excitation signal must imitate white noise, i.e. its auto correlation must resemble Dirac delta function.

III. DIRAC-IDEAL MLBS EXCITATION

The excitation signals can be divided into binary [31], near-binary [32], and non-binary signals [33]. Because the power converters are generally highly sensitive to the external signals, the injected excitation signal must have low amplitude but at the same time as much power as possible. The binary signals follow this requirement by having a low peak factor [34] and hence, they can be considered to be most suited excitations for power converters.

One of the most popular periodic binary sequence is pseudo-random binary sequence (PRBS). One special class of these signals is maximum length binary sequence (MLBS). PRBS $\{a_k\}$ is a maximum length binary sequence (MLBS) if, and only if, it satisfies a linear recurrence

$$a_k = \sum_{i=1}^n c_i a_{k-i} \pmod{2} \quad (5)$$

and has a period length of $P = 2^n - 1$, where c_i has a value of 0 or 1 [35]. In practice, the values 0 and 1 are mapped to -1 and +1 to produce a symmetrical MLBS with an average close to zero. The auto-correlation function $\phi_{\text{MLBS}}(n)$, and power spectrum $\Phi_{\text{MLBS}}(\omega)$ of MLBS are illustrated in Figs.2 and 3 where a denotes the signal amplitude, N the signal length and Δt the signal pulse width.

Fig.2 shows, that the ACF of the MLBS does not follow exactly the Dirac delta function, thus yielding a bias error to the measured FRF [36]. Usually the excitation is selected to be adequately long and therefore the bias error can be considered to be negligible. However, if only a narrow-band properties of a converter is to be identified, it may be useful to use a short excitation sequence in order to reduce the measurement time and increase the SNR. Thus, the bias error may become unacceptably large.

One method to produce a signal with ideal ACF properties is to use a near-binary sequence, such as ternary signal [36].

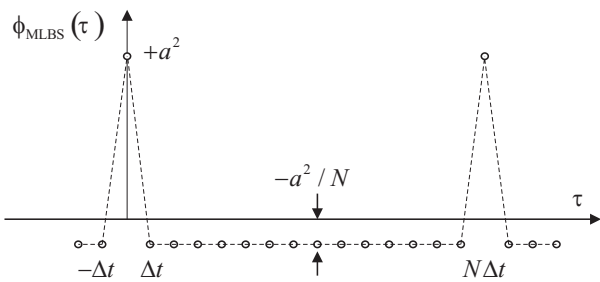

Fig. 2. Shape of auto-correlation function of MLBS.

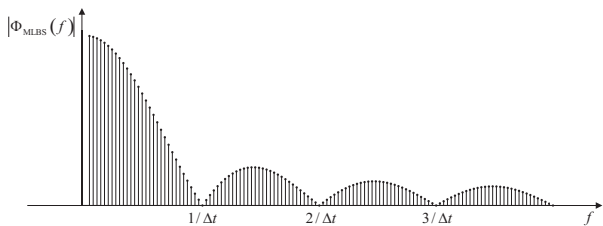

Fig. 3. Shape of power spectrum of MLBS.

The other method is to adjust the signal levels of the standard and symmetric MLBS to produce an asymmetric MLBS. Due to the attractive properties of the binary sequences, the latter technique is preferred for switched-mode converters. The symmetric signal refers to a sequence whose maximum value is the opposite of the minimum value. In the asymmetric signal the sequence maximum value differs from the opposite of the minimum value.

The authors in [37] derived the asymmetric MLBS to be

$$u_{\text{asymm}} = \sqrt{\frac{N}{N+1}} \left[u_{\text{symm}} + \frac{-a \pm \sqrt{N+1}}{N} \right] \quad (6)$$

where u_{symm} denotes the standard and symmetric MLBS, a its maximum value and N the signal length. The asymmetric MLBS can have two different forms, depending on the selection of plus-minus sign. The resulting asymmetric MLBS has the ACF of

$$\phi_{uu}(\tau) = \begin{cases} 1, & \tau = 0 \\ 0, & \tau = 1, 2, \dots, N-1 \end{cases} \quad (7)$$

The ACF of the asymmetric MLBS follows exactly the Dirac delta function and the sequence is known as Dirac-ideal MLBS (D-MLBS). Using the D-MLBS the bias error in the measured frequency response caused by the excitation can be fully avoided. The D-MLBS excitation was used the first time for the power converters in [38].

IV. COHERENCE ANALYSIS

A measure often used to quantify the quality of the measured FRF is the coherence defined for the periodic signals as

[39]

$$\gamma^2(\omega_k) = \frac{\left| \frac{1}{R} \sum_{l=1}^R Y_{rk}^{[l]}(k) X_{ek}^{*[l]}(k) \right|^2}{\left(\frac{1}{R} \sum_{l=1}^R |X_{ek}^{*[l]}(k)|^2 \right) \left(\frac{1}{R} \sum_{l=1}^R |Y_{rk}^{[l]}(k)|^2 \right)} \quad (8)$$

where the asterisk denotes complex conjugate and R the number of excitation periods. The coherence measures how much the output power is coherent with the input power. The coherence value can be shown to be between 0 and 1. The value of smaller than 1 indicates the presence of extraneous noise in the measurements or nonlinear distortions. The mapping of (8) can be conveniently used to form a confidence interval around the measured frequency response. In this paper the confidence values $\alpha(\omega_k)$ are computed as

$$\alpha(\omega_k) = \pm \gamma^2(\omega_k) \cdot 100\% \quad (9)$$

i.e. the confidence values approach 0 % as the coherence goes to zero, and 100 % as the coherence goes to one.

V. EXPERIMENTAL VERIFICATION

The proposed identification method was experimentally tested and verified by measuring the frequency response of closed-loop output impedance from a 300W computer power supply (3.7 $V_{dc}/30$ A) having a switching frequency of 100 kHz. Fig. 4 illustrates the conceptual diagram of the measurement system. The FRF measurement was carried out by using a PC, National Instruments PCI-6115 measurement card with a 12-bit ADC, linear amplifier, injection transformer, Tektronix current measurement kit, electronic load, and *Matlab* with *Data Acquisition*-toolbox software. The conceptual diagram of the designed frequency-response analyzer (FRA) and the measurement system for the output impedance is shown in Fig.4. The excitation signal, generated by the PC, is digitally filtered and injected through the measurement card (MC), linear amplifier and injection transformer into the selected input of the device under test (DUT), and the response is measured at the selected output.

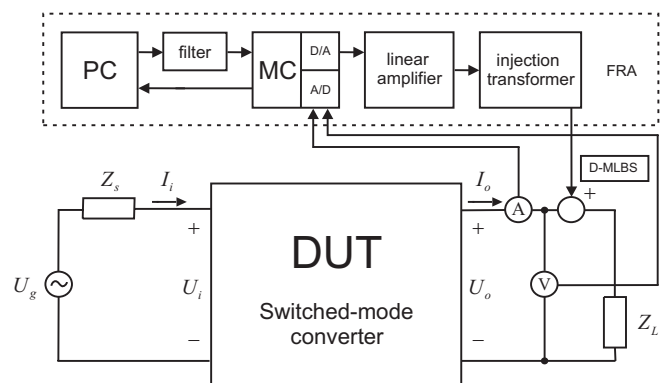

Fig. 4. Conceptual diagram of frequency-response-measurement procedure of closed-loop output impedance.

The excitation sequence was designed as shown in detail e.g. in [38]. A 4095-bit-length MLBS was applied with a

generation frequency of 70 kHz. The sequence was modified by (6) to produce an excitation with Dirac-ideal properties. The designed excitation was then injected into output current with ten periods and the output voltage was measured. The frequency response was computed using (4). Fig. 5 shows the measured bode plot of the closed-loop output impedance of the converter. The measurement procedure took less than two seconds including excitation injection. Fig. 6 shows the coherence values of the measured frequency response when (8) is applied.

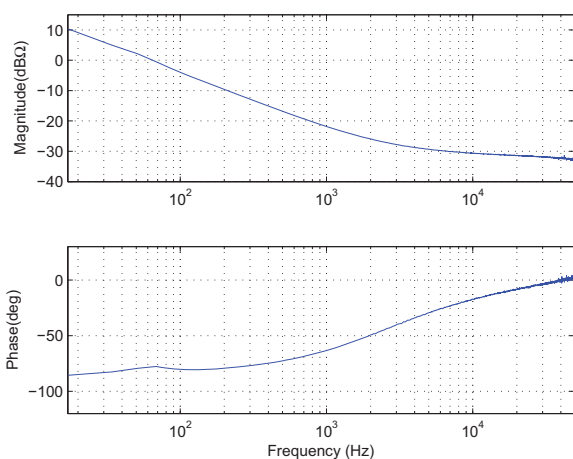

Fig. 5. Measured frequency response.

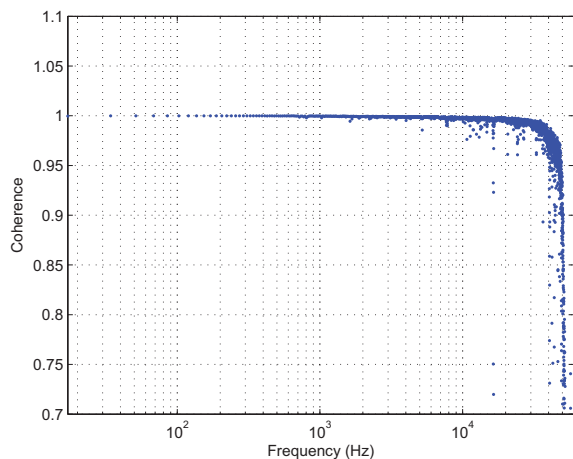

Fig. 6. Coherence of the measured frequency response.

Fig. 7 shows a sample of the measured gain function with the coherence interval when (9) is applied. It is emphasized that the numerical values of the coherence interval do not coincide with the magnitude values. To facilitate the illustration and analysis, intervals of 85 % and 90 % coherence levels are drawn. As the figure shows, the system exhibits relatively strong nonlinear and noise characteristics particularly at high frequencies. The coherence interval can be used in various

ways, e.g. in selecting the outliers from the measured data.

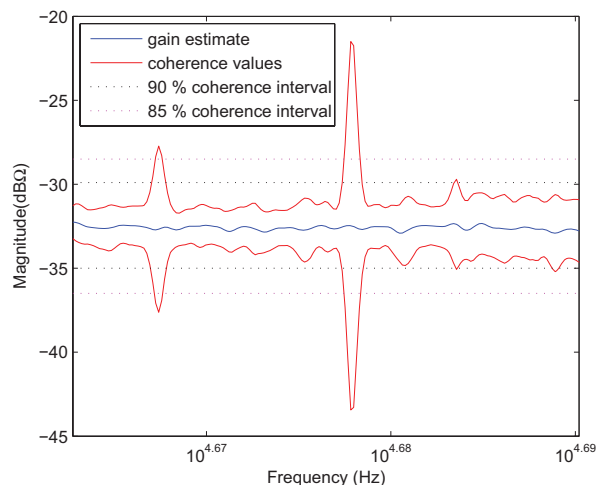

Fig. 7. Sample of measured gain function with confidence interval.

VI. CONCLUSION

Non-parametric frequency-response-identification methods have become popular during the last years and their potentiality have been fully recognized also in the power electronics field. Recent studies have yielded a number of low-cost implementations to be used for measuring the transfer functions of switched-mode converters thus characterizing their dynamics.

The presented FRF-measurement procedures of the power converters are typically highly sensitive to external noise and nonlinearities. This has been often forgotten and necessary uncertainty analyses have not been performed. This paper presented a simple approach to analyze the noise and nonlinear characteristics in the measured frequency responses by applying coherence analysis. The coherence values are used to form a certain confidence interval around the measured response thus describing the system noise and nonlinear characteristics. In addition, the paper reviewed the basics behind the non-parametric system identification and showed the steps to measure the frequency response of a switched-mode converter applying Dirac-ideal MLBS excitation. The proposed methods were verified by experimental measurement from a high-frequency switched-mode converter.

The proposed methods in this paper can be applied in various ways in analysis of switched-mode converters. Possible applications could be, for instance, controller design, system validation and quality assessment. The method is well suited for both on-line and off-line analysis. It is also emphasized that even though the discussion in this paper is focused on the switched-mode converters, the proposed methods are naturally applicable to similar measurements applied to other electrical circuits and linear systems.

REFERENCES

- [1] M. Sayani and J. Wanes, "Trends and drivers in isolated board-mounted DC/DC products for communications ap-

- plications,” in *Proc. IEEE Applied Power Electronics Conference and Exposition*, 2003, pp. 37–41.
- [2] S. Mobin, H. Takano, and M. Nakaoka, “Simulation of series-parallel resonant DC-DC converter system with DSP based digital control scheme for medical X-ray use,” in *Proc. IEEE Industry Applications Conference*, 1999, pp. 1048–1055.
- [3] S. Madani and M. Shahbazi, “A soft-switching hybrid BLDC drive using dc-dc converter,” in *Proc. IEEE International Electric Machines and Drives Conference*, 2009, pp. 1290–1294.
- [4] A. Khaligh, S. Williamson, and A. Emadi, “Control and stabilization of DC/DC buck-boost converters loaded by constant power loads in vehicular systems using a novel digital scheme,” in *Proc. International Power Electronics and Motion Control Conference*, 2006, pp. 1769–1775.
- [5] M. Ehsani, L. Laskai, and M. Bilgic, “Topological variations of the inverse dual converter for high power DC-DC applications,” in *Proc. IEEE Industry Applications Society Annual Meeting*, 1990, pp. 1262–1266.
- [6] K. Kobayashi, H. Matsuo, and Y. Sekine, “Novel solar-cell power supply system using a multiple-input DC-DC converter,” *IEEE Trans. on Industrial Electronics*, vol. 53, no. 1, pp. 281–286, 2006.
- [7] L. Palma and P. Enjeti, “A modular fuel cell, modular DC-DC converter concept for high performance and enhanced reliability,” in *Proc. IEEE Power Electronics Specialists Conference*, 2007, pp. 2633–2638.
- [8] S.-H. Song, S.-I. Kang, and N.-K. Hahm, “Implementation and control of grid connected AC-DC-AC power converter for variable speed wind energy conversion system,” in *Proc. IEEE Applied Power Electronics Conference and Exposition*, 2003, pp. 154–158.
- [9] “Energy star program requirements for displays 5.0,” 2009, available: <http://www.eu-energystar.org>.
- [10] R. Calantone and C. D. Benedetto, “Performance and time to market: Accelerating cycle time with overlapping stages,” *IEEE Trans. on Engineering Management*, vol. 47, pp. 232–244, 2000.
- [11] T. Suntio, *Dynamic Profile of Switched-Mode Converter*. Wiley-VCH Verlag GmbH and Co. KGaA, Weinheim, 2009.
- [12] T. Roinila, M. Hankaniemi, T. Suntio, M. Sippola, and M. Vilkkö, “Dynamical profile of a switched-mode converter - reality or imagination,” in *Proc. IEEE International Telecommunications Energy Conference*, 2007, pp. 420–427.
- [13] T. Suntio, M. Hankaniemi, and T. Roinila, “Dynamical modelling of peak-current-mode-controlled converter in continuous conduction mode,” *Simulation Modelling Practice and Theory*, vol. 15, pp. 1321–1337, 2007.
- [14] K. Natarajan and M. Yektaei, “Modeling of DC-DC buck converters for large-signal frequency response and limit cycles,” *IEEE Trans. on Circuits and Systems*, vol. 53, pp. 712–716, 2006.
- [15] R. Ridley, “Frequency response measurements for switching power supplies,” in *Unitrode Design Seminar*, 1999.
- [16] B. Miao, R. Zane, and D. Maksimovic, “A modified cross-correlation method for system identification of power converters with digital control,” in *Proc. IEEE Power Electronics Specialists Conference*, 2004, pp. 3728–3733.
- [17] —, “System identification of power converters with digital control through cross-correlation methods,” *IEEE Trans. on Power Electronics*, vol. 20, no. 5, pp. 1093–1099, 2005.
- [18] —, “Practical identification of DC-DC converter dynamic responses,” in *Proc. Applied Power Electronics Conference and Exposition*, 2005, pp. 57–62.
- [19] —, “Automated digital controller design for switching converters,” in *Proc. IEEE Power Electronics Specialists Conference*, 2005, pp. 2729–2735.
- [20] —, “FPGA-based digital network analyzer for digitally controlled SMPS,” in *Proc. IEEE COMPEL Workshop*, 2006, pp. 240–245.
- [21] A. Barkley and E. Santi, “Improved online identification of switching converters using digital network analyzer techniques,” in *Proc. IEEE Power Electronics Specialists Conference*, 2008, pp. 891–896.
- [22] M. Shirazi, J. Morroni, A. Dolgov, and D. Maksimovic, “Integration of frequency response measurement capabilities in digital controllers for DC-DC converters,” *IEEE Trans. on Power Electronics*, vol. 23, no. 5, pp. 2524–2535, 2008.
- [23] A. Barkley and E. Santi, “Online monitoring of network impedances using digital network analyzer techniques,” in *Proc. Applied Power Electronics Conference and Exposition*, 2009, pp. 440–446.
- [24] —, “Improved online identification of a DC/DC converter and its control loop gain using cross-correlation methods,” *IEEE Trans. on Power Electronics*, vol. 24, pp. 2021–2031, 2009.
- [25] T. Roinila, T. Helin, M. Vilkkö, T. Suntio, and H. Koivisto, “Circular correlation based identification of switching power converter with uncertainty analysis using fuzzy density approach,” *Simulation Modelling Practice and Theory*, vol. 17, pp. 1043–1058, 2009.
- [26] T. Roinila, M. Vilkkö, and T. Suntio, “Fast loop gain measurement of switched-mode converter using binary signal with specified Fourier amplitude spectrum,” *IEEE Trans. on Power Electronics*, vol. 17, no. 6, pp. 2746–2755, 2009.
- [27] —, “Fast frequency response measurement of switched-mode converter in the presence of nonlinear distortions,” in *Proc. IEEE Energy Conversion Congress and Exposition*, 2009, pp. 3014–3020.
- [28] T. Suntio, M. Karpanen, and M. Hankaniemi, “Analysing the dynamics of regulated converters,” *IEE Proc. Electronic Power Applications*, vol. 153, no. 6, pp. 905–910, 2006.
- [29] L. Ljung, *System Identification-Theory for the User*. Prentice Hall PTR, USA, 1999.
- [30] K. Godfrey, *Perturbation Signals for System Identification*. Prentice Hall, UK, 1993.
- [31] K. R. Godfrey, “Introduction to binary signals used in

- system identification,” in *Proc. International Conference on Control*, 1991, pp. 161–166.
- [32] A. Tan and K. Godfrey, “The generation of binary and near-binary pseudo-random signals: An overview,” *IEEE Trans. on Instrumentation and Measurement*, vol. 51, no. 4, pp. 583–588, 2002.
- [33] K. R. Godfrey, “Introduction to non-binary signals used in system identification,” in *Proc. International Conference on Control*, 1991, pp. 550–555.
- [34] D. Wulich, “Comments on the peak factor of sampled and continuous signals,” *IEEE Communications Letters*, vol. 4, no. 7, pp. 213–214, 2000.
- [35] S. Golomb, *Shift Register Sequences*. San Francisco, Holden-Day, 1967.
- [36] R. Lang, M. Hutchison, and H. Yee, “Microprocessor-based identification system applied to synchronous generators with voltage regulators,” *Proc. IEE on Generations, Transmissions and Distribution*, vol. 130, pp. 257–265, 1983.
- [37] S. Lesecq and A. Barraud, “A PRBS with exactly zero correlation and its application,” in *Proc. 16th Mediterranean Conference on Control and Automation*, 2008, pp. 724–728.
- [38] T. Roinila, M. Vilkkö, and A. Taskinen, “Improved fast frequency response measurement of switched-mode power supplies using Dirac-ideal PRBS excitation,” in *Proc. International Conference on Adaptive Science and Technology*, 2009, pp. 175–181.
- [39] R. Pintelon and J. Schoukens, *System Identification - A Frequency Domain Approach*. Institute of Electrical and Electronics Engineers, Inc., 3 Park Avenue, New York, 2001.