

Performance Evaluation of the Post-Installed Anchor for Sign Structure

Wooyoung Jung, Minho Kwon, Jinsup Kim, and Buseog Ju

Abstract—Numerous experimental tests for post-installed anchor systems drilled in hardened concrete were conducted in order to estimate pull-out and shear strength accounting for uncertainties such as torque ratios, embedment depths and different diameters in demands. In this study, the strength of the systems was significantly changed by the effect of those three uncertainties during pull-out experimental tests, whereas the shear strength of the systems was not affected by torque ratios. It was also shown that concrete cone failure or damage mechanism was generally investigated during and after pull-out tests and in shear strength tests, mostly the anchor systems were failed prior to failure of primary structural system. Furthermore, 3D finite element model for the anchor systems was created by ABAQUS for the numerical analysis. The verification of finite element model was identical till the failure points to the load-displacement relationship specified by the experimental tests.

Keywords—Post-installed anchor, Pull-out test, Shear test; Torque , ABAQUS.

I. INTRODUCTION

THE safety expectation towards the infrastructure rapidly increased due to in part, by the higher land use and the improvement of living standard. The infrastructure of the society remains the same as the ones from the past, despite of increased safety expectation.

Currently, the routine maintenance and the awareness of threats, in preparation for any disaster of these existing facilities, are insufficient. In addition, as the concrete structures are becoming more complex, connecting element systems of steel-to-concrete or concrete-to-concrete in various ways becomes the mainstream structure complex. Inevitably, the interests towards the method to connect those systems increased significantly. Among all the methods available, the connecting system with the anchor was one of the methods of interest.

Post-installed anchor system is applied to the anchorage zone of the structure, result in supporting a fixed steel structure and/or many devices. It is especially resistant to the combined various loading conditions. Any possible failure behavior of the anchorage zone in the post-installed anchor system could affect

the safety of the whole structure. Examples of failure behavior include the expansion due to the external loads or internal heat, or cracking due to drying shrinkage of concrete structural system. Therefore, the complete understanding of the behavior towards post-installed anchorage system is essential for safe and affordable design. Many of these experimental studies have been progressed actively especially in the U.S and in Europe and elsewhere. ACI (1978) proposed a method to calculate the resistance capacity of this anchor system, assuming that the fracture occurs on the basis of tensile strength of concrete fracture along the conical projection later, Jensen and Braestrup (1976) attempted the improved design equation by introducing a correction factor for the effect of specimen size.[9]-[11] Recently presented CCD (Concrete Capacity Design) theory focused on concrete fracture design methodology in reflection of analyzed data from a numerous European and American theory. The previous research on the pullout of post-installation of the anchor as well as the shear strength capacity subjected to the complex loading conditions could not directly applied to the current anchorage structural systems due to lack of sufficient experimental data in Korea. Therefore, this study focused on evaluating the performance and identifying capacity characteristics of the post-installed anchor systems using various torque conditions, the diameters of the anchor, and the optimal depth of the anchor as a function of uncertainty parameters. The analytical model and engineering demand parameters for this study were also determined by ABAQUS, which was a general-purpose structural finite element analysis platform simulating the destruction of these anchors and concrete structure system.

II. BACKGROUND: ANCHOR SYSTEM

A. Variety of Anchors

Load applied to the connect member were passed to anchor through the friction, the mechanical locking device, attached or by the combination of such factors, and these loads passed to anchor were passed through the primary structural systems. The mechanism of load transfer of anchor was determined by the characteristics of these various complexities.

As shown in Fig. 1, all anchors were classified into two groups: cast-in-place anchor and post-installed anchor, and were classified further according to the basic load transfer mechanism.[6] The recognition of the validity of anchor is widespread, therefore, many design method approach had been conducted in other countries. While US used the ACI 349-85 design standard, and European countries used the CCD

Wooyoung Jung is with Dept. of Civil Engineering, Kangnug-Wonju National University, Gangneung, South Korea (e-mail: wooyoung@gnu.ac.kr).

Minho Kwon is with Dept. of Civil Engineering, Gyeongsang National University, Jinju, South Korea (phone: +82-55-772-1796; fax: +82-55-772-1799; kwonm@gnu.ac.kr).

Jinsup Kim is with Dept. of Civil Engineering, Gyeongsang National University, Jinju, South Korea (e-mail: jskim0330@gmail.com).

Buseog Ju is with Disaster Prevention Research Center, Kangnung-Wonju National University, Gangneung, South Korea. (e-mail: buseogju@gmail.com).

approach proposed by Germany, only few studies were published in this area of research in Korea. Therefore, this research is in desperate need in Korea.

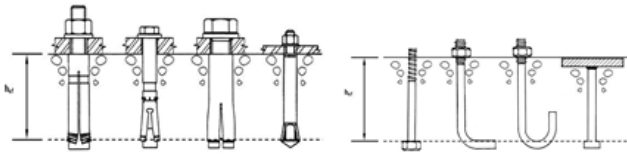

Fig. 1 Variety of Post-Installed Anchor

B. Anchor System Failure Mechanism

The failure modes subjected to tensile loading conditions of the anchor, as shown in Fig. 2[8], include the anchor steel failure, pullout destruction, destroy the concrete cone, and the destruction of splitting. Besides the failure mechanism under the shear, (see Fig. 3) showed in the form of the failure of the anchor steel, concrete pry-out fracture mechanism, and the rupture of concrete, and the various destruction patterns can be seen based on the shear strength of anchor systems and effect of center-to-center distance between adjoining anchor systems.

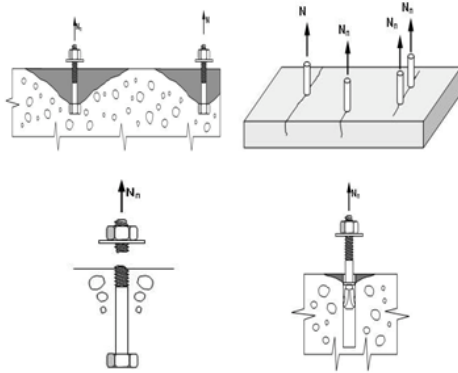

Fig. 2 Tensile Failure Mechanism for Post-Installed Anchor Systems

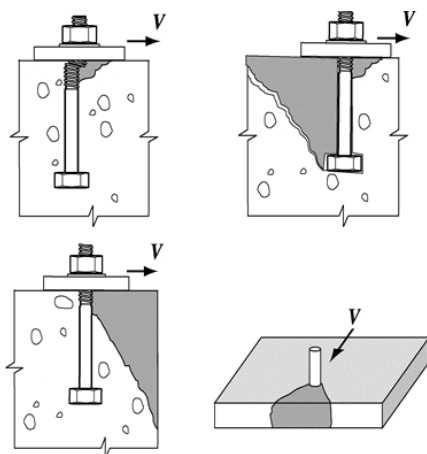

Fig. 3 Shear Failure Mechanism for Post-Installed Anchor Systems

III. EXPERIMENTAL TEST OF THE ANCHOR SYSTEMS

First, post-installed anchor system drilled/installed in

hardened concrete requires design tension and shear strength to avoid creep performance corresponding to tension load and probability for fatigue-related creaking. Therefore, this experimental test was targeted on the shear performance of the anchor system installed in hardened concrete that did not develop the cracks.

A. Testing Instrumentation

Load and displacement measuring devices should be able to collect the data at least once per two second, in order to obtain a continuous load versus displacement curve. In particular, the record before it reaches the maximum load should be clearly recorded. The equipment also should be able to measure the vertical movement of the anchor from the point, which was not affected by deflection, destruction of anchor or structural uncertainty during the experiment. The test setup for post-installed anchor systems drilled in hardened concrete to identify their capacity characteristics due to engineering demand parameters such as embedment depths and torque conditions as a function of uncertainties was shown in Fig. 4. Linear Variable Differential Transformers (LVDT) were installed to anchor in order to obtain sufficient data to specify load-displacement relationship.

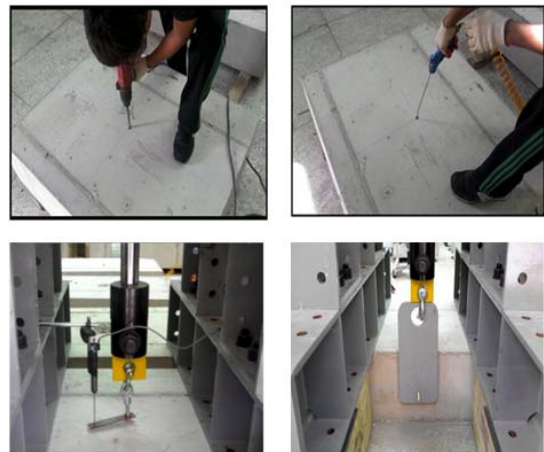

Fig. 4 Test Setup for Post-Installed Anchor Systems

B. Test Specimen

In this paper, the M10, M12 set anchor thread were selected as they were the most generally used thread from a field survey. Specifications of each anchor shown in Fig. 5 include length 200mm diameter 9.45mm (M10) and 12.7mm (M12), length 150mm, diameter 9.45mm (M10) and 12.7mm (M12). Specimens as in Fig. 6 plain concrete, which did not crack (900mm×1100mm×300mm) by subjecting the strength 24MPa experiments, were conducted.

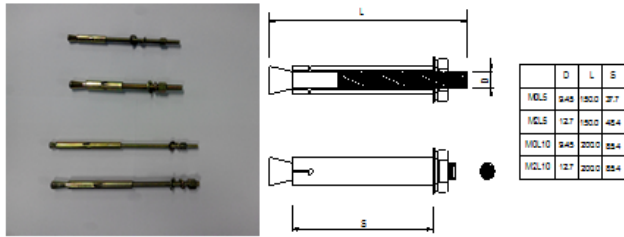

Fig. 5 Set Anchor Types



Fig. 6 Test Specimens of Plain Concrete Systems

C. Test Engineering Demand Parameters

As described in Table I, in order to identify the performance of anchor systems, set anchors were performed by various torque ratios, embedment depths, and diameters of anchor systems. Especially, torque represents the turning force that was required for tightening a nut during and after anchor installation. Therefore, torque variables were critical parameter, in order to understand the changes in the behavior of the anchors. In this study, torque setting variables were conducted at three different levels from 30% to 70% of total 100% torque force at an interval of 20 percent shown in Table II.

TABLE I
TEST SPECIMENS AND PARAMETERS

Specimen	Torque	Embedment Depth (mm)	Anchor diameter	Test number
S3M0L5	30%	50	M10	×3
S5M0L5	50%	50	M10	×3
S7M0L5	70%	50	M10	×3
S3M0L10	30%	100	M10	×3
S5M0L10	50%	100	M10	×3
S7M0L10	70%	100	M10	×3
S3M2L5	30%	50	M12	×3
S5M2L5	50%	50	M12	×3
S7M2L5	70%	50	M12	×3
S3M2L10	30%	100	M12	×3

TABLE II
TORQUE PARAMETERS

Embedment Depth (mm)	Anchor diameter	100% (kN)	70% (kN)	50% (kN)	30% (kN)
50	M10	60.7	42.5	31.4	18.2
100	M10	58.1	40.7	29.1	17.4
50	M12	73.2	51.2	36.6	22.0
100	M12	129.0	90.3	64.5	38.7

IV. NUMERICAL ANALYSIS

A. Material Nonlinearity: Concrete System

In order of capturing damage mechanism for concrete structural system, the Concrete Damaged Plasticity Model was selected as a material nonlinear model applied to the solid element of concrete, because this model shows nonlinear tension softening and complexities of compressions failure. This model is a damage-plasticity constitutive model, and was first proposed by Lubliner et al (1989) and improved by Lee and Fenves (1998) (see Fig. 7)[3], [16].

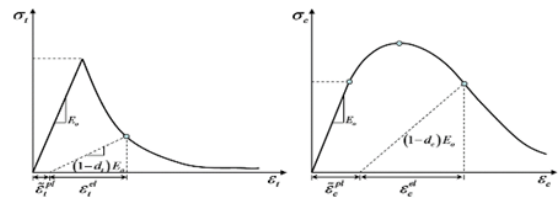

Fig. 7 Concrete Material Nonlinear Model

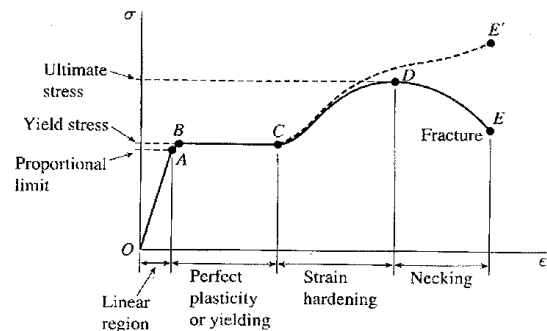

Fig. 8 Steel Material Nonlinear Model

B. Finite Element (EF) Model

To characterize the pullout behavior of concrete and the performance of the post-installed anchor system, generate nonlinear finite element model of the anchor system was necessary to incorporate in the nonlinear finite element model of the plane concrete structural system. Numerical modeling of the two different structural systems was performed in ABAQUS platform. The plane concrete model was discretized using 3D solid element, anticipated to represent nonlinear tension softening and compressive strength, 24MPa. The 3D anchor system model was also targeted on the design with tensile strength of 500MPa. In both models, the anchors and concretes were incorporated with insertion depth 50mm and 100mm, as shown in Fig. 9. Furthermore, to reproduce the performance associated to the experimental test and improve the accuracy for the FE models, the surface between concrete and anchor system was designed for detailed FE models with contact elements using soft contact theory. Further material properties were described in Table III.

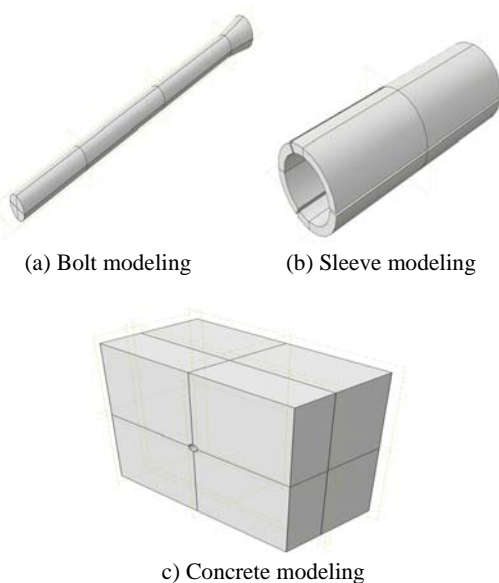

Fig. 9 3D Finite Element Model of Structural System and Anchor System

TABLE III
 MATERIAL PROPERTIES: CONCRETE AND ANCHOR STEEL

	Young's Modulus	Poisson's ratio
Concrete	23025 MPa	0.25
Steel	200000 MPa	0.30

V. ANALYSIS OF EXPERIMENTAL TEST

A. Result: Pull-out Test

Force and the displacement static characteristics were evaluated according to three pull-out tests of the system (see Table IV). Each torque ratio of this study was set based on the embedment depths (50mm and 100mm, respectively). The load values indicated maximum load capacities before failure of the systems and the displacements represented the values corresponding to the maximum load capacities. As shown in Fig. 10, the maximum load capacity values for SnM0L5 and SnM2L10 anchor systems were very close regardless of torque ratio. On the other hand, SnM2L5 anchor system showed the highest load capacity at 70% of the torque ratio and the lowest value at 50% of the torque ratio. The maximum load capacity significantly increased with increasing embedment depth in the anchor system. In addition, as mentioned in section II.B, a pull-out slip failure was observed in this test (see Fig. 12), because the anchor was set without any bonding adhesive except friction between anchor and concrete.

B. Result: Shear Test

Next, we present another structural failure mechanism, i.e. the experimental test based on shear tests. The purpose of this test was to evaluate the shear performance and to compare a behavior with pull-out tests. The maximum load capacities and displacements corresponding to the maximum loads were given

in Table V. Furthermore, Fig. 11 compared the maximum load capacities corresponding to the torque ratios with embedment depths for tow different anchor types. The maximum load capacity for each case system was also very close regardless of torque ratio, which was similar to some of pull-out test results. For example, the maximum loads for both anchor systems increased about 15 percent with increased depths. It was observed that the failure mode was not occurred in concrete but in anchor, in the case of larger anchor with installed depth. The highest load capacity of the shear test was 5.678 ton at 70 % torque ratio in M2L10 anchor type, whereas the values of the pull-out test was 9.437 ton at 30% torque ratio in the same anchor system.

TABLE IV
 SET ANCHOR LOAD-DISPLACEMENT DATA: BASED ON PULL-OUT TESTS

Specimen	Displacement (mm)	Load (ton)
S3M0L5	6.441	2.863
S5M0L5	5.371	2.853
S7M0L5	4.201	2.891
S3M0L10	10.230	4.427
S5M0L10	7.585	4.387
S7M0L10	10.066	3.605
S3M2L5	15.032	2.543
S5M2L5	30.088	1.163
S7M2L5	8.893	3.663
S3M2L10	18.643	9.437
S5M2L10	25.085	8.977
S7M2L10	24.213	9.093

TABLE V
 SET ANCHOR LOAD-DISPLACEMENT DATA: BASED ON SHEAR TESTS

Specimen	Displacement (mm)	Load (ton)
S3M0L5	27.319	3.267
S5M0L5	18.713	3.357
S7M0L5	22.786	3.783
S3M0L10	19.999	3.841
S5M0L10	18.527	3.833
S7M0L10	18.461	3.895
S3M2L5	34.922	5.278
S5M2L5	39.123	4.822
S7M2L5	35.923	4.921
S3M2L10	20.933	5.624
S5M2L10	21.554	5.621
S7M2L10	46.023	5.678

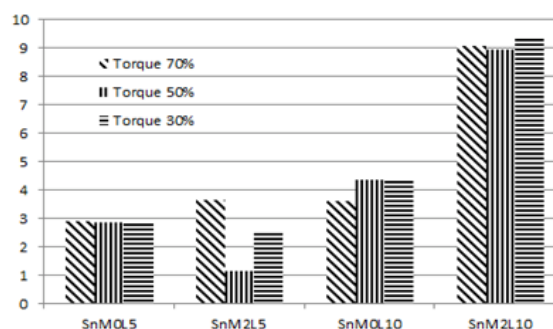

Fig. 10 Anchor Capacity Characteristics for Pull-out Tests

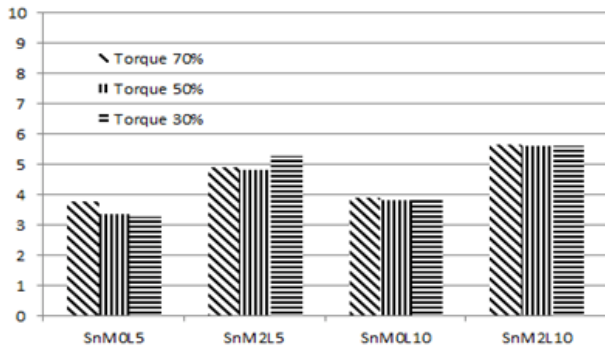

Fig. 11 Anchor Capacity Characteristics for Shear Tests

VI. VERIFICATION OF FE MODEL FOR THE ANCHOR SYSTEMS

In order to verify the 3D nonlinear FE model, it was necessary to compare the results analyzed by ABAQUS and the results based on the experimental tests. Before comparison of the model, Fig. 12 showed the stress distributions of the post-installed anchor system and plain concrete structural system. The stress concentrations were observed at the contact surface of the anchor and the concrete. Fig. 13 compared the load-displacement relationships of the nonlinear FE model using contact elements with those of experimental tests. As shown in the figure, the load-displacement curves based on the FE model were extremely matched well till the failure points to the load-displacement relationships specified by the experimental tests. Differences in maximum loads between two results were less than 6 percent. Furthermore, in FE analysis, the peak loads decreased as the install depth increased. It was mainly due to the modeling of sleeve in anchor system, which assumed soft-contact.

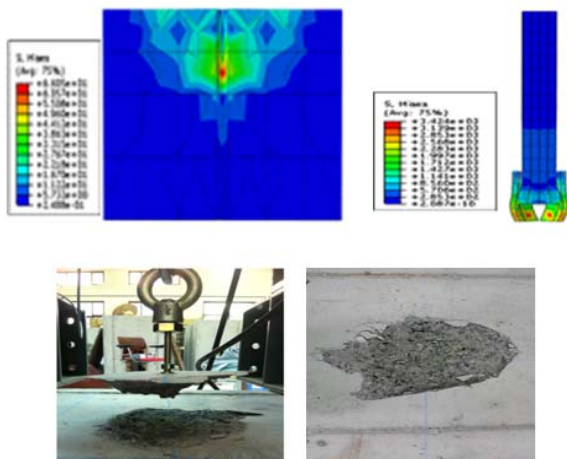

Fig. 12 Stress Distribution of the Systems Using FE Model and Concrete Failure Mode

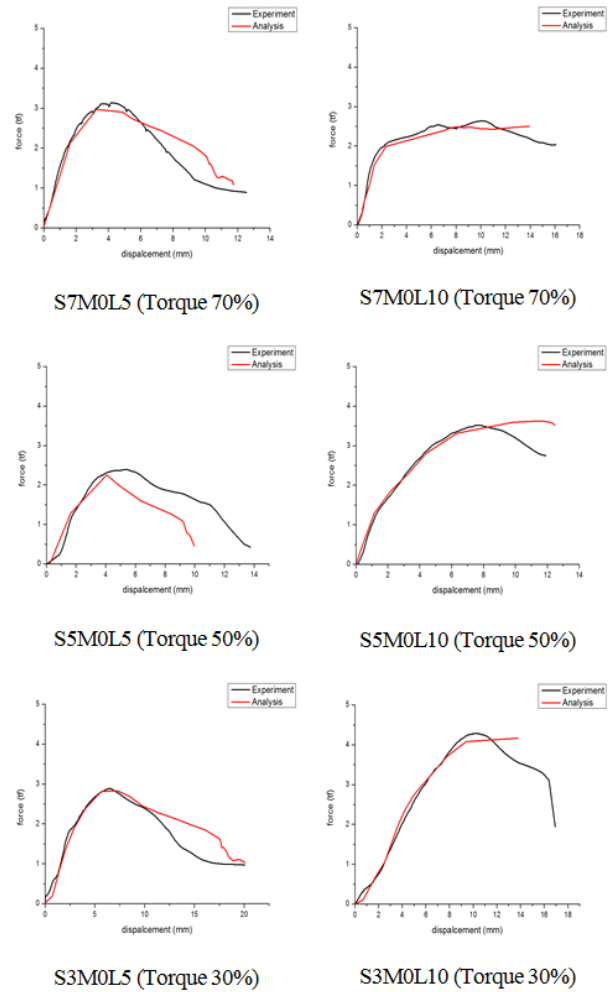

Fig. 13 Verifications of the Finite Element Model on the Experimental Results

VII. CONCLUSION

In this study, pull-out and shear tests of post-installed anchor systems drilled in plain concrete structural system were conducted in order to understand its performance under static loading conditions. The pullout and shear behaviors of the anchor systems were also numerically analyzed by ABAQUS. The conclusions of this paper are as followings:

- 1) The maximum load capacity increased as the diameter and install depth of anchor system became larger, as shown from the pullout and shear experiments for post-installed anchor. A frictional resistance increased by the adhesive area of anchor in concrete. However, the behavior of SnM2L5 was different from others, since the anchor was set without any bonding adhesive. Anchor had larger diameter with smaller install depth, therefore bonding adhesive was not applicable to anchor set. In the pullout test, the peak load with high torque was smaller than that of low torque. Therefore, the increasing of the torque was not quite economical. On the other hand, the torque did not influence the maximum shear loads.
- 2) The failure behaviors of anchor depended on bonding

adhesive between anchor and concrete. If the bonding adhesive was greater due to install depth or torque, steel failures or concrete cone failures occurred. If the bonding adhesive was smaller, splitting or pull-out failure modes were occurred.

- 3) In the pullout test, behaviors of concrete and post-installed anchor were numerically analyzed with finite element model. The surface of concrete and anchor was modeled using soft contact theory. The contact parameters were adjusted using experimental results. Using contact element for the anchor systems accounted for a soft contact, it is worth to propose the model which was quite well predicting the behavior of anchor system.

Future development for dynamic characteristics is needed to identify the performance of post-installed anchor system subjected to extreme loading conditions such as wind loads and seismic events. In addition, further study for limit state of the load capacity in the anchor systems corresponding to the different torque ratio levels must be achieved.

ACKNOWLEDGMENT

This Work was supported by the National Hazard Mitigation Research Group of Korea (NHMRG) grant funded by the National Emergency Management Agency(NEMA) [No. NEMA-NH-2011-49].

REFERENCES

- [1] ko, J. (2004), "Shear Strength of Set Anchors Installed in Plain Concrete," Dongguk University Graduate school: Architectural Engineering 2004. 1
- [2] Kwon, M. and Jang, J. (2004), "Nonlinear Finite Element Analysis of Reinforced Concrete Columns," *Journal of KCI*, vol. 16, no.3, pp.397-406. 2
- [3] Kwon, M. and Jo, C. (2003), "A Concrete Model for Analysis of Concrete Structure with Confinement," *Journal of KCI*, vol. 15, No.3, pp 433-442 3
- [4] Kim, S. (2004), "Strenght evaluation of expansion anchors installed in plain concrete," Dongguk University Graduate school: Architectural Engineering 2004. 2 4
- [5] Kim, Y. (2002), "Performance test of Chemical Anchor Bolts for Concrete Repair," *Journal of the Korean Society of Safety*, vol. 17 No.2 [2002] 85-91 5
- [6] Son, J. (2002), "Fracture analysis of concrete anchor systems subjected to shear loads," Yonsei University Graduate school: Civil Engineering 2002. 2 7
- [7] Jin, S. (2011), "Tension and shear strength valuation of large size concrete anchor bolt," Pusan University Graduate school: Civil and Environmental Engineering, Civil Engineering 2011. 2 9
- [8] ACI Committee 349 (1978), "Code Requirements for Nuclear Safety Related Concrete Structures," *ACI Journal*, 75, pp. 329-347 12
- [9] M. Young, *The Technical Writers Handbook*. Mill Valley, CA: University Science, 1989.
- [10] ACI Committe 446 (1995), "Finite Element Analysis of Fracture in Concrete Structures," Report of Subcommittee 3, American Concrete Institute, Detroit
- [11] ACI Committe 349 (2000), "Code Requirement for Nuclear Safety Related Concrete Structures and Commentary," *ACI 349R-97*, pp. 349R1-349R31
- [12] ASM (1991), *ASM Handbook: Irons, Steels, and High Performance Alloys*, ASM International Barzegar, F. and Maddipudi, S. (1997), "Three-Dimensional Modeling of Concrete Structures II: Reinforced Concrete," *Journal of Structural Engineering*, Vol. 123, No.10
- [13] Fuchs, W., Eligehausen, R. and Breen, J. E. (1995), "Concrete Capacity Design (CCD) Approach for Fasteign to Concrete," *ACI Structural Journal*, vol. 92, pp. 73-94
- [14] Hillerborg, A., Modeer, M., and Petersson, P. E. (1976), "Analysis of Crack Formation and Crack Growth in Concrete by means of Fracture Mechanics and Finite Element," *Cement and Concrete Research*, 6, pp. 773-782
- [15] Kwon, M., Park, M., and See, S. (2000), "A 3D Concrete Constitutive Model for Cyclic Analysis of Concrete Structures," *KSCE Journal of Civil Engineering*, vol 4(4), pp.165-173
- [16] Kwon, M. and Spacone, E. (1999), "A Hypoelastic model for Cyclic Response of Concrete Structures," *ASC*
- [17] *Mechanics of Materials 6th Edition*, James M. Gere, chapter 1