

Self-Excited Vibration in Hydraulic Ball Check Valve

L. Grinis, V. Haslavsky, U. Tzadka

Abstract—This paper describes an experimental, theoretical model and numerical study of concentrated vortex flow past a sphere in a hydraulic check valve. The phenomenon of the rotation of the ball around the axis of the device through which liquid flows has been found. That is, due to the rotation of the sphere in the check valve vibration is caused. We observe the rotation of the sphere around the longitudinal axis of the check valve. This rotation is induced by a vortex shedding from the sphere. We will discuss computational simulation and experimental investigations of this strong sphere rotation. The frequency of the sphere vibration and interaction with the check valve wall has been measured as a function of the wide range Reynolds Number. The validity of the computational simulation and of the assumptions on which it is based has been proved experimentally. This study demonstrates the possibility to control the vibrations in a hydraulic system and proves to be very effective suppression of the self-excited vibration.

Keywords—Check-valve, vibration, vortex shedding

I. INTRODUCTION

INTERNAL flows in hydraulic system have been studied extensively lately because of their practical applications. For example, ball checks valve and other device in hydraulic systems. It is known [1]-[3] that the process of fluid flow around a bluff body (sphere, cylinder) is accompanied by a periodic vortex trail (vortex street of Karman), which induces vibrations and that the resulting forces act on the bluff body in a direction transverse to that of the flow. The growth and movement of these vortices creates a fluctuating lift and drag force on the body [3],[4]. It is known that flow in hydraulic device is turbulence and it set up chaotic vibration [2]-[4]. There is a growing body of evidence that an understanding of exploitation of vibration may be desirable or beneficial for the operation of some hydro-mechanical systems. Understanding and subsequent exploitation or avoidance of fluid turbulence is one of the major problems in many fields.

We reveal the phenomenon of the vibration and rotation of the sphere around the axis of the inner surfaces of the check valve in the flow. This phenomenon was investigated by experimental device and by computational simulation.

Applications of computational fluid dynamics (CFD) to the industry continue to grow as this advanced technology takes advantage of the increasing speed of computers. In the last two decades, different areas of flow modeling including grid generation techniques, solution algorithms, turbulence modeling, and computer hardware capabilities have witnessed tremendous development. In view of these developments, computational fluid dynamics can offer a cost-effective solution to many engineering problems. Various researchers used turbulence modeling to simulate flow around axisymmetric bodies.

In this study we use Fluent (fluid dynamics computer simulation software) to model the flow around a sphere in check valve, when the flow is turbulent. Prediction of flows that exhibit massive separation remains one of the principal challenges of CFD. The main interest of the present study is to calculate the turbulent flow over a sphere at high Reynolds numbers.

The nature of the flow around a sphere in valve changes as the Reynolds number of the flow increases, according to Constantinescu [8],[9].

The aims of this study were: the experimental investigation of the stability and instability of the vibration of the sphere in fluid flow inside a check valve; derivation of a simplified analytical expression for the stability of the vibration motion of the sphere rotating in a valve under conditions of fluid flow; validation of the mathematical model and computational simulation versus experimental results; illustration of the possibility to exploit this phenomenon.

II. EXPERIMENTAL APPARATUS

A schematic description of the experimental setup is presented in Fig. 1(a). The system consists of the following components: storage tank 1, centrifugal pump 2, throttle valve 3, manometers 5 and 8, flow meter 4, ball check valve 6, stroboscope tachometer 7, spectrum analyzer vibration meter 9. The fluid (in our case is water) is circulated from tank 1 through ball check valve 6 by centrifugal pump 2.

The flow rate was controlled by throttle valve 3 and measured by flow meter 4.

L. Grinis: Sami Shamoon College of Engineering, Basel/Bealick Sts. Beer Sheva, 84100 Israel, e-mail address: grinis@sce.ac.il

V. Haslavsky: Sami Shamoon College of Engineering, Basel/Bealick Sts. Beer Sheva, 84100 Israel, e-mail address: vit1205@yahoo.com

U. Tzadka: Sami Shamoon College of Engineering, Basel/Bealick Sts. Beer Sheva, 84100 Israel, e-mail address: uriz@sce.ac.il

The fluid passes through the gap between the ball's surface, which is replace, and the wall of the valve.

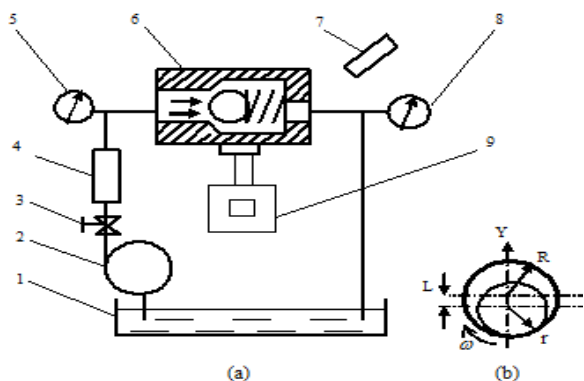

Fig. 1 Experimental setup

The frequency of the vibration was measured by FFT spectrum analyzer vibration meter (type SR 760) and using acceleration sensor (Bruel & Kjaer type 4375V). The rotation speed of the ball was also measured by stroboscope tachometer, when we used valve's body made of transparent material. The size of ball in combination with inner valve's diameter was examined for certain value of the flow rate (in the following ranges: ball diameter 0.012 m; inner diameter of the valve 0.015 m, and flow rate up to $1 \times 10^{-3} \text{ m}^3/\text{s}$).

III. MATHEMATICAL MODEL

A schematic description of the device used in this study is given in Fig. 1(b). The device, which is essentially spherical in shape, is introduced into a valve through which liquid is flowing. From experimental analysis of fluid flow around a sphere [5], it is known that vortices form in the wake of the sphere and subsequently break away from it in a periodic process. This phenomenon is called a "Karman vortex street". The vortex shedding can produce self-excited oscillations of the ball. This oscillation is characterized by the frequency which depends on the flow conditions. Assuming that the distance between the ball and the valve surface is constant, we can regard this ball as a pendulum or rotor of length L and mass m whose point of support is caused to vibrate with amplitude A_0 along the Y axis of the valve as following equation:

$$y = A_0 \sin \omega t \quad (1)$$

Such system can be made clear by means of a classic example of a pendulum with a vibrating axis [6]. The movement of the ball can be expressed by the following differential equation:

$$mgL \cos \psi - k \dot{\psi} - mL A_0 \omega^2 \cos \psi \sin \omega t = m \rho^2 \ddot{\psi} \quad (2)$$

where $k \dot{\psi}$ represents the damping, present in all physical systems.

Assuming that

$$\psi = \omega t + \alpha \quad (3)$$

where α is a slowly varying function of time, and substituting (3) into (2) we obtain differential equation of motion of the system.

The differential equation have been studied by Panovko and Blekhan[6],[7]. The relation of the sphere in synchronous regime proceeds according to the equation:

$$\frac{2k}{mL A_0 \omega} < 1, \quad (4)$$

Under steady state conditions, the ball will vibrate and also rotate around the central axis of the valve at an angular velocity which is given by the following equation:

$$\omega = \frac{\nu \cdot Re}{2r(R+r) \left[\frac{\pi}{8} (1 + \cos \frac{\pi}{4}) \frac{C_f}{C_v} + \frac{1}{6\sqrt{2}} \frac{C_p}{C_v} \right]} \quad (5)$$

Where ν - kinematic viscosity of the water, Re - Reynolds number, C_f , C_p , C_v - hydrodynamic friction coefficient. This equation was obtained with used solution based on forces and driving moments of balance that act in this system. Substituting (5) into (4), we obtain the condition for stable vibration and also rotation of the ball as a function of the system parameters:

$$\frac{4kr(R+r) \left[\frac{\pi}{8} (1 + \cos \frac{\pi}{4}) \frac{C_f}{C_v} + \frac{1}{6\sqrt{2}} \frac{C_p}{C_v} \right]}{m(R-r) A_0 \nu Re} < 1 \quad (6)$$

Using the above condition for stability of rotation of the ball in a valve with fluid flow, it is possible to determine the influence of the system parameters on the ball's rotation and define the conditions limiting its rotational motion.

IV. EXPERIMENTAL RESULTS

The experimental apparatus allows us to explore the sphere and valve's wall interactions for different conditions. The results of the measurement dimensionless frequency vibration of the ball vs. Reynolds number are presented in Fig.2. It can be seen that the frequency of vibration depends to the flow rate. The experiments showed that the frequency of vibration of the ball is directly proportional to the angular velocity of its rotation. The regimes of the stable and unstable vibration of the ball for other conditions of the device were also found. We obtained, that the ball reaches the steady state vibration only at Reynolds number above 11000.

Fig. 2 represents the results of the measurements and numerical calculations. It can be seen that the frequency of vortex shedding is directly proportional to the flow rate (the graph shows the frequency dependence of Reynolds number) in the valve. The experiment results (blue square points) showed that the frequency of the sphere rotation is also directly proportional to the flow rate. It was also found that the sphere reached steady state rotation speed only at Reynolds numbers above 11,000. The linear relationship between sphere rotation and the Reynolds number found experimentally coincided very well with the curve 1 represented by eq.5 and also qualitatively agreement with result of the computational simulation (curve 2).

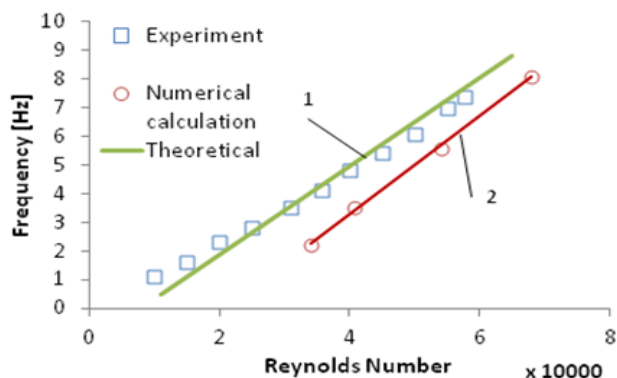

Fig. 2 Vibrations frequency in experiment (blue square points), lift coefficient frequency (C_L) from numerical calculation (curve 2) and theoretical calculation (curve 1) vs. Reynolds number

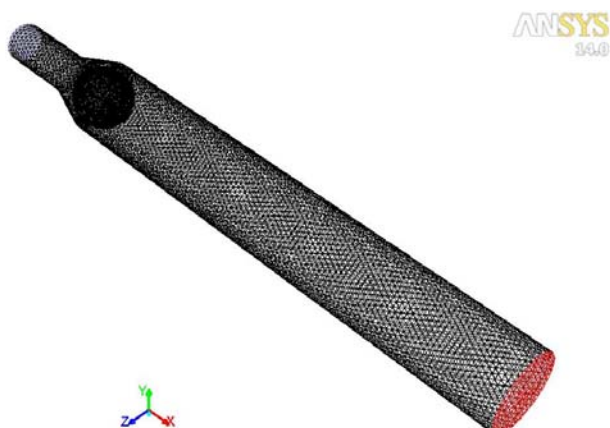

Fig. 3 Numerical calculations mesh

V. SIMULATION OVERVIEW

A computational model of unsteady, periodically separated, high Reynolds number flow in the hydraulic ball check valve is developed using computational fluid dynamic software Fluent 14. The code solves time dependent equations for conservation of mass, momentum using second-order accurate, cell-centered finite volume method on unstructured grids.

The computation domain is divided into 128960 grid elements of edge size ~1 mm with the strong smoothing region around the ball and with the medium smoothing region in the pipe after the ball (i.e. in the ball-wake region).

The simulations include large-eddy simulation (LES) turbulence modeling based on a wall-adapted local eddy-viscosity (WALE) sub-grid-scale model. Due to the high Reynolds number simulations, wall shear stress of the ball is modeled by using the instantaneous logarithmic law of the wall. Since the simulated flow is assumed to be fully turbulent, the turbulence model is active over the entire surface of the ball using the Switch P-V Coupling Scheme (Coupled), Bounded Central Differencing for spatial discretization of the momentum equation and Switch Spatial Discretization Scheme for pressure (PRESTO!). The calculations were running for 10000 time steps with 1e-3 seconds time step size yielding 50 iterations per time step.

The periodicity nature of the flow over the ball is considered to be due to periodical shedding of vortexes. To determine the major vortex-shedding frequency we have used Fast Fourier Transform (FFT) of time-history of the lift coefficient on the ball recorded during simulations (Fig. 6). To observe the shedding of vortexes we present the iso-contours of velocity magnitude (Fig. 4), streamlines in the xy-plane (Fig. 5) and normalized Q-criterion for vortex identification (Fig. 7). According to Jeong and Hussain (1995) [10], Q-method it is the one of the most appropriate method of identifying a vortex in a turbulent flow, where Q is the positive second invariant of the deformation tensor.

VI. CONCLUSIONS

The following results were obtained in this study

The stability and instability of the vibration of the ball in a valve were studied by an experimental method. We received a criterion for rotational stability of the ball and described the main relationships that govern the rotation process;

The model in FLUENT is used to predict the flow over a sphere in the valve for a range of Reynolds number up to 10^4 .

Comparison of the present results with experimental data and empirical correlations showed that the predictions obtained by CFD software successfully reproduced most of the flow features associated with the vortex shedding.

This study demonstrates the possibility to control the vibration in a hydraulic system.

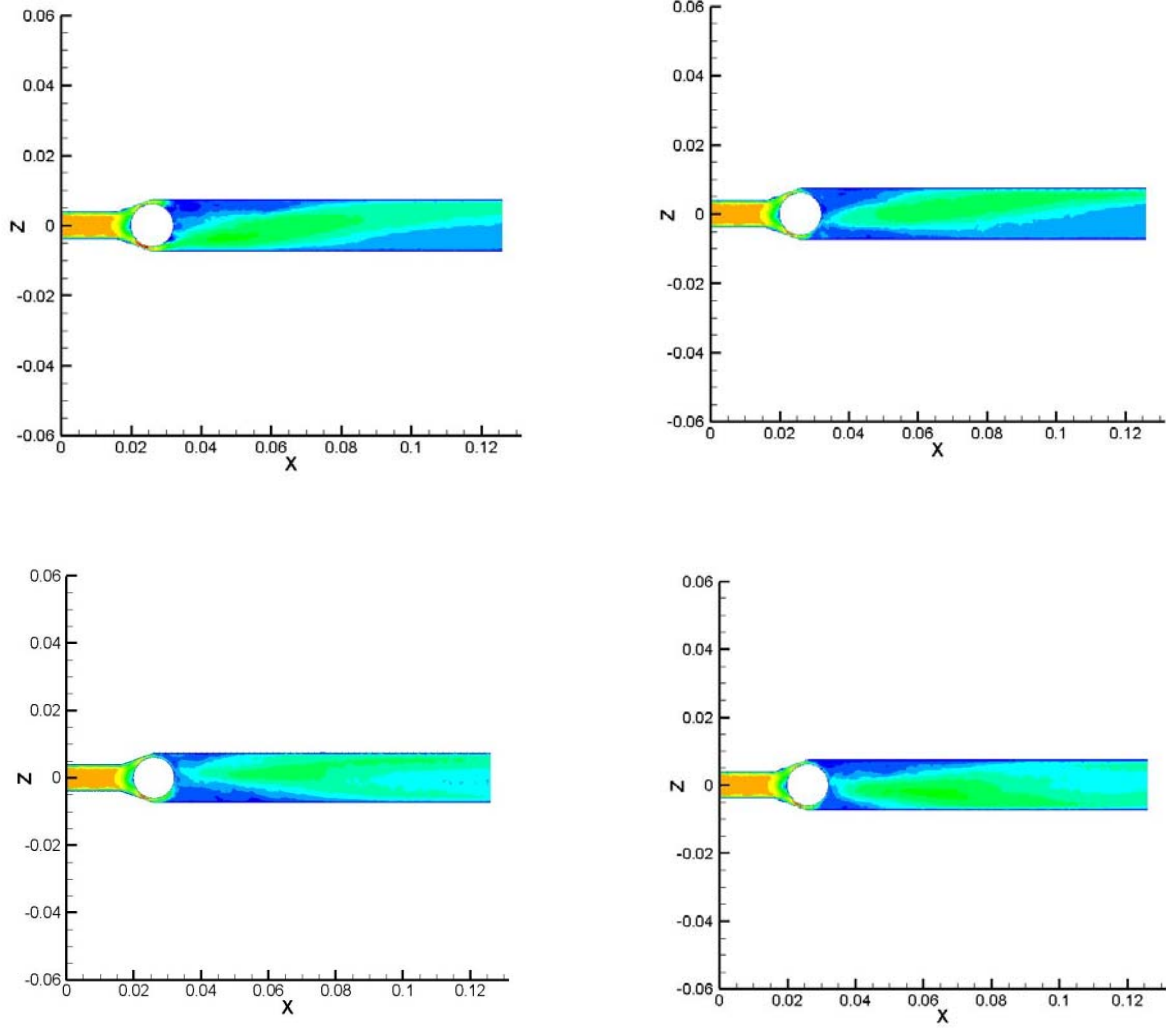
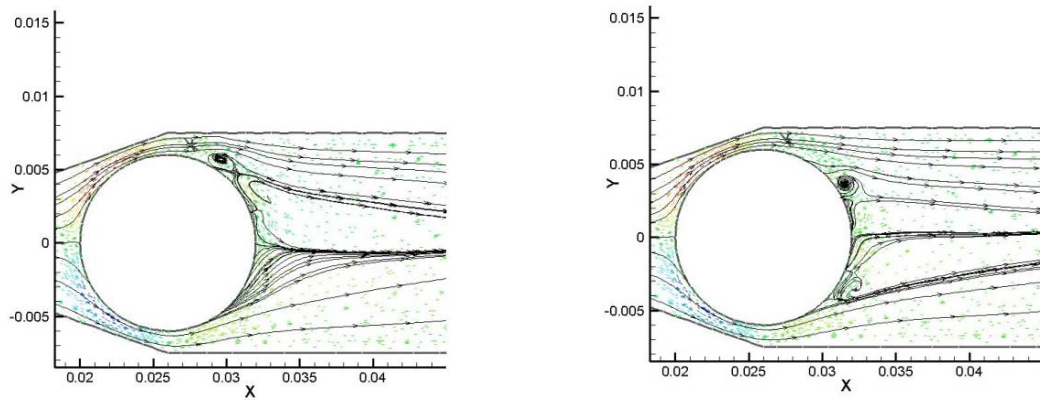

Fig. 4 Mid-section (X-Z plane) velocity field during one period of oscillation



t=0.1 sec

t=0.15 sec

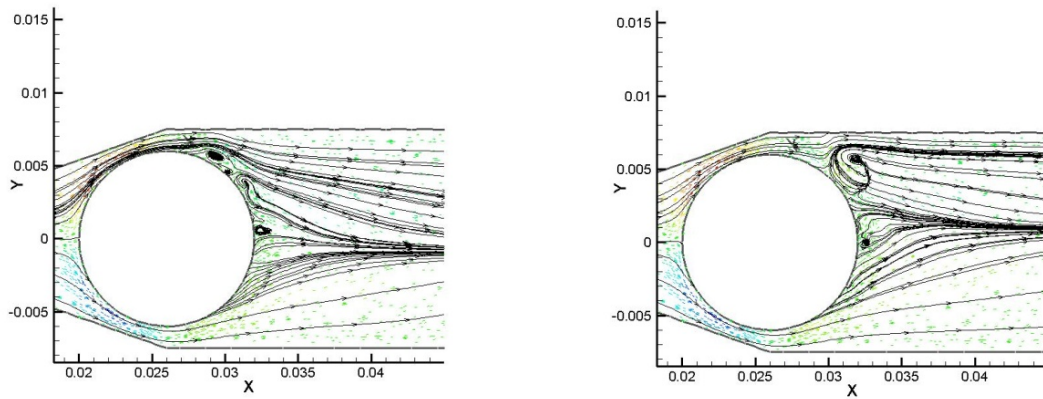

Fig. 5 Mid-section (X-Y plane) streamlines during one period of oscillation

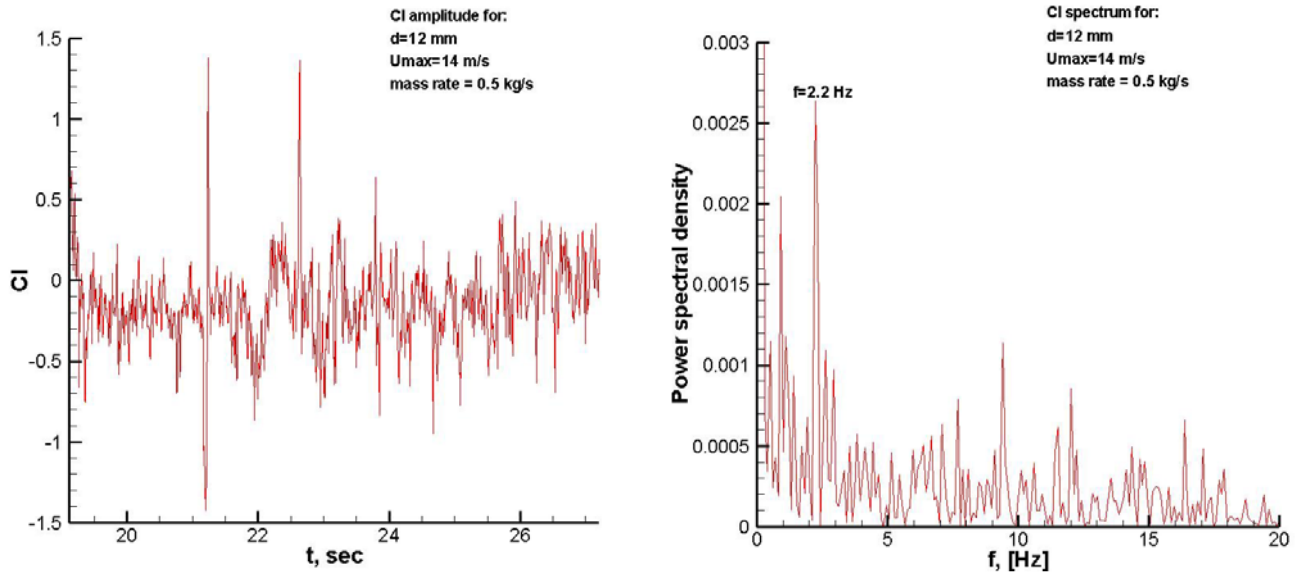

Fig. 6 Time series (left) and Power spectrum (right) of C_L for mass rate flow of 0.5 kg/sec.

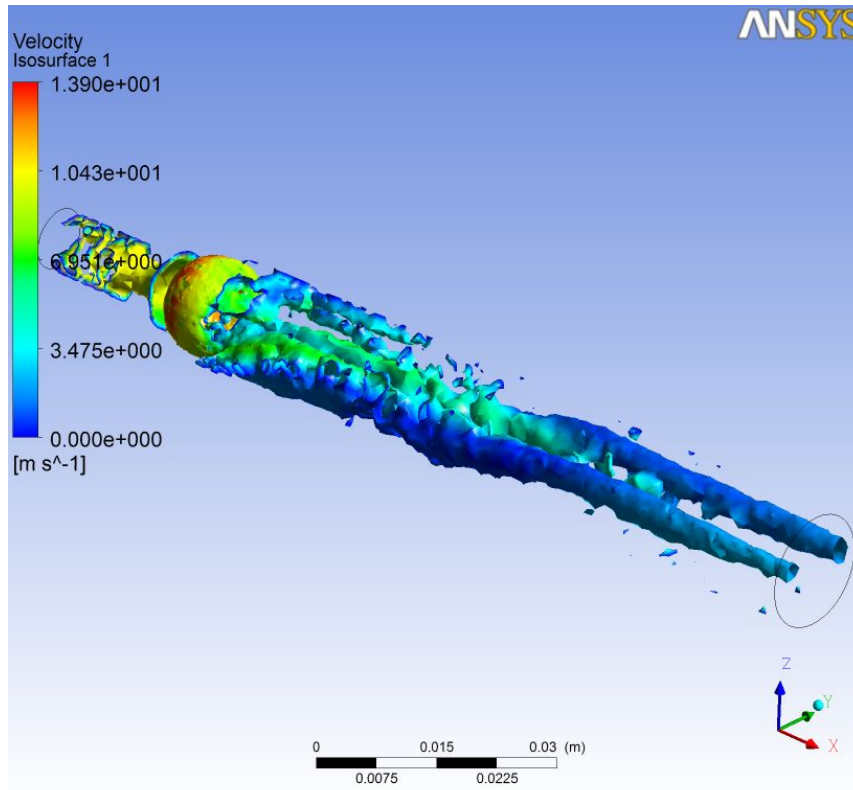

Fig. 7 Q-criterion for vortex identification

REFERENCES

- [1] Moon Francis. C., Chaotic Vibrations.(John Wiley & Sons, 1987)
- [2] Fradkov A. L., Pogromsky A. Yu., An Introduction to Control of Oscillations and Chaos. (World Scientific Series On Nonlinear Science, 1998)
- [3] Blevins, R.D., Flow – Induced Vibration. (Kreiger, Malibar, Fla., 1994)
- [4] Cyril M. Harris., Shock and Vibration Handbook. (McGraw-Hill 1995)
- [5] Grinis L., Korin E., “Hydrodynamic method for cleaning inner surfaces of pipes” Chem. Eng. Technol. 20, N4, 277-281(1997)
- [6] Panovko Y. G., Gubanov I.I., Stability and Vibration of Elastic Systems. (Moscow, 1987)
- [7] Blekhman, I.I. Synchronization in Science and Technology (ASME Press, New York, 1988)
- [8] Constantinescu, G., Chapelet, M, and Squires, K (2003). “Turbulence Modeling Applied to Flow over a Sphere”.AIAA Journal, Vol. 41, No. 9, pp.1733-1742.
- [9] Constantinescu, G, (2004) ” Numerical investigations of flow over a sphere in the subcritical and supercritical regimes” J. Physics of Fluids, Vol. 16, No., 5, pp. 1449-1466
- [10] Jeong, J and Hussain, F., “On the identification of a vortex”, J. Fluid. Mech., 285, 69-94 (1995).