

Experience-based Learning Program for Electronic Circuit Design

Koyu Chinen, Haruka Mikamori

Abstract—A new multi-step comprehensive experience-based learning program was developed and carried out so that the students understood about what was the principle of the circuit function and how the designed circuit was used in actual advanced applications.

Keywords—Electronic circuit education, Experience based learning, Comprehensive education,

I. INTRODUCTION

IN the past electronic circuit education, students were not easy to understand how the circuits that they designed were used in the current equipments. It is important for the students to know that the electronic circuit design realizes actually advanced application systems in their surroundings. In addition to it, it is also important to learn electronics circuit theory in conjunction with practical experiments [1],[2]. Experience-based learning program is effective for deep understanding of principle of the circuits. This program is composed with comprehensive experimental fabrications from a simple circuit to functional module.

The use of many different types of circuits in the program have to be avoided for the subject of the samples of the circuit fabrication, because it costs up and defocuses the subject matter. The amplifier was selected as main object of the circuit design in this program, since the amplifier had been applied as a key device for many different types of applications.

Furthermore, in this multi-step program, students became familiar to learn more functional design tools, deep structure of high frequency devices, precise device parameters, and advanced measurement equipments.

II. LOW FREQUENCY CIRCUITRY DESIGN

As the 1st step learning program a universal circuit board was used. There is a commercially available circuitry board for training of the design of general circuitries, such as amplifier,

K.Chinen is with Okinawa National College of Technology, 905 Henoko, Okinawa, JAPAN (corresponding author to provide phone: +81-980-55-4143; fax: +81-980-55-4012; e-mail: k.chinen@okinawa-ct.ac.jp).

H. Mikamori is a student of Advanced Course in Okinawa National College of Technology, 905 Henoko, Okinawa, JAPAN (e-mail: ac104608@edu.okinawa-ct.ac.jp).

oscillator, and modulator [3]. This board is useful for learning many different types of basic circuitries. On this board, for example, 400 analog and digital circuit designs are available. And this board has a multi-volts battery, Light Emitting Diode (LED), speaker, switch, antennas, coil inductor, and a 4-bits Micro Processor Unit (MPU). In the wire connection of those parts, a long length of wire is needed since the positions of the parts are fixed, and only the length of the wires is flexible. Therefore, the frequency of the circuitry is limited to about 100kHz. And it was difficult to learn about the noise in the circuitry. Therefore this type of the multi-purpose learning board was useful for the 1st to 3rd grade students. They used one training board for each. The number of the students who learn at this level of the program was about 40.

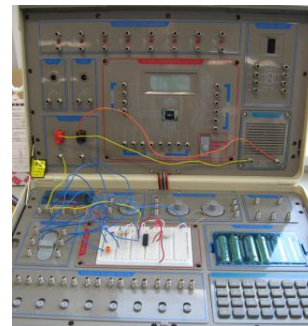

Fig.1 A commercially available general purpose training-board for low frequency circuitry design learning.

III. SPECIFIC AMPLIFIER DESIGN

At the 2nd step learning program, a specific circuitry board was useful to learn DC bias circuit, amplifier gain, frequency response, and negative feedback circuit of the amplifier. This board was made with a Printed Circuit Board (PCB) of Epoxy. The main Radio Frequency (RF) signal line was printed on the circuit board. The students inserted the components of resistors, capacitors, and transistors in the PCB. An assembled PCB is shown in Fig.2(a). They made one amplifier for each. In the schematic circuit design work the students were able to use a

SPICE base simulator, such as Micro-CAP. An example of the schematic design is shown in Fig.2(b).

Since this board had a stable frequency characteristic, the students were able to use a functional signal generator and an oscilloscope to measure the AC response of the amplifier for several hundred kHz or over. A PC adaptable oscilloscope was used to edit the measured data and figure for making a report. About 10 measurement set-ups were used for one class of 40 students.

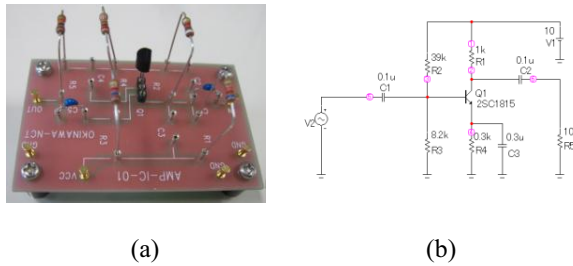

Fig.2 (a) Specific design board for learning of several hundred kHz amplifiers. (b) A schematic design carried by using a SPICE simulator.

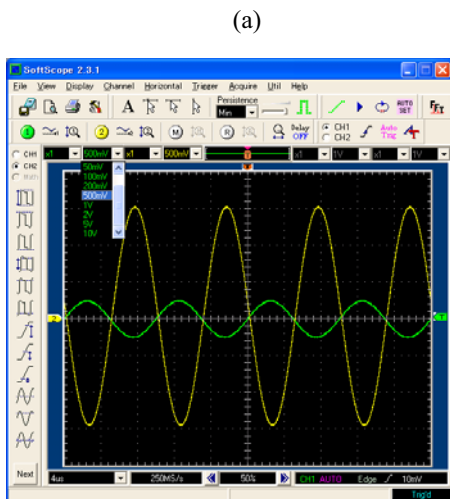
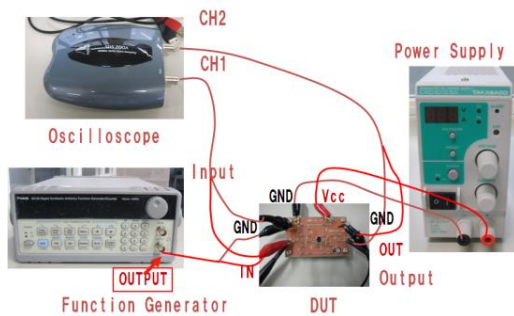

Fig.3 (a) Amplifier characteristic measurement set-up using a function generator and PC based oscilloscope. (b) Measurement result of input and output signal waveform.

IV. HIGH FREQUENCY CIRCUITRY DESIGN

At the 3rd step learning program, to learn more precise design of amplifier at GHz frequency band, it was necessary to use a Micro-stripe Line (MSL) on the PCB and surface mount resistors, inductors, capacitors, and transistors for the passive components. In case of the design of a low noise amplifier, High Electron Mobility Transistor (HEMT) had to be used for active components.

For the Radio Frequency (RF) amplifier design, the students learned more sophisticated design tools, such as Microwave Office (AWR) and Advance Design System (ADS, Agilent) [4],[5]. To start the design of the amplifier, the students had to look for Scattering (S)-parameters from the manufacturers of the components to be used in their amplifiers. By doing this, the students learned how the actual components had different characteristics from the ideal ones which they learned in the text book. Also they learned that the characteristics of the components were different among the manufacturers. Therefore it was important to find the proper manufactures for the components that satisfied the performance of the amplifier, in addition to the proper circuit schematic. They also learned about the material of the substrate and mechanical size of the Micro Strip Line (MSL), since those parameters affected the frequency characteristic of the amplifier. An example of the schematic design of the amplifier is shown in Fig.4.

The students learned how the mounting technique was important when soldering a small size of 1806-type component on the PCB, since the soldering skill affected its electrical performance. An example of the surface mounted amplifier on the PCB is shown in Fig.5

After the precise design work, the students were able to learn how to measure the noise figure and S parameters. They used advanced measurement equipments such as spectrum analyzer, network analyzer, and sampling oscilloscope, by using RF coaxial cables and Small Miniature Assembly (SMA) connectors. This level of precise amplifier design learning had been carried out for the 4th to 5th grade students. The number of the students was about 10.

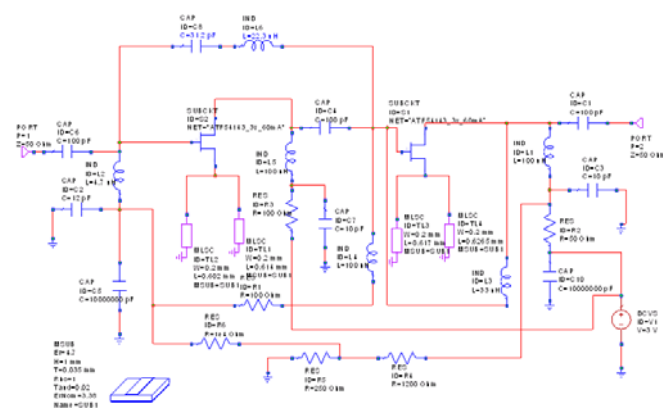

Fig.4 An example of schematic design of amplifier. Suppliers information for S-parameters, material data of PCB, and MSL data were taken into account.

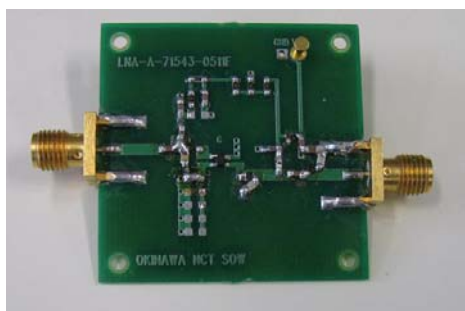
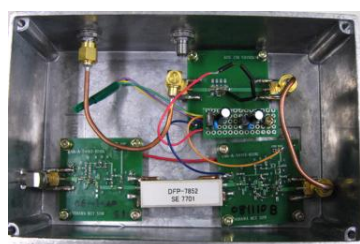

Fig.5 Surface mount PCB for learning high frequency characteristics.

V. MODULE DESIGN

At the final step learning program, the students learned more complex circuit design for actual applications, such as wireless and optical communications. In this advanced design work, the students assembled a module which included multi-stage amplifiers, band pass filter, bias TEE, and DC-DC converter. With this module the students learned how the integrated components worked in the communication system. For example, this kind of modules were able to be applied for Low Noise Amplifier (LNA) of the satellite receiver. An example of the LNA module and its block diagram is shown in Fig.6(a) and (b), respectively. Each component was connected in the module by using RF cables. The students learned how the electromagnetic radiation in the module affected the noise figure of the LNA, and how electromagnetic shielding was important in the module. In some case, the students knew that the PCB design was insufficient for stable operation, after the cable connection. In this case the design work had to be restarted. The students learned a lot about what was important in the re-design work.



(a)

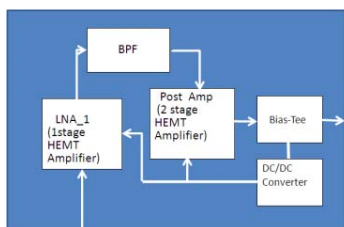

(b)

Fig.6 Sub-system module of LNA; (a) photo of the module inside, and (b) block diagram.

In another example of the module was optical-electrical (O/E) converter and electrical-optical (E/O) converter for high speed optical communication. In the module the amplifier was a key device to modulate the laser diode at a high speed.

An example of the assembled module is shown in Fig.7(a), and its block diagram is shown in Fig.7(b). The students learned how the electrical frequency flatness was important in the amplifier design for the E/O converter.

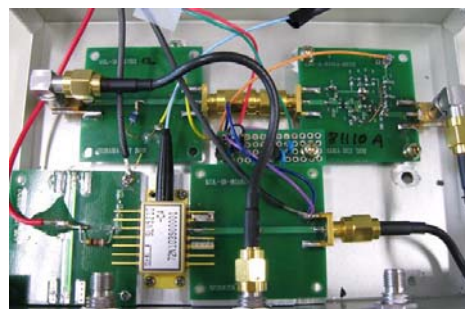

(a)

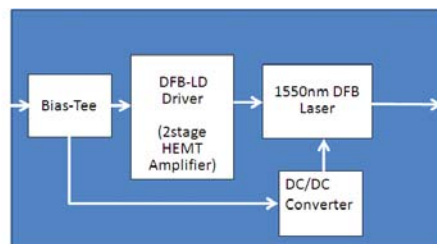

(b)

Fig.7 Sub-system module of O/E; (a) picture of the module inside, and (b) block diagram.

In the final stage, the students were able to install the LNA, E/O, and O/E modules to a weather satellite receiving system, as shown in Fig.8. A satellite signal was received with a parabolic antenna and LNA. The electrical signal was converted by the E/O module to extend the transmission distance, and received at an E/O module and converted to electrical signal.

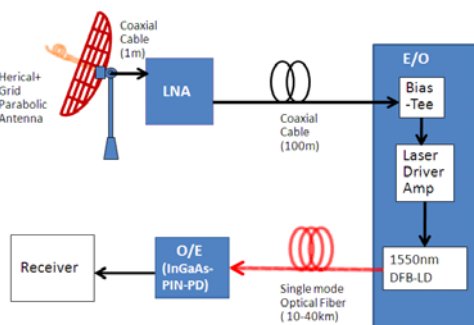

Fig.8 A weather satellite receiving system in which the modules designed by students were installed.

The electrically converted signal was received at the receiver to decode the signal to the picture images.

The system tracked the moving satellites and received the signal from them. Since the NOAA-18 and 19 satellites were sending clear images, the system was able to receive the signal when the receiving system had low noise, high gain, and linear amplifiers [6]. An example of the received image from NOAA 19 is shown in Fig.9. The students learned how the electrical design was important to get useful information. This level of module design learning was carried out for the 5th grade and advanced students. The number of the students was about 5.

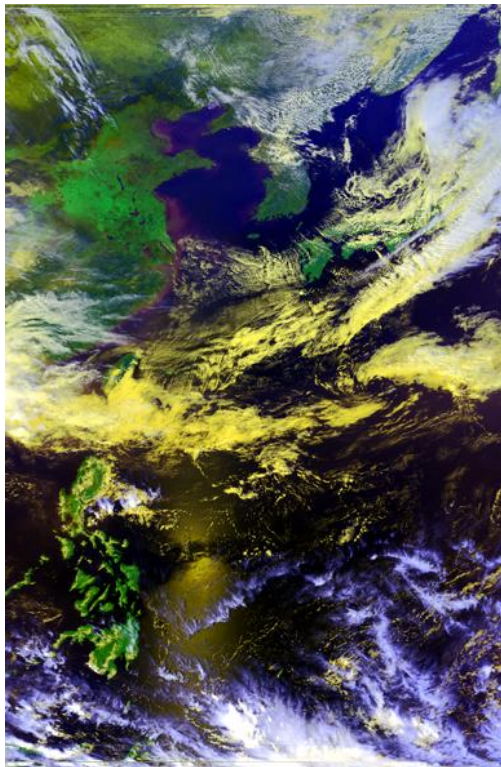

Fig.9 A received image from a weather satellite of NOAA-19.

VI. MULTI-STEP COMPREHENSIVE LEARNING PROGRAM

A multi-step comprehensive experience-based learning program for electronic circuit design education has been carried out. This program consists of four steps of learning grades from the simple circuitry design to advanced sub-system design, as shown in Table 1. The program started at the 3rd grade students and finished at the 5th or advanced course. In the earlier steps, the students learn simple circuitry and basic measurements technique. In the advanced steps, the students learn a complicated design and precise measurements, but also their knowledge expand toward components manufacturer, physical design, tiny parts soldering skill, electromagnetic radiation, precise RF measurements, module assembly, and actual

application. And finally they learn what the electrical circuit realizes.

TABLE I
 A MULTI-STEP COMPREHENSIVE EXPERIENCE-BASED LEARNING PROGRAM FOR ELECTRONIC CIRCUIT DESIGN EDUCATION

Step	Type of Circuit Board	Frequency Band	Design Tools	Equipments	Measurement Items
1st	General purpose training board	1kHz	Non	Non	• Voice • LED • Sounds
2nd	Specific amplifier design board	100KHz	• SPICE • MicorCap	• Oscilloscope • Function generator	• Waveform
3rd	Surface mount PCB	3GHz	• Microwave Office(AWR) • ADS (Agilent)	• Spectrum Analyzer • Network Analyzer	• Gain • NF • Eye diagram • Spectrum
4th	Module	3GHz	• Microwave Office AWR) • ADS (Agilent)	• Bit Error Tester • Vector Signal Generator • Vector Signal Analyzer	• Image • Picture

VII. CONCLUSIONS

In the Okinawa National College of Technology, 4 steps-comprehensive-experience-based learning program for electronic circuit design education was carried out. This is an integrative circuit design education program which realizes that the students learn the circuits operating from low frequency to high frequency and the functions from components to sub-system. By stepping up the circuitry design work, the students learned the design tools, measurements equipments, and precise function. In the final stage the students learned the application of the circuitry.

ACKNOWLEDGEMENTS

This research work has been partially supported by a 2009 research support program of the Foundation for Technology Promotion of Electronic Circuit Board of Japan.

REFERENCES

- [1] Rafael Magdalena, et. al., "A Teaching Laboratory in Analog Electronics: Changes to Address the Bologna Requirements," *IEEE Transactions on Education*, vol. 51, no.4, Nov. 2008, pp.456-460
- [2] Nurul I. Spakar, "Teaching Computer Networking Fundamentals Using Practical Laboratory Exercises," *IEEE Transactions on Education*, vol. 49, no. 2, May 2006, pp.285-291
- [3] <http://www.hktdc.com/em/maxitronixenterpris>, www.catalysts.co.jp/,
- [4] <http://web.awrcorp.com>
- [5] <http://www.home.agilent.com>
- [6] <http://www.oso.noaa.gov/poesstatus/>