

Performance Evaluation of Complex Electrical Bio-impedance from V/I Four-electrode Measurements

Towfeeq Fairouz, Salim Istyaq

Abstract—The passive electrical properties of a tissue depends on the intrinsic constituents and its structure, therefore by measuring the complex electrical impedance of the tissue it might be possible to obtain indicators of the tissue state or physiological activity [1]. Complete bio-impedance information relative to physiology and pathology of a human body and functional states of the body tissue or organs can be extracted by using a technique containing a four-electrode measurement setup. This work presents the estimation measurement setup based on the four-electrode technique. First, the complex impedance is estimated by three different estimation techniques: Fourier, Sine Correlation and Digital De-convolution and then estimation errors for the magnitude, phase, reactance and resistance are calculated and analyzed for different levels of disturbances in the observations. The absolute values of relative errors are plotted and the graphical performance of each technique is compared.

Keywords—Electrical Impedance, Fast Fourier Transform, Additive White Gaussian Noise, Total Least Square, Digital De-Convolution, Sine-Correlation.

I. INTRODUCTION

THE human body is an electrically conducting medium with an anisotropic conductivity distribution determined by the electrical property of numerous biological tissues. The electrical properties, conductivity and permittivity, of a biological tissue changes with the concentration of ions in extra- and intra-cellular fluids, Cellular structure and density, molecular composition, membrane characteristics and other factors can be found in [2]. Consequently, they reflect structural, functional and pathological conditions of the tissue and can provide valuable diagnostic information. Hence the electrical behavior of a tissue can be examined by its Bio-impedance data.

Throughout the history to the present viewpoint of modern science, Electrical Bio-impedance have been a part of medical applications like Impedance Cardio Graphy (ICG) or Electrical Impedance Plethysmography (EIP); a technique used to detect the electrical properties of blood flow in the Thorax and

Electro EncephaloGraphy (EEG); a measurement which shows the electrical activity of brain. The evolution, history and developments in electrical technology relating to measurement of Bio-impedance can be found in [2], [3], [4], and [5].

Impedance Z (ohm, Ω) is a general electrical term relating the ability to oppose ac current flow; it is expressed as the ratio of an ac sinusoidal voltage to an ac sinusoidal current in an electric circuit. It is a complex quantity because in the time-domain a biomaterial has the properties of opposing the flow of current and it also phase-shifts the voltage with respect to the current. Admittance Y (Siemens, S) is the in-verse of impedance ($Y=1/Z$), a common term for impedance and admittance is immittance.

A biomaterial may be living tissue, dead tissue, or organic material related to any living organism such as a human, animal, cell, microbe, or plant. But here the description is limited to human body tissue [6].

A living tissue can be characterized either as dielectric or electrolytic substance. It consists of cells with poor conductivity, thin-cell membranes; therefore, tissue has resistive and capacitive properties. These properties depend on the frequency of signal applied and the electrolyte solution surrounding the cells. "An electrolyte is a substance with ionic dc conductivity" [2]. The tissue impedance inversely varies with the frequency of the signal, the higher the frequency, the lower the impedance. The electrical properties of tissue are dual in nature depending on the low or high frequency. The human body contains water and naturally the cells thus, when an electrical current signal is passed through the body, the water-containing fluids primarily conduct the electrical current. The water is found both inside the cells, Intra Cellular Fluid (ICF) and outside the cells, Extra Cellular Fluid (ECF).¹

At low frequency (<1MHz) range, current passes through the ECF space and does not penetrate the cell membrane (see Fig 1) thus the resultant immittance of tissues are predominantly electrolytic. In electrolyte solutions tissue and electrodes have some special properties in common: a more or less a constant phase character. Thus at low frequencies the tissue electrolytes are electrolytic conductors, with ions free to migrate, and with considerable dc conductivity. On the other hand at high frequency range, the current passes through both

Towfeeq Fairouz is now with the Department of Electrical Engineering, Al-Margeb University, Al-Khoms, Libya (phone: +218-922778280; e-mail: towfeeq.fairouz@gmail.com).

Salim Istyaq is with the Computer Engineering, University Polytechnic Aligarh Muslim University, Aligarh India. (e-mail: saleemishtiyak@gmail.com).

¹ [Online] www.bioimpedance.com

ICF and ECF and the resultant immittance will be dominated by the dielectric properties of tissues. A dielectric is a material placed between the plates of capacitor through which electric field penetrates when applied, which is not true for conductors in a static electric field. But at highest frequency, tissue properties become similar to that of water and the characteristic relaxation frequency of pure water is approximately 18 GHz.

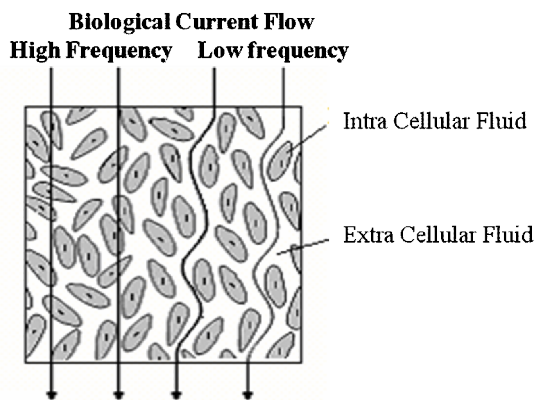

Fig. 1 Biological Current Flow

Thus the tissue property may be regarded as a conductor or dielectric depending upon the choice of frequency. An electrolytic conductor is characterized by immittance and a dielectric by permittivity or capacitance. However the conductivity may be complex and thus take care of capacitive component as well, permittivity and capacitance may be complex and also take care of conductance. Muscle tissue is more a conductor with certain capacitive properties; stratum corneum is more a dielectric with certain conductive properties. A situation that is confusing for the users of bio-impedance data such as medical doctors because some bio-impedance groups characterize tissue by immittance terminology, others by dielectric terminology. A dermatologist is confronted with skin characterized by a number of parameters such as capacitance, permittivity, impedivity, impedance, resistivity, resistance, reactance, admittivity, admittance, conductivity, conductance or susceptance. These are different, but possible correct ways of describing a biological material.

While dealing with linear systems, the description of permittivity or immittivity contains the same information. It must also be realized that permittivity and immittivity are material constants, whereas immittance is the directly measured quantity dependent on tissue and electrode geometries. In a heterogeneous biomaterial, the distribution of immittivity within the material cannot be gathered from the spectrum of measured immittance. An important task in the bio-impedance area is to base data interpretation on a better knowledge of the immittivity of the smaller tissue components. The more detailed explanation of tissue properties can be found in [2].

II. TYPES OF BIO-IMPEDANCE MEASUREMENTS

The impedance of a biological tissue consists of resistance and the reactance. The conductive characteristics of body fluids provide the resistive component, whereas the cell membranes, acting as imperfect capacitors, contribute a frequency-dependent reactive component.

Indirectly, impedance can be measured in terms of *Admittance* as $1/Z = I/V$ (current upon voltage) equal to Y .

$$Y = G + j\omega C_p \quad (1)$$

$$\phi = \tan^{-1}(\omega C_p) \quad (2)$$

$$|Y|^2 = G^2 + (\omega C_p)^2 \quad (3)$$

Where ϕ is the phase angle indicating to what extent the voltage is time-delayed, G is the parallel conductance (S), and C_p the parallel capacitance (F). The term ωC_p is the capacitive susceptance

Impedance is the inverse of admittance ($Z = V/I = 1/Y$), the equations are:

$$Z = R_s - \frac{j}{\omega C_s} \quad (4)$$

$$\phi = \tan^{-1}\left(\frac{-1}{\omega R_s C_s}\right) \quad (5)$$

$$|Z|^2 = R_s^2 + \left(\frac{1}{\omega C_s}\right)^2 \quad (6)$$

The term $-1/\omega C_s$ is the capacitive reactance and the values of the series (R_s , C_s) components values are not equal to the parallel ($1/G$, C_p) values:

$$Z = R_s - \frac{j}{\omega C_s} = \frac{G}{|Y|^2} - \frac{j\omega C_p}{|Y|^2} \quad (7)$$

Here R_s and C_s are both frequency dependent where as G and C_p is not. The above equations (7) and (6) give the notion that, impedance is a series circuit of a resistor and a capacitor, and admittance is a parallel circuit of a resistor and a capacitor. And the measurement results must be given according to one of these models. A model must be chosen, no computer system should make that choice. An important basis for a good choice of model is deep knowledge about the system to be modelled. An electrical model is an electric circuit constituting a substitute for the real system under investigation, as an equivalent circuit [6].

Equivalent Circuit: The distribution of impedance within the tissue cross section is represented by distributed equivalent circuit model of Fig 2. The most simple equivalent circuit of a tissue consists of an R-C series circuit in which the resistance (R_i) models the contribution of the intracellular fluid, and the

capacitance (C_m) represents the dielectric properties introduced by the cell membrane. This series model is shunted by a parallel resistance (R_e) that depends on the content of extracellular fluid. This model is also known as Cole or Cole-Fricke-Cole (CFC) basic dipole used for traditional body modelling [7].

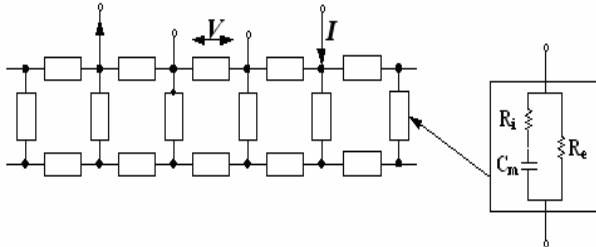

Fig. 2 Equivalent circuit model or Cole or Cole-Fricke-Cole (CFC)

A. Electrode System

Biological systems have been studied using electrical impedance measurements with an aim to correlate the electrical parameters with tissue structure or physiological events. Bridge techniques and phase-sensitive detectors were used in along with two or four electrode systems. But these measurements were not suited when the impedances change rapidly and were time-consuming. Bridge technique has an advantage of high resolution and accuracy but has the difficulty of obtaining the balanced condition. [8].

Using two, three or four electrodes, there are a variety of techniques available for measuring electrical bio-impedance. Any of those techniques uses Ohm's law to find the relationship Z between the current I across the sample and the voltage drop in the sample V . Please submit your manuscript electronically for review as e-mail attachments. When you submit your initial full paper version, prepare it in two-column format, including figures and tables.

$$V = I \times Z \quad (\text{Ohms law}) \quad (8)$$

Fig 3 shows the three most common electrode systems. With two electrodes, the current carrying electrodes (CC) and signal pick-up (PU) electrodes are the same (Fig 3 c). If the electrodes are equal, it is called a bipolar lead, in contrast to a monopolar lead.

With three (Tetra-polar) electrode system, one common measuring electrode is used for both current carrying and signal pick-up (Fig 3 b), where as for four-(Quadra polar) electrode system, separate current carrying and signal pick-up electrodes (Fig 3 a) exists and the impedance is considered as transfer impedance. With ideal voltage amplifiers, the PU electrodes are not current carrying, and therefore their polarization impedances do not introduce any voltage drop disturbing measured tissue impedance.

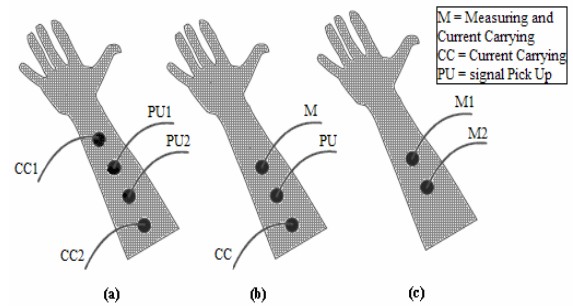

Fig. 3 Three skin surface electrode systems on an underarm [6]

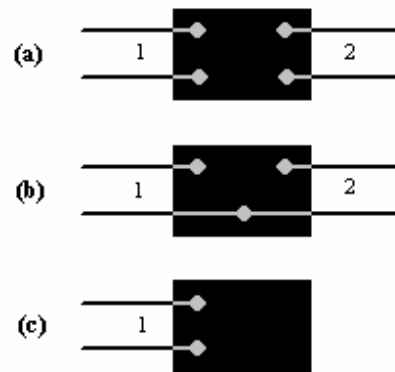

Fig. 4 Black Box Models for Fig 3

The corresponding black box models of Fig 3 are shown in Fig 4. According to the reciprocity theorem it is surprising that the measured immittance will be same if the CC and PU electrodes are interchanged [6]. A Detailed explanation of Electrode measurement system is given in [2].

B. Four-Electrode Method (Tetra-polar electrode system)

Biological systems have been studied using electrical impedance for a homogeneous isotropic tissue; the experimental evaluation of its impedance is often performed using the four-electrode method (Fig 5). When an alternating current is passed through the electrode, impedance due to electrode polarization is generated which gets added to the measurement of sample and electrode tissue interface. This results in over estimation of sample impedance. The effective elimination of this electrode polarization impedance can be achieved using four-electrode technique. It is the most robust measurement setup accomplished by using separate electrode pairs for current injection (I_0, I_1) and for voltage sensing (V_a, V_b) as in Fig 2.4. The voltage is measured with a very high input impedance so as to prevent the flow of current in sensing electrodes. Much of the instrumentation techniques for impedance measurements have been extensively reviewed by Ackmann [9] and Schwan [10].

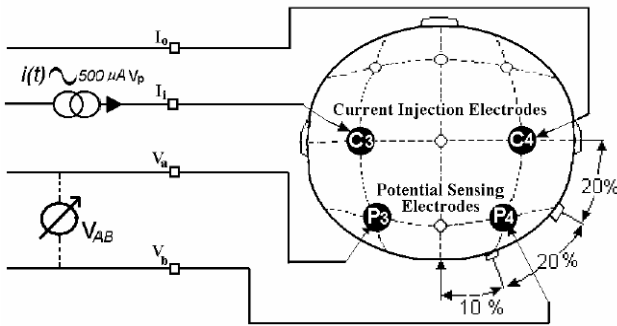

Fig. 5 A Typical Four-electrode technique for measuring electrical Bio-impedance [11]

III. ESTIMATION TECHNIQUES

The first technique is based on Fourier analysis and makes use of the FFT (Fast Fourier Transform) as a tool to estimate the impedance value (Z) in the frequency domain. The second technique is Sine-Correlation analysis and makes use of correlation method to estimate the resistance (R) and the reactance (X) in time domain. The last technique is Digital Deconvolution also known as Phase and Quadrature decomposition technique and makes use of the TLS (Total least square) method to estimate the resistance (R) and the reactance (X) in time domain.

A. Fourier Signal Analysis

This approach estimates the complex electrical impedance in polar form i.e. magnitude and phase. The basis of this method is to compute the FFT of the two observed signals and calculate from the obtained spectra the amplitude relationship and phase difference at the measurement frequency.

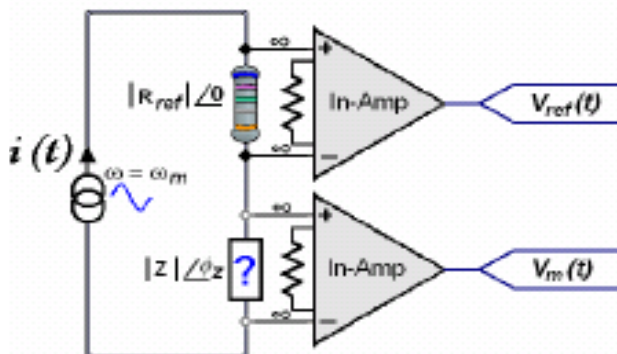

Fig. 6 Measurement setup for 4-electrode technique with FFT analysis approach

According to Fig 6, the observed voltage signals are $v_m(t)$ and $v_{ref}(t)$, where $v_m(t)$ is voltage drop in the impedance under study and the $v_{ref}(t)$ is the voltage drop in a reference resistor (R), with 0^0 phase angle. Such signal is used as a reference signal to calculate the instantaneous current value going through impedance under study $i(t)$, where $i(t)$ is a pure tone at the measurement frequency ω_m .

Now the Fast Fourier transform is applied over these two signals and from the spectral information of them the

magnitude and phase of the impedance is calculated at the measurement frequency ω_m according to the following development.

$$v_{ref}(t) = i(t) \times |R_{ref}| \angle 0^0 \xrightarrow{\text{Fourier}} V_{ref}(\omega) = I(\omega) \times |R_{ref}| \angle 0^0 \quad (9)$$

$$v_m(t) = i(t) \times |Z| \angle \phi_z \xrightarrow{\text{Fourier}} V_m(\omega) = I(\omega) \times |Z| \angle \phi_z \quad (10)$$

$$V_m(\omega) = \frac{V_{ref}(\omega) \times |Z| \angle \phi_z}{|R_{ref}| \angle 0^0} \text{ as } i(\omega) = \frac{V_{ref}(\omega)}{|R_{ref}| \angle 0^0} \quad (11)$$

As $i(t)$ is a sine wave at natural frequency

$$\omega = \omega_m \Rightarrow I(\omega)_{\omega=\omega_m} = |I_{amplitude}| \times 1 \angle -\pi/2 \quad (12)$$

$$\text{Therefore, } V_{ref}(\omega)_{\omega=\omega_m} = |V_{ref \text{ amplitude}}| \angle -\pi/2 \quad (13)$$

$$V_m(\omega)_{\omega=\omega_m} = |V_m \text{ amplitude}| \angle (\phi_z - \pi/2) \quad (14)$$

and finally

$$Z|_{\omega=\omega_m} = \begin{cases} |Z| = \frac{|V_m \text{ amplitude}|}{|V_{ref \text{ amplitude}}|} \times |R_{ref}| \\ \angle Z = \angle V_m(\omega_m) - \angle V_{ref}(\omega_m) + \angle R_{ref} \\ = (\phi_z - \pi/2) - (-\pi/2) + 0^0 \\ = \phi_z \end{cases} \quad (15)$$

How the effect of noise is reduced?

Fast Fourier Transform (FFT) has many features and one of which is that it reduce or completely removes the content of noise present in the signal. Here in Fourier analysis method Additive White Gaussian Noise (AWGN) is added to single tone signal in time domain and then FFT is applied so as to transform it in frequency domain. As a result of this transformation the white noise energy in the signal gets smeared over the frequency spectrum band. There will be equal energy at each frequency and as the number of FFT points increases, the noise voltage at each frequency gets reduced. And when the magnitude of spectrum is picked at measurement (single) frequency it contains little amount of noise or can say zero amount if FFT points are increased to a desired level. For every doubling of the Fourier Transform length Signal to Noise Ratio (SNR) improves by 3dB and

Noise goes down by $\sqrt{2}$.²

B. Digital De-Convolution Analysis

This approach estimates the complex impedance in Cartesian form, resistance and reactance. The signal analysis uses the fact that the observed signal is built up by two components. The in-phase component is voltage drop in the resistive part of the impedance, where both the voltage and current signals are "in-phase" i.e. phase shifted by 0^0 and the quadrature component is the voltage drop in the reactive part of the impedance, where voltage and current are in "quadrature" i.e. phase shifted by $\pi/2$.

The measurement set-up in this approach is shown in Fig 7 which is also applicable for Sine-Correlation technique. Here the signal source generates three sinusoidal signals at the exactly the same frequency, ω_m : the injecting (stimulus) current going through the tissue under study $i(t)$ and two reference voltage signals; one "in-phase" and another "in-quadrature" with $i(t)$. This measurement set up resembles the Sine-Correlation analysis and the difference comes while applying methods. If the TLS method is applied to above generated signals it is termed as Digital De-Convolution (TLS) technique and if, the correlation method is applied then it is termed as Sine-Correlation technique.

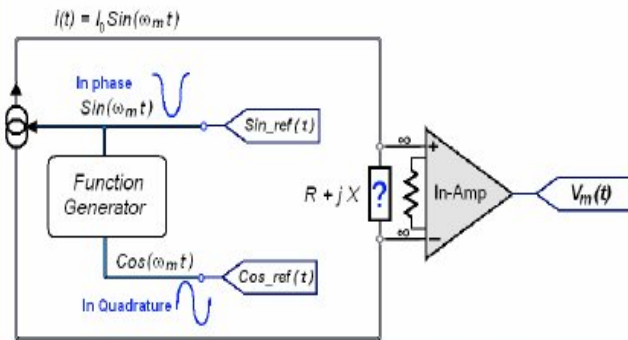

Fig. 7 Measurement setup for four-electrode technique with Digital De-Convolution Analysis

The in-phase and quadrature system is defined by the following equations:

$$V_m(t) = i(t) \times Z(\omega) \quad (16)$$

$$V_m(t) = I_o \sin(\omega_m t) \times Z(\omega_m) \text{ where } \omega = \omega_m \quad (17)$$

$$Z(\omega_m) = R_z(\omega_m) + jX_z(\omega_m) \quad (18)$$

$$\underbrace{I_o \sin(\omega_m t) \times R_z(\omega_m)}_{\text{In phase component}} + \underbrace{I_o \cos(\omega_m t) \times X_z(\omega_m)}_{\text{In quadrature component}} = V_m(t) \quad (19)$$

The equation (19) in matrix form is

² [Online] <http://www.dsprelated.com>

$$\begin{bmatrix} \overbrace{I_o \sin(\omega_m t)}^{i_{-P}(t)} & \overbrace{I_o \cos(\omega_m t)}^{i_{-Q}(t)} \end{bmatrix} \times \begin{bmatrix} R_z(\omega_m) \\ X_z(\omega_m) \end{bmatrix} = [V_m(t)] \quad (20)$$

$$[I]_{n \times 2} \times [Z] = [V_m]_{n \times 1} \quad (21)$$

n is the number of observed samples.

Errors are expected in the observations, both in the current matrix \mathbf{I} and the measurement matrix \mathbf{V}_m , therefore the system matrix equation goes from

$$I \times Z = V_m \xrightarrow{I \times Z \approx V_m} (I + I) \times Z = V_m + V_m \quad (22)$$

In order to estimate the value of the impedance matrix \mathbf{Z} from the available observations, the TLS method is used as follows.

$$I_{n \times 2} \times Z_{2 \times 1} \approx V_m \Rightarrow [I | V_m] \times \begin{bmatrix} \hat{Z} \\ -1 \end{bmatrix} \approx 0 \quad (23)$$

$$SVD([I | V_m]) = U \times \text{diag}(\sigma_1, \sigma_2, \sigma_3) \times V^T = [I | V_m] \quad (24)$$

Best approximation for

$$[\hat{I} | \hat{V}_m] = [I | V_m] - [\nabla \hat{I} | \nabla \hat{V}_m] \quad (25)$$

$$[\hat{I} | \hat{V}_m] = U \times \text{diag}(\sigma_1, \sigma_2, \sigma_3) \times V^T \quad (26)$$

$$[\nabla \hat{I} | \nabla \hat{V}_m] = [I - \hat{I} | V_m - \hat{V}_m] = u_3 \times \sigma_3 \times v_3^T \quad (27)$$

$$[\hat{I} | \hat{V}_m] v_3 = 0 \xrightarrow{\text{TLS-solution}} [\hat{I} | \hat{V}_m] \times \begin{bmatrix} \hat{Z} \\ -1 \end{bmatrix} = 0$$

$$\Rightarrow \begin{bmatrix} \hat{Z} \\ -1 \end{bmatrix} = -\frac{v_3}{v_{3,3}} \quad (28)$$

$$\text{Therefore } R_z = -\frac{v_{1,3}}{v_{3,3}} \quad (29)$$

$$\text{and } X_z = -\frac{v_{2,3}}{v_{3,3}} \quad (30)$$

How the effect of noise is reduced?

When the noise (AWGN) is added to the signal it is assumed that this noise contributes errors in the observation signals. Optimizing these errors is same as minimizing noise effects which is attained using Total Least Squares (TLS) approximation. TLS is a mathematical optimization technique to estimate the value of variables using linear model. It offers a proper formulation by assuming that the variables of linear equation are affected by independent and identically distributed noise. In Digital De-Convolution analysis, TLS approximation is applied using Singular Value Decomposition, a suitable factorization to optimize the value of impedance when the errors are expected in the observations. This optimization process extracts minimum (Least Mean Squares) value from a set of possible observed values and obviously the minimum value will have the least error. As such the effect of noise is reduced using TLS approximation and SVD factorization on observed noisy signals [12].

C. Sine-Correlation Analysis

Sine-Correlation technique also estimates the complex impedance in Cartesian form, resistance (real) and reactance (imaginary). For electrochemical measurements where the signal levels are often small (mV and nA), the signals being measured are often buried in noise. This technique (sine correlation) is excellent at extracting the required signal component from noise hence it is also known as frequency response analysis technique.³ The measurement set up for four-electrode technique with Sine-Correlation analysis is shown in Fig 8 and the development equations are as follows:

$$V_m(t) = i(t) \times Z(\omega)$$

$$V_m(t) = I_o \sin(\omega_m t) \times Z(\omega_m) \text{ where } \omega = \omega_m \quad (31)$$

$$\text{Where } Z(\omega_m) = R_z(\omega_m) + jX_z(\omega_m) \quad (32)$$

$$V_m(t) = I_o \sin(\omega_m t) \times R_z(\omega_m) + I_o \cos(\omega_m t) \times X_z(\omega_m) \quad (33)$$

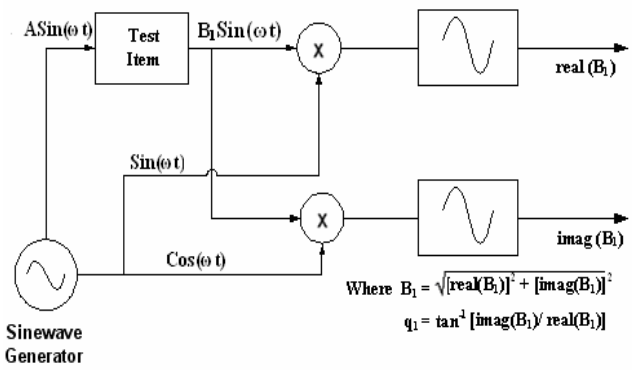

Fig. 8 Measurement setup for Four-electrode technique with Sine-Correlation Analysis

Adding AWGN (Additive White Gaussian Noise) to gives

$$V_{mN}(t) = I_o \sin(\omega_m t) \times R_z(\omega_m) \dots \dots + I_o \cos(\omega_m t) \times X_z(\omega_m) + \text{Noise} \quad (34)$$

When Correlating $V_{mN}(t)$ with $\sin(\omega_m t)$ and averaging the result gives the real part (R_{est}) of estimated impedance (Z_{est}) as follows

$$V_{mN}(t) \times \sin(\omega_m t) = \left(I_o \sin(\omega_m t) \times R_z(\omega_m) \dots \dots + I_o \cos(\omega_m t) \times X_z(\omega_m) + \text{Noise} \right) \times \sin(\omega_m t)$$

$$V_R = I_o R_z \sin^2(\omega_m t) + I_o X_z \cos(\omega_m t) \sin(\omega_m t) + \text{Noise} \quad (35)$$

Using double angle relations $\sin 2\alpha = 2 \sin \alpha \cos \alpha$ and $2 \sin^2 \alpha = 1 - \cos 2\alpha$

$$V_R = \frac{I_o R_z}{2} (1 - \cos(2\omega_m t)) + \frac{I_o X_z}{2} (\sin(2\omega_m t)) + \text{Noise}$$

$$V_R = \frac{I_o R_z}{2} - \frac{I_o R_z}{2} (\cos(2\omega_m t)) \dots \dots + \frac{I_o X_z}{2} (\sin(2\omega_m t)) + \text{Noise} \quad (36)$$

Upon averaging over a period of signal gives V_{avgR} as

³[Online]
<http://www.solartronanalytical.com/downloads/technotes/impedtech.pdf>

$$V_{avgR} = \int \left[\frac{IoR_z}{2} - \frac{IoR_z}{2} \int \cos(2\omega_m t) \dots \right. \\ \left. \dots + \frac{IoX_z}{2} \int \sin(2\omega_m t) + \int (Noise) \right] dt \quad (37)$$

$$V_{avgR} = \frac{IoR_z}{2} \quad (38)$$

And Estimated Resistance is $R_{est} = \frac{2V_{avgR}}{Io}$ (39)

Similarly, when Correlating $V_{mN}(t)$ with $\cos(2\omega_m t)$ and averaging the result gives the imaginary part (X_{est}) of estimated impedance (Z_{est}) as follows

$$V_{mN}(t) \times \cos(\omega_m t) \\ = \left(\begin{aligned} &Io \sin(\omega_m t) \times R_z(\omega_m) \dots \\ &\dots + Io \cos(\omega_m t) \times X_z(\omega_m) + Noise \end{aligned} \right) \times \cos(\omega_m t)$$

$$V_X = IoR_z \sin(\omega_m t) \cos(\omega_m t) \dots \\ \dots + IoX_z \cos^2(\omega_m t) + Noise \quad (40)$$

Using double angle relations $\sin 2\alpha = 2\sin \alpha \cos \alpha$ and $2\cos^2 \alpha = 1 + \cos 2\alpha$

$$V_X = \frac{IoR_z}{2} (\sin(2\omega_m t)) \dots \\ \dots + \frac{IoX_z}{2} (1 + \cos(2\omega_m t)) + Noise$$

$$V_X = \frac{IoR_z}{2} (\sin(2\omega_m t)) + \frac{IoX_z}{2} \dots \\ \dots + \frac{IoX_z}{2} (\cos(2\omega_m t)) + Noise \quad (41)$$

Upon Averaging over a period of signal gives V_{avgX} as

$$V_{avgX} = \frac{IoR_z}{2} \int \sin(2\omega_m t) + \int \frac{IoX_z}{2} \dots \\ \dots + \frac{IoX_z}{2} \int \cos(2\omega_m t) + \int Noise \quad (42)$$

$$V_{avgX} = \frac{IoX_z}{2} \quad (43)$$

And the estimated reactance $X_{est} = \frac{2V_{avgR}}{Io}$ (44)

How the effect of Noise is reduced?

This technique consists of two processes, correlating and averaging. The first one completely rejects harmonics and dc offsets while the later significantly reduces the noise effects by the selection of appropriate integration times. Those things are achieved by correlating the input signal with reference sine waves and integrating the result over a number of complete cycles of the sine wave. Using this technique very small signal can be identified in the presence of very high levels of harmonics and noise. Also if the measurements are taken at exactly the same time on each input (in parallel) any errors due to variations in the signals with the time are cancelled.

When a pure sine wave signal is applied to a test cell (impedance) the amplitude of signal either increases or decreases depending on the test cell. If the noise (Gaussian) is added to this signal then the resultant signal waveform will often get distorted due to the random behaviour of added noise. Generally these measurements are done using small AC signals so as to limit these effects as much as possible with ideal conditions. But anyhow some unavoidable harmonic distortion is included besides some noise superimposed due to the low level of signal being applied. As a result the output waveform from the test item is distorted containing some second and third harmonic frequency components. In some cases though, some degree of harmonic distortion is unavoidable and some noise superimposed due to the low level of stimulus being applied. As such the 'response waveform' output from the test item, is a distorted waveform containing some second and third harmonic frequency components. The correlation process filters out those unwanted components and gives the required signal frequency component which is free from distortion.³

The resultant signals V_{avgR} and V_{avgX} shows that only DC values $IoR_z/2$ and $IoX_z/2$ remains respectively while double (higher) frequency terms including noise gets completely eliminated as a result of correlation and integration. The average value of double frequency terms becomes equal to zero and hence they are completely eliminated. On the other hand the added noise to the signal is AWGN with zero mean and upon averaging it gets completely reduced.

IV. IMPLEMENTATION IN MATLAB™

Each method is implemented in Matlab™ with the help of respective development equations. Each method is designed to estimate the impedance Z and then different relative errors like magnitude, phase, resistive and reactive are calculated so as to plot their absolute values with respect to SNR (dB). In order to compare the performance of the methods, it is necessary that the input parameters (or variables), data supplied to them, estimated relative errors and their respective plots should be same. Hence the initialisation function, different error

functions and their respective plotting functions of the code are common irrespective of the method chosen.

Initial Parameters

Some parameters that are considered global to the methods used and functions used to estimate the Impedance Z .

Impedance (z): It is an array of original impedance values on which the estimation is performed.

The Measurement frequency (f_m)

The Signal Amplitude (I_o)

The number of periods of the measurement (N_{per})

Number of samples per period (S_{per})

The Processing Time (t_{lim}): It is not the input parameter but it is generated within the code as follows

$$t_{lim} = N_{per} \times \frac{1}{f_m} \quad (48)$$

Sampling frequency (f_s): This parameter is also generated by code as follows

$$f_s = S_{per} \times f_m \quad (49)$$

Sampling time (t_s): It is inverse of sampling frequency and generated by code as follows

$$t_s = \frac{1}{f_s} \quad (50)$$

Input Signal (i): A single tone current signal with a measurement frequency f_m and amplitude I_o represented as

$$i(t) = I_o \sin(\omega_m t) \quad (51)$$

where $\omega_m = 2\pi f_m$, and time t , is an array created as follows $t = [0 : t_s : t_{lim}]$

Averaging factor (k): It is the loop iteration number used by each method in order to promediate the estimated (z) with the effect of noise.

Signal to Noise Ratio (snr): It is defined as the ratio of a given transmitted signal to the background noise of the transmission medium also known as D/U ratio, which stands for desired to undesired signal ratio. Here the array of SNR is created as follows

$$snr = [snr_max : -snr_step : snr_min] \quad (53)$$

where snr_max , snr_step , snr_min are respectively maximum, decreasing step size and minimum values of snr input parameters.

Standard Deviation (sd): Standard Deviation relative to signal magnitude of the random noise added to signals is an array created as follows

$$sd = \frac{I_o}{snr} \quad (54)$$

Implementation of AWGN

In all the methods two different random noise signals are generated using the function $rand()$ as shown below

$$Noise_A = sd^{2 \times} randn(size(t)) \quad (55)$$

$$Noise_B = sd^{2 \times} randn(size(t)) \quad (56)$$

These two signals (55), (56) are randomly generated, independent and identically distributed noise, i.e. the resultant numerical values of $Noise_A$ and $Noise_B$ will not be same.

A. Implementation of FFT method

The Fourier analysis method is implemented in MATLAB™ as shown in Fig 9 where the single tone current signal $I(t)$ is generated at measurement frequency ω_m and amplitude I_o . This signal gets multiplied by the reference resistor R_{ref} and original impedance Z to generate voltage signals $V_{ref}(t)$ and $V_z(t)$ respectively. Now the random noise signals of equation (55) and (56) are added to $V_{ref}(t)$ and $V_z(t)$ respectively and then the Fast Fourier transform (256 point) is applied to these noisy signals. As a result of which they are changed in frequency domain as $V_M(\omega)$ and $V_{REF}(\omega)$ respectively. By doing some mathematical calculations on these signals (Fig 4.1) and extracting the value at the measurement frequency (ω_m) gives the required estimated impedance Z . This estimated impedance is used to calculate different relative errors.

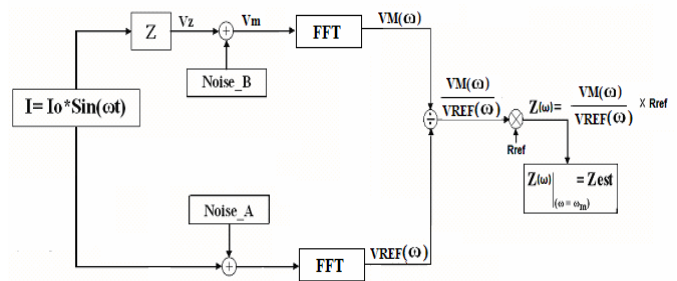

Fig. 9 Impedance Measurement Technique: Fourier (FFT) Method

B. Implementation of DD method

This method uses Total Least Squares (TLS) approximation, a mathematical optimization technique to estimate the value of impedance using linear model.

$$AX = B \quad (58)$$

According to measurement setup this method is implemented by generating three Sinusoidal signals exactly at a measurement frequency of ω_m , and amplitude I_o as shown in the Fig 10. Of these three signals one is the original current signal and two others are termed as in phase and quadrature current signals. The in phase current signal is same as original signal while the quadrature current signal is phase shifted by

90° with respect to original signal. Now the voltage signal V_z is generated when original signal gets multiplied by impedance Z . This voltage signal after being added with Gaussian Noise_B becomes coefficient B for the equation (58). The other two current signals after being added with Noise_A becomes coefficient A for the equation (58) and certainly variable X becomes the impedance Z to be estimated.

Now the TLS approximation is applied to optimize the value of impedance using suitable factorization known as Singular Value Decomposition (SVD). not be same.

C. Total Least Square (TLS) Solver

Least Squares is a mathematical optimization technique applied to a series of measured data to find a function which closely approximates the data (a "best fit"). It implicitly works if the errors in the measurement are randomly distributed and hence called as least mean squares(LMS).

Types of least square solutions, given an observation vector $B \in R^m$ and a data matrix, $A \in R^{m \times n}$ with $m > n$, consider the solution of the over determined system of equations $AX \approx B$. Then

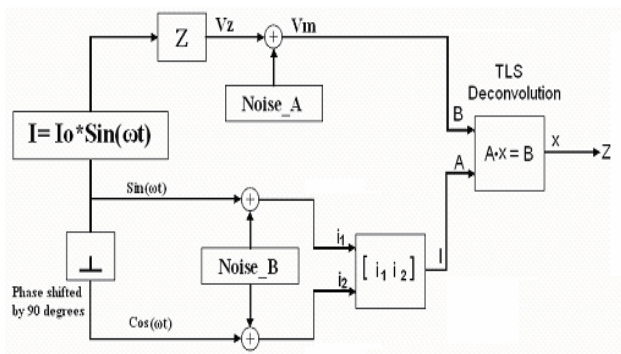

Fig. 10 Impedance Measurement Technique: Digital Deconvolution Method

Ordinary least squares (OLS): The OLS method yields the solution X that minimizes the Euclidean norm of the residuals $\|AX = B\|_2$ where $\|\cdot\|_2$ is known as the two-norm. The residual is an estimate of the error. Equivalently, the OLS problem can be paraphrased by $\min_x \|\Delta B\|_2$ subject to

$$AX = B + \Delta B \quad (59)$$

where $\|\cdot\|_2$ is the two-norm and ΔB is the perturbation used to compensate the noisy signal B .

Data least squares (DLS): The DLS method can be used alternatively when the data vector A is affected by noise and it is paraphrased by $\min_x \|\Delta A\|_F$ subject to

$$(A + \Delta A)X = B \quad (60)$$

where $\|\cdot\|_F$ is the Frobenius norm (or colloquially the "length of the vector) and ΔA is the perturbation used to compensate the noisy signal A .^{4,5}

Total least squares (TLS): The TLS method referred as Errors-in-variables (EIV), it is a robust modelling technique in statistics which assumes that both the variables A and B of linear equation can have independent and identically distributed noise. For cases where orthogonal optimization is acceptable, TLS offers a proper formulation:

$$\min_x \|\Delta A \Delta B\|_F \text{ subject to} \quad (A + \Delta A)X = B + \Delta B \quad (61)$$

where $\|\cdot\|_F$ is the Frobenius norm (or colloquially the "length of the vector) and ΔA & ΔB are the perturbation used to compensate the noisy signal A and B .

Frobenius norm: Vector norms treat a matrix as an $m \times n$ vector, and use one of the familiar vector norms.

$$\|A\|_p = \left(\sum_{i=1}^m \sum_{j=1}^n |a_{ij}|^p \right)^{1/p} \quad (62)$$

If $p = 2$, then this is called the Frobenius norm. This norm can be defined in various ways:

$$\|A\|_F^2 = \sum_{i=1}^m \sum_{j=1}^n |a_{ij}|^2 = \text{trace}(AA^H) = \sum_{i=1}^{\min\{m,n\}} \sigma_i^2 \quad (63)$$

where A^H denotes the conjugate transpose of A , and σ_i the singular values of A . A trace function is also used. The Frobenius norm is very similar to the Euclidean norm on K_n and comes from an inner product on the space of all matrices.

Now it can be concluded that TLS technique can be applied to equation (58) because the variables A and B of it are noise effected signals with white Gaussian noise.

The solution of the OLS problem can be obtained by using inverse of the data matrix. Solutions to TLS and DLS problems have been shown to be closely connected to a set of singular vectors of the (augmented) system-related matrix corresponding to the minimum singular value.^{5,6}

D. Singular Value Decomposition

In the mathematical discipline of linear algebra, matrix decomposition is a factorization of a matrix into some canonical form. There are several different decompositions of a given matrix and the decomposition used depends on the problem to be solved as well as the matrix to be factorized. In

⁴ [Online] http://en.wikipedia.org/wiki/Least_squares

⁵ [Online] <http://matrix.skku.ac.kr/ilas/er/tasw1.pdf>

⁶ [Online] http://en.wikipedia.org/wiki/Total_least_squares

numerical analysis for example different decompositions are used to implement efficient matrix algorithms, SVD is one among them whose generalization is based on the spectral theorem of arbitrary matrix, not necessarily square. It is an important factorization of a rectangular real or complex matrix.

SVD theorem states, let M is an m -by- n matrix whose entries come from the field K , which is either the field of real numbers or the field of complex numbers. Then there exists a factorization of the form

$$M = U \Sigma V^* \text{ where}$$

$$\Sigma_{i,j} = \sigma_i \quad (i = 1, 2, \dots, m = n),$$

$$\sigma_i \geq \sigma_{i+1} \text{ and } \sigma_n \neq \sigma_{n+1} \quad (64)$$

where U is an m -by- m unitary matrix over K , the matrix Σ is m -by- n with nonnegative numbers on the diagonal and zeros off the diagonal, and V^* denotes the conjugate of V , an n -by- n unitary matrix over K . Such a factorization is called a *singular-value decomposition* of M .

The diagonal entries of Σ are necessarily equal to the singular values of M . The columns of U and V are left-respectively right-singular vectors for the corresponding singular values. A common convention is to order the values $\Sigma_{i,i}$ in decreasing fashion. In this case, the diagonal matrix Σ is uniquely determined by M (though the matrices U and V are not).^{7,8}

E. Implementation of Sine-Correlation method

The signal generation in this method is much similar to the Digital De-Convolution method which is shown in Fig 11. The signal source generates three types of single tone signals with a measurement frequency ω_m and unequal amplitudes. One signal with amplitude I_0 and other two signals with unit amplitude termed as Inphase and Quadrature Signals. These unit amplitude signals after being added with white Gaussian noise are correlated with the voltage signal. The voltage signal v_z is generated when the signal with amplitude I_0 gets multiplied with impedance Z . But this voltage signal is the combination of resistive voltage v_r and capacitive voltage v_c .

Voltage v_r is across the resistor r (real part of Z) calculated normally using Ohms law and v_c is the voltage across the capacitor C calculated as follows:

$$\text{If } Z = r + jx_c \quad (65)$$

$$\text{Then } v_c = \frac{1}{C} \int i(t) dt = -\frac{1}{C} \left(\frac{I_0 \cos(\omega_m t)}{\omega_m} \right) \quad (66)$$

$$\text{and Capacitance } C = \left(\frac{-1}{\omega_m} \right) x_c \quad (67)$$

Where $\omega_m = 2\pi f_m$, and $i(t)$ is a current signal of equation (51).⁹

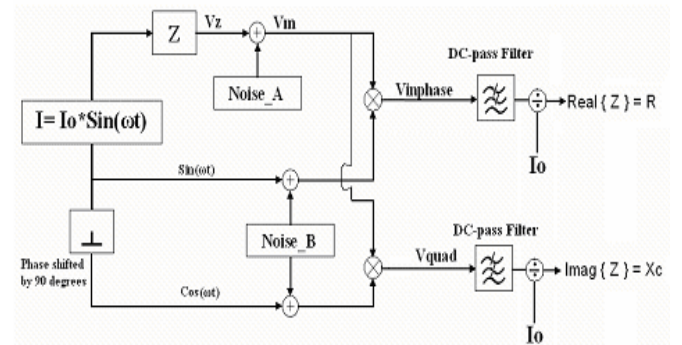

Fig. 11 Impedance Measurement Technique: Sine-Correlation Method

Now the voltage v_z is correlated with Inphase and Quadrature signals and gives out $V_{inphase}$ and V_{quad} , voltages respectively. These inphase and quadrature voltage signals when passed through the DC low pass filter gives the real and imaginary values respectively. Upon averaging these real and imaginary values with the amplitude of current gives the estimated resistance and reactance respectively.

V. SIMULATION

Flow structure

The Basic flow structure in the measurement of Electrical impedance using different methods is shown in Fig 12. The simulation starts with the initialization of data. The various methods used make use of global data input parameters to estimate the impedance Z .

Here the estimation of impedance is done using three different methods. The three methods used here are *Fast Fourier transform method (FFT)*, *Sine-Correlation method (SC)* and *Digital De-convolution method (DD)*.

Once the impedance is estimated the relative errors namely magnitude error, phase error, resistive error and reactive error are derived from the actual and estimated impedance.

Having derived the relative errors the plotting is done between absolute value of relative error and *snr* (signal to noise ratio) of the added noise.

⁷ [Online] http://en.wikipedia.org/wiki/Singular_value_decomposition

⁸ [Online] http://en.wikipedia.org/wiki/Matrix_factorization

⁹ [Online] <http://en.wikipedia.org/wiki/Capacitors>

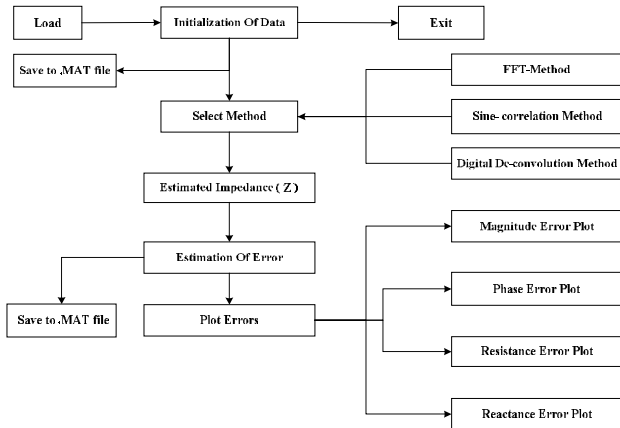

Fig. 12 Flow structure for Estimation of Electrical Impedance using various methods

Performance Test-Impedance Angle Effect

Table I below show the input, output and noise signal parameters used to test the performance of three techniques in estimating the Impedance angle effect test. The parameters are measurement frequency (f_m), amplitude (I_o), number of periods (N_{per}), samples per period (S_{per}) etc.

f_m	I_o	N_{per}	S_{per}	k	Snr (range)	Snr(range) dB
100	10	4	10	100	[20:10]	[26:20]

Z	z	$\theta^\circ(z)$
90-15*i	91.2414	-9.5
70-50*i	86.0233	-35.5
20-20*i	28.2843	-45
70-700*i	703.4913	-84.3

The test is performed on four different impedance values. The impedance values, their magnitude and phase are shown in the Table II. The number of FFT points used in Fourier analysis method is 256.

Results and Discussion

The Basic In this section the estimation error obtained from the performed test are plotted and each method's performance is compared and discussed

Magnitude Estimation

Fig 13 (a), (b), (c) shows the performance of three techniques estimating the module of the impedance. The plots show the obtained estimation error versus snr when estimating module for different impedance values of Table II.

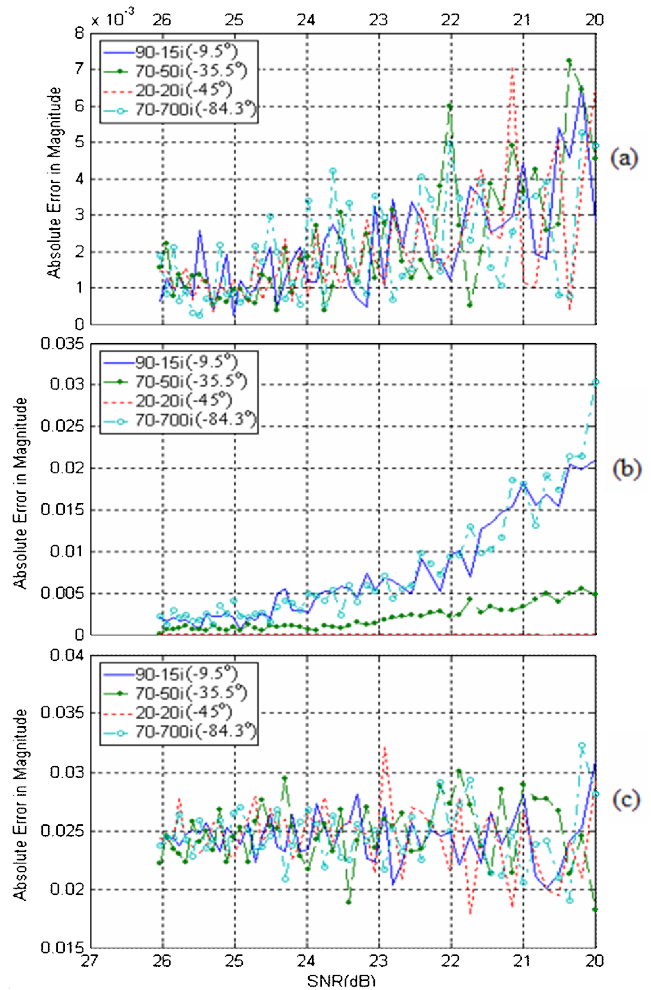

Fig. 13 Magnitude Plots using (a) FFT method (b) DD method (c) SC method

Fig 13 (a) contains the magnitude estimation error data from FFT method, Fig 13 (b) from DD method and Fig 13 (c) from SC method.

When observing the three plots it is seen that the performance of FFT and DD are better than SC. The error magnitude in FFT and DD exhibits certain dependency on increasing noise level (or decrease of snr) while in SC it starts at 0.022 and fluctuates between 0.02 and 0.03. A large amount of error is observed in SC than FFT and DD.

The small amount of error is observed in DD method for angles nearer to -45° and it is equal to zero for -45° angle. Comparing FFT and DD for four impedances at any noise level, FFT estimation works better than DD as it shows an error which is 3 times smaller than error in DD.

Phase Estimation

Fig 14 shows the performance of three techniques estimating the phase of the impedance. The plots show the obtained estimation error versus snr when estimating phase for different impedance values of Table II.

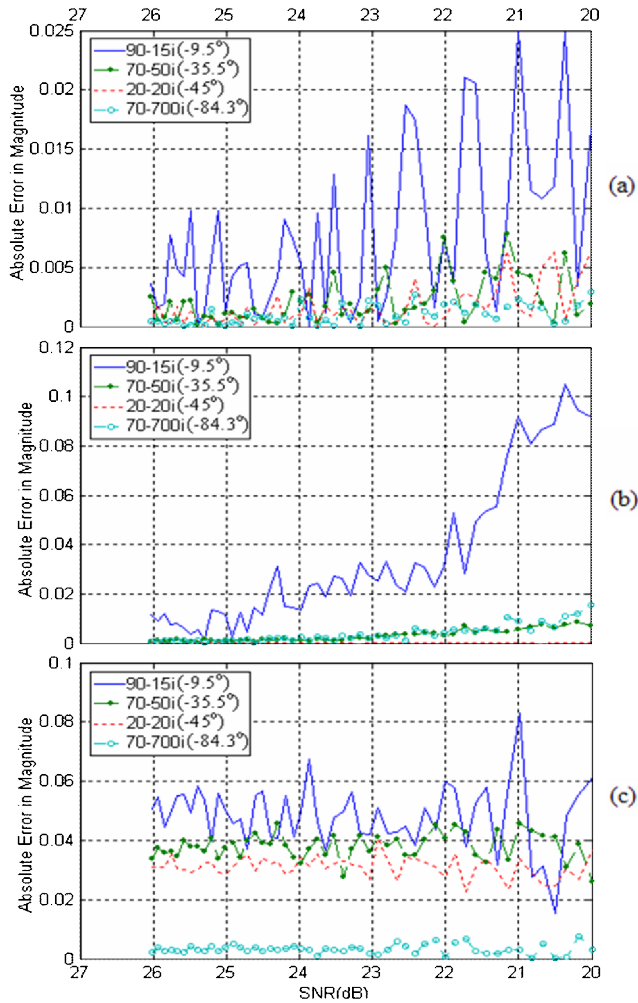

Fig. 14 Phase Plots using (a) FFT method (b) DD method (c) SC method

Fig 14 (a) contains the phase estimation error data from FFT method, Fig 14 (b) from DD method and plot Fig 14 (c) from SC method.

In all the three methods the observed phase error depends on the impedance angle of the estimated impedance. It is large for smaller angles and vice versa. But it is equal to zero in DD for -45° angle.

The error increases in accordance to noise level in FFT and DD but it fluctuates in SC between different levels for different values of impedances. The overall performance of FFT is more robust than DD and SC.

Resistance Estimation

Fig 15 shows the performance of three techniques estimating the resistive part (in phase component) of the impedance. The plots show the obtained estimation error versus *snr* when estimating resistive part for different impedance values of Table II.

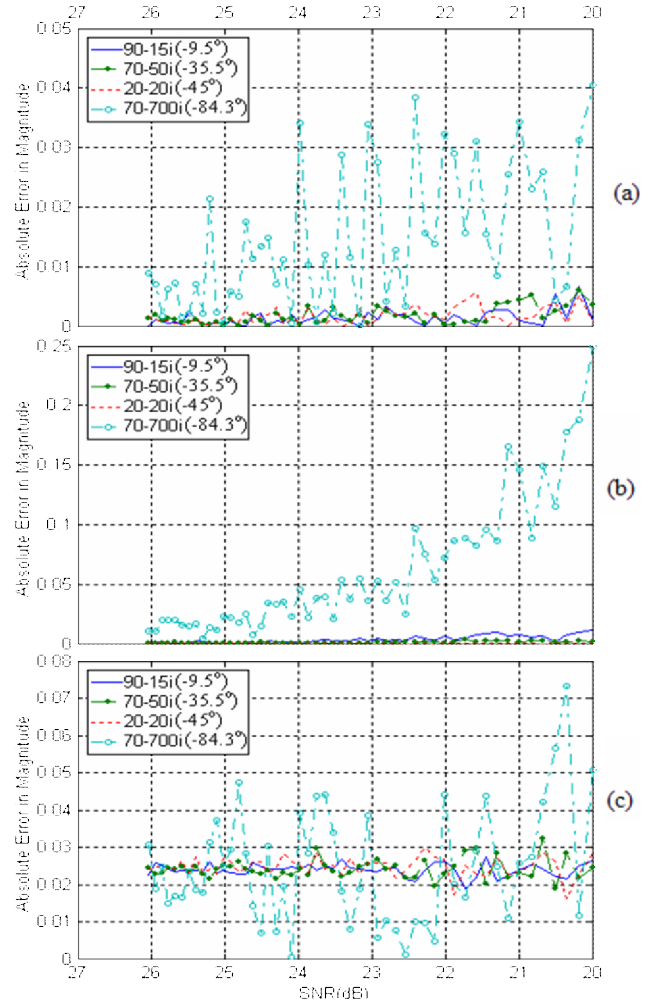

Fig. 15 Resistance Plots using (a) FFT method (b) DD method (c) SC method

Fig 15 (a) contains the resistive estimation error data from FFT method, Fig 15 (b) from DD method and Fig 15 (c) from SC method.

Larger is the impedance angle higher is the estimation error and vice versa i.e. when the resistance is much smaller than the reactance. The amount of error is almost equal to zero for DD at an angle of -45° .

SC plot performance shows that great amount of fluctuations are observed for larger angles i.e. for -84.3° . As a whole FFT method performs with most accuracy and highest robustness against noise impedances.

Reactance Estimation

Fig 16 shows the performance of three techniques estimating the reactive (in quadrature component) part of the impedance. The plots show the obtained estimation error versus *snr* when estimating reactive part for different impedance values of II.

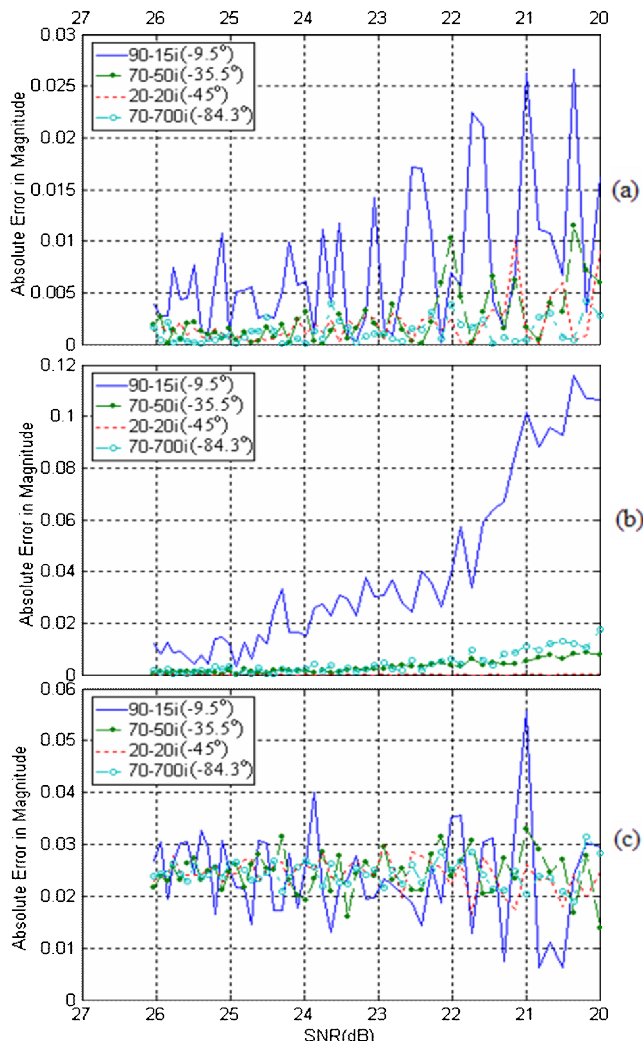

Fig. 16 Reactance plots using (a) FFT method (b) DD method (c) SC method

Fig 16 (a) contains the reactive estimation error data from FFT method, Fig 16 (b) from DD method and Fig 16 (c) from SC method.

Similar to the previous resistive estimation the performance of reactive estimation in all the three plots (see Fig 15) exhibits certain dependency on the impedance angle of the estimated impedance. Smaller is the impedance angle higher is the estimation error and vice versa i.e. when the reactance is much smaller than the resistance. The amount of error is almost equal to zero for DD at an angle of -45° .

Fluctuations are observed in SC and a greater amount is seen for smaller angles i.e. for -9.5° . As a whole FFT method performs with most accuracy and highest robustness against noise.

VI. CONCLUSIONS AND FUTURE WORK

After performing the above tests it is concluded that the Frequency analysis approach, making use of 256 point FFT, performs better estimating the overall impedance. When compared to DD and SC, FFT approach exhibits higher accuracy in presence of noise. But if only DD and SC are

compared DD performs much better than SC for increasing values of noise.

The proposed study for the future could be to improve the performance of FFT and DD methods. FFT estimator can be improved by increasing the number of FFT points from 256 to 512. The DD estimator can be improved by making use of another TLS method instead e.g. Generalized TLS or Structured TLS.

REFERENCES

- [1] "Development of Electrical Bioimpedance Technology in Future" Proceedings of the 20th Annual Conference of the IEEE Engineering in Medicine and Biology Society, Vol 20, No 2, 1998.
- [2] Sverre Grimnes, Orjan Grottem Martinsen 2000 *Bioimpedance and Bioelectricity Basics* (San Diego, CA: Academic)
- [3] "Thoracic Electrical Bioimpedance in the Outpatient Setting" Policy#:MED.00034. Medical Policy. Available: http://medpolicy.bluecrossca.com/policies/MED/thoracic_bioimpedance.html
- [4] Jaakko Malmivuo & Robert Plonsey, *Bioelectromagnetism - Principles and Applications of Bioelectric and Biomagnetic Fields*, Oxford University Press, New York, 1995. Available: <http://butler.cc.tut.fi/~malmivuo/bem/bembook/>
- [5] Herman P.Schwan and Kenneth R. Foster "Departmental Papers (BE)" Department of Bioengineering, University of Pennsylvania, Year 2002.
- [6] Sverre Grimnes, Orjan Grottem Martinsen "Bioimpedance". University of Oslo, Oslo, Norway. Available: http://www.fys.uio.no/elg/bioimp/pdf/encyc_bme.pdf
- [7] Y.Komai, E.yasuno, Y.Kinouchi,K.Izukura, T.Iritani, T.Morimoto and M.Takeuchi "Estimation of Bioimpedance Distribution in the Local Tissue Using Divided Electrodes". Seventh International Conference on Control, Automation, Robotics and Vision (ICARV'02), Dec 2002, Singapore. Available: <http://ieeexplore.ieee.org/iel5/8741/27684/01234941.pdf?tp=&arnumber=1234941&isnumber=27684>
- [8] Paul Steendijk, Gerrit Mur, Enno T, Van Der Velde, and Jan Baan "The Four-Electrode Resistivity technique in Anisotropic Media: Theoretical Analysis and Application on Myocardial Tissue in Vivo". IEEE Transactions on Biomedical Engineering, Vol. 40, NO 11, November 1993. Available: <http://ieeexplore.ieee.org/iel4/10/6298/00245632.pdf?tp=&arnumber=245632&isnumber=6298>
- [9] J.J.Ackmann and A S Seitz, "Methods of complex impedance measurements in biological tissue," CRC Crit Rev. Biom. Eng., vol. 10, pp. 281-311, 1984.
- [10] H.P.Schwan, "Determination of biological impedances," in Nastuk, Ed. *Physical Techniques in Biological Research*, New York, Academic, 1963.
- [11] Sverre Grimnes et al 2007 "Sources of error in tetrapolar impedance measurements on biomaterials and other ionic conductors" J.Phys. D: Appl. Phys. 40 9-14 doi: 10.1088/0022-3727/40/1/S02. Available: <http://www.iop.org/EJ/abstract/00223727/40/1/S02>
- [12] MD. Anisur Rahman and Kai-Bor Yu, member IEEE "Total Least Squares Approach for Frequency Estimation Using Linear Prediction" IEEE Transactions on Acoustics, Speech and Signal Processing, Vol. ASSP-35, No. 10, October 1987 Available: http://ieeexplore.ieee.org/xpls/abs_all.jsp?arnumber=1165059