

# A Novel Interpolation Scheme and Apparatus to Extend DAC Usable Spectrum over Nyquist Frequency

Wang liguo, Wang zongmin, and Kong ying

**Abstract**—A novel interpolation scheme to extend usable spectrum and upconvert in high performance D/A converters is addressed in this paper. By adjusting the pulse width of cycle and the production circuit of code, the expansion code is a null code or complementary code that is interpolation process. What the times and codes of interpolation decide DAC works in one of a normal mode or multi-mixer mode so that convert the input digital data signal into normal signal or a mixed analog signal having a mixer frequency that is higher than the data frequency. Simulation results show that the novel scheme and apparatus most extend the usable frequency spectrum into fifth to sixth Nyquist zone beyond conventional DACs.

**Keywords**—interpolation, upconversion, modulation, switching function, duty cycle.

## I. INTRODUCTION

IN today's electronic systems field, due to the speed of wireless communication systems have become increasingly demanding, so the speed requirements for the DAC have become more and more important, in order to improve the speed of the DAC, in recent years many new technologies to achieve the DAC higher performance, for example [1], [2], [3], [4].

In direct digital modulation systems, the signal is upconverted in digital domain, and the modulated digital signal is converted into a modulated analog form. In these systems, a digital-to-analog converter (DAC) whose conversion rate is more than the Nyquist rate of the carrier frequency. A wide variety of different electronic devices use a system that both converts internal digital signals to analog signals, and then shift the frequency of the resultant analog signal. For example, conventional cell phones often have a digital to analog converter chip that converts a digitally processed voice signal into an analog baseband signal for transmission. Before transmission, however, a mixer chip shifts the frequency of the baseband signal to a frequency that facilitates transmission.

An efficient solution, called interpolation is proposed for the oversampling DAC to meet the requirements for direct digital modulation in this paper. Fig.1 is the circuit based on interpolation. Section 2 discusses the theory of interpolation. Section 3 describes the control circuit about production of null code and complementary code. Section 4 presents the primary experimental results of this paper. Section 5 is the conclusion.

Wang liguo is the postgraduate of Beijing Microelectronics Technology Institute, No.2. Siyingmen N.Rd Donggaodi Fengtai District, Beijing 100076, China e-mail: ruixin2012@126.com.

Wang zongmin is with Beijing Microelectronics Technology Institute.  
 Kong ying is with Beijing Microelectronics Technology Institute.

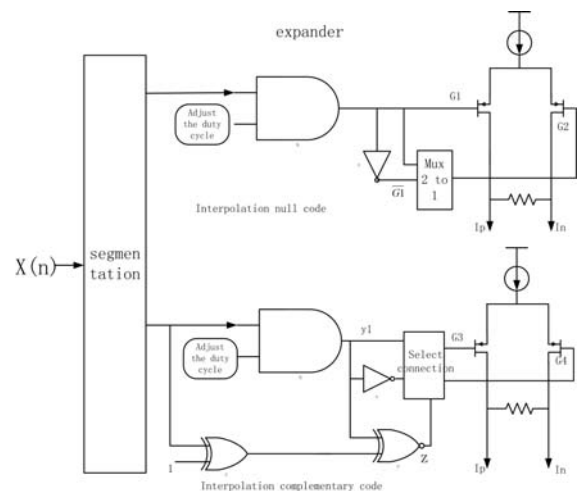

Fig. 1. Upconverting DAC architecture with interpolation

## II. INTERPOLATION THEORY

Conventional digital to analog converters translate digital signals to analog signals by holding, for each converter clock cycle, the value of the digital signals at each converter clock cycle. The corresponding spectrum is represented as being within an envelope in a response of  $\text{sinc}(\pi * f / f_{ck})$  which has null points at multiples of the clock frequency, eg.,  $1 f_{ck}$ ,  $2 f_{ck}$ ,  $3 f_{ck}$  and so on. Due to the uneven response, the usable frequency range is limited from DC, or steady-state, to half of the clock frequency where half the clock frequency, when acting as a sampling frequency, is known as and termed the Nyquist frequency. The usable frequency band is known as and termed the Nyquist band width.

A multi-rate digital expander can be used to extend the usable frequency range, that is useful linear signal processing. For example, the expander insert  $m - 1$  zero codes, or insert  $m - 1$  complementary codes, or insert zero codes and complementary codes alternately.

For a given digital  $x(n)$ , we let  $y(n) = x(n/L)$ ,  $L \in N^+$ , so  $y(n)$  is the operation result that  $x(n)$  carry the interpolation of L times and the sample frequency of  $y(n)$  is  $L * f_s$ .

According to the sample theorem, digital signal  $y(n)$  contains all information of analog signal  $x(t)$ . If we hope reconstruct  $x(t)$  from  $y(n)$  perfect, we can let

$$g(t) = \frac{\sin(\pi * f_s * t)}{\pi * f_s * t} \quad (1)$$

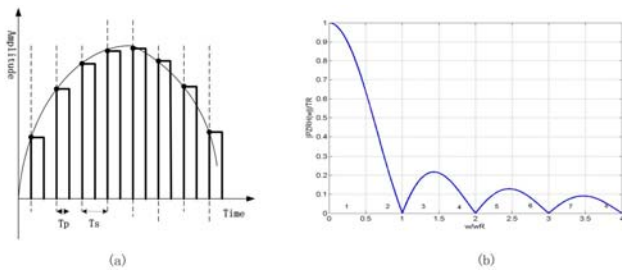

Fig. 2. General wave of DAC output

$$x(t) = \sum_{n=-\infty}^{\infty} y(n) * g(t - nT_s) \quad (2)$$

But it is very hard to build an analog circuit that does this. The most practical way of reconstructing the continuous time signal is to simply “hold” the discrete time values that is continued either for full period  $T_s$  or a fraction  $T_p$ . It is illustrated in Fig.2.(a) is the general wave of DAC output.

The process of “hold” can be realized through an analog circuit that we can call it switch whose function is the reconstructing. Consider the general case with a rectangular pulse  $0 < T_p < T_s$ , let the rectangular unit pulse is  $h(t) = u(t) - u(t - T_p)$ , the time domain signal follows from convolving the Dirac sequence with it. when  $T_p = T_s$ , the spectrum of  $h(t)$  is illustrated in Fig.2.(b). From the figure, we can get when  $w = nw_r (n \in \mathbb{Z}, n \neq 0)$ , the sample function have zero point and the envelope of function drop at the speed of -20dB/Decade or -6dB/Octant. The number 1 to 8 is the Nyquist zone, the Nyquist frequency is  $wR/2$  and the spectrum is the most strong at 1 Nyquist zone at which the normal DAC work and is the baseband zone. the amplitude of other zones spectrum is force to get more decreased. Because of

$$x(t) = \sum_{n=-\infty}^{\infty} y(n) * h(t - nT_s) \quad (3)$$

$$Hp(f) = T_p \frac{\sin(\pi * f * T_p)}{\pi * f * T_p} e^{-j\pi * f * T_p} \quad (4)$$

then

$$Xp(f) = \frac{T_p}{T_s} \frac{\sin(\pi * f * T_p)}{\pi * f * T_p} e^{-j\pi * f * T_p} \sum_{n=-\infty}^{\infty} X(f - \frac{n}{T_s}) \quad (5)$$

As to a discrete signal  $y(n)$ , the spectrum  $Xp(f)$  is periodicity spread of spectrum  $X(f)$  which is Fourier transform of  $x(t)$ . So, when we reconstruct the  $x(t)$  from  $y(n)$ , in frequency domain the reconstruction function  $Hp(f)$  which we select filter the  $Xd(f)$ .

Because the input signal is  $x(n)$ , and the  $y(n)$  is just the result of the interpolation, so the interpolation results can be the perfect embodiment of the different by analyzing the different switching function.

As follow, we will design different interpolation methods and analysis their corresponding switching function to fulfill the reconstruction and upconversion of DAC.

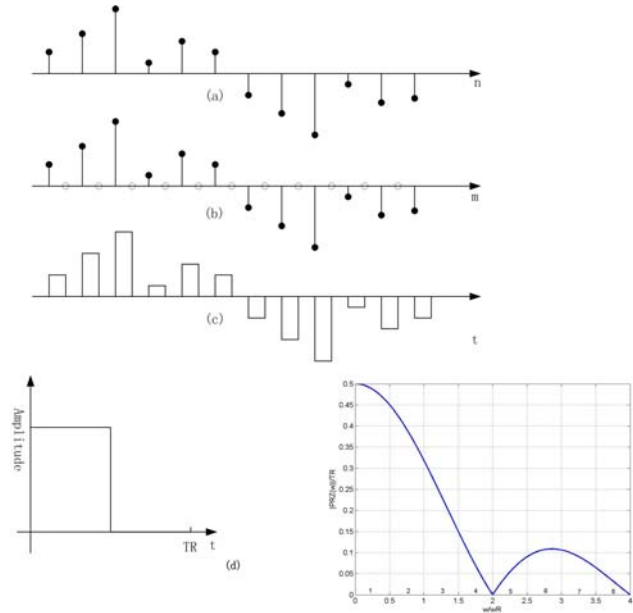

Fig. 3. The result of one zero interpolation. (a) is the wave of input signal  $x(n)$ . (b) is the wave of interpolation  $y(n)$ . (c) is the reconstruction result of  $x(n)$ . (d) is the wave about the time and frequency domain of the switch function

#### A. One Zero Interpolation

One zero interpolation is that insert a zero between each adjacent two points of  $x(n)$ ,so

$$y(n) = \begin{cases} x(n/L) & n = 0, 2, 4, \dots \\ 0 & \text{others} \end{cases} \quad (6)$$

from the Fig.3.(b), we can get the switch function of one zero interpolation is

$$P_{ZRH}(t) = \prod_{(0, \frac{T_R}{2})}^1 (t) = \begin{cases} 1 & 0 < t < \frac{T_R}{2} \\ 0 & t < 0 \text{ or } t > \frac{T_R}{2} \end{cases} \quad (7)$$

then

$$P_{ZRH}(t) = \prod_{(0, \frac{T_R}{2})}^1 (t) = u(t) - u(t - \frac{T_R}{2}) \quad (8)$$

$$P_{ZRH}(w) = \frac{T_R}{2} Sa(w \frac{T_R}{4}) e^{-jw \frac{T_R}{4}} \quad (9)$$

From the spectrum of the switch function of one zero interpolation Fig.3.(d), we can see that the width of it increase to double times more than the spectrum of switch function with “ $T_p=T_s$ ” meanwhile the amplitude decrease to one half. So the spectrum amplitude of first Nyquist zone is restrained but the second and third zone is strengthened relative to the  $P_{ZRH}(w)$ .

#### B. One Complementary Code Interpolation

One complementary code interpolation is that insert a complementary code between each adjacent two points of  $x(n)$ ,so

$$y(n) = \begin{cases} -x(n/L) & n = 0, 2, 4, \dots \\ x(n) & \text{others} \end{cases} \quad (10)$$

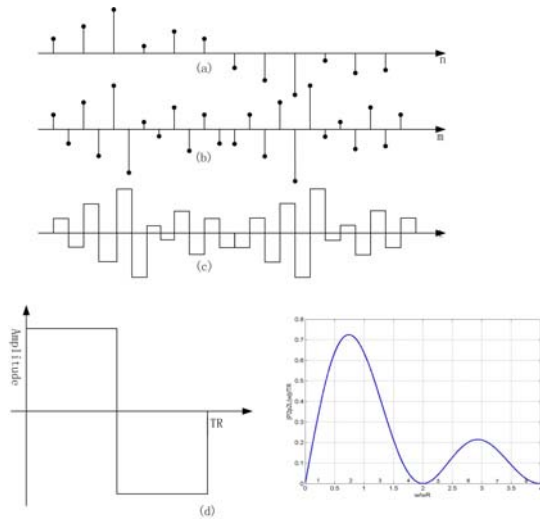

Fig. 4. The result of one complementary code interpolation. (a) is the wave of input signal  $x(n)$ . (b) is the wave of interpolation  $y(n)$ . (c) is the reconstruction result of  $x(n)$ . (d) is the wave about the time and frequency domain of the switch function

from the Fig.4.(d), we can get the switch function of one complementary code interpolation is

$$P_{2p2L}(t) = \prod_{(0, \frac{T_R}{2})} 1(t) - \prod_{(\frac{T_R}{2}, T_R)} 1(t) = \begin{cases} 1 & 0 < t < \frac{T_R}{2} \\ -1 & \frac{T_R}{2} < t < T_R \\ 0 & \text{others} \end{cases} \quad (11)$$

then

$$P_{2p2L}(t) = u(t) - 2u(t - \frac{T_R}{2}) + u(t - T_R) \quad (12)$$

the wave of time domain is Fig.4.(d), Fourier transform

$$P_{2p2L}(w) = T_R Sa(\pi \frac{w}{2w_R}) \sin(\pi \frac{w}{2w_R}) e^{j\frac{\pi}{2} - jw \frac{T_R}{4}} \quad (13)$$

$$|P_{2p2L}(w)| = T_R \sin^2(\theta) \quad (14)$$

here, let  $\theta = \pi \frac{w}{2w_R}$ ,  $\frac{d(\sin^2(\theta))}{d\theta} |_{\theta = \theta_0}$  then we can get when

$$\theta_0 = \pi \frac{w}{2w_R} \approx 1.1655, |P_{2p2L}(w_0)| = 0.7264 T_R \quad (15)$$

So the spectrum in Fig.4.(d) absolutely restrains the DC signal and restrain the first Nyquist zone spectrum in a large degree, but strengthen the second and third Nyquist zone spectrum especially the second Nyquist zone spectrum is strengthened smoothly. To DAC, the realization can be called upconversion.

### C. Alternative Code Interpolation

In every conversion clock, which alternative code interpolation is that insert a complementary code in the first quarter cycle and third quarter cycle meanwhile keep initial code in the second quarter cycle. so

$$y(n) = \begin{cases} -x(n/L) & n = 1, 3, 5, \dots \\ x(n) & n = 2, 6, 10, \dots \\ x(n) & \text{others} \end{cases} \quad (16)$$

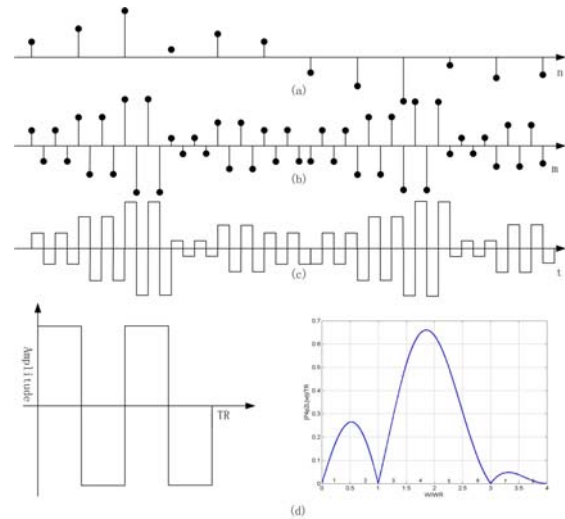

Fig. 5. The result alternative code interpolation. (a) is the wave of input signal  $x(n)$ . (b) is the wave of interpolation  $y(n)$ . (c) is the reconstruction result of  $x(n)$ . (d) is the wave about the time and frequency domain of the switch function

from the Fig.5.(d), we can get the switch function of one zero interpolation is

$$P_{4p2L}(t) = u(t) - 2u(t - \frac{T_R}{4}) + 2u(t - \frac{T_R}{2}) - 2u(t - 3\frac{T_R}{4}) + u(t - T_R) \quad (17)$$

Fourier transform

$$P_{4p2L}(w) = T_R Sa(\pi \frac{w}{4w_R}) \sin(\pi \frac{w}{4w_R}) \cos(\pi \frac{w}{2w_R}) \psi \quad (18)$$

here,  $\psi = e^{j\frac{\pi}{2} - jw \frac{T_R}{2}}$ , the spectrum of switch function is Fig.5.(d) and strengthens the fourth and fifth Nyquist zone amplitude spectrum. So it can realize the function of upconversion higher.

## III. THE CONTROL CIRCUIT ABOUT PRODUCTION OF CODES

The segmentation module divides the digital input data  $x(n)$  into binary weighted codes and thermometer codes to minimize the glitch energy, reduce thermal dependency, and improve the linearity. Generally, the internal expansion module generates an internal expansion code that may be dependent or independent of the data input signal which contain the null code generator and the complementary code generator.

### A. Adjust Duty Cycle

Each generator includes the module about adjusting the duty cycle which is made of some D triggers. The D triggers whose initial state is difference, the output signal of one trigger D1 whose initial state is 1 is connected with the input signal of one trigger D0 whose initial state is 0. We select the number of D1 or D0 base on the duty cycle that we need, it is illustrated in Fig.6, (a) is the circuit and wave about duty cycle of 50 percent. (b) is the circuit and wave about duty cycle of one third. (c) is the circuit and wave about duty cycle of 25 percent.

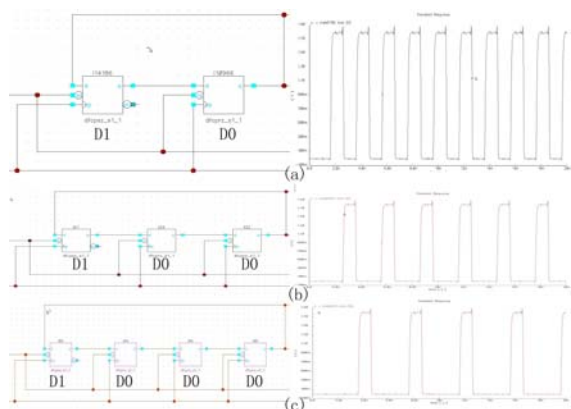

Fig. 6. The circuit and wave of three duty cycles (a) is the circuit and wave about duty cycle of 50 percent. (b) is the circuit and wave about duty cycle of one third. (c) is the circuit and wave about duty cycle of 25 percent

### B. Production of Null Code

The two output signals of the segmentation and the module of adjusting width of clock carry on the “AND” operation. In one conversion clock, what inserting a zero needs is duty cycle of 50 percent. If  $G1 = 0$ , then  $G2$  is connected to  $G1$ , the differential output ( $I_p - I_n$ ) is 0, If  $G1 = 1$ , then  $G2$  is connected to  $\bar{G}1$ , the differential output ( $I_p - I_n$ ) is 1.

### C. Production of Complementary Code

The two output signals of the segmentation and the module of adjusting width of clock carry on the “AND” operation. In one conversion clock, what inserting a complementary needs is duty cycle of 50 percent. Because we will insert the complementary in the first and third quarter cycle, in the second quarter cycle keep the initial state, so the output signal of adjusting duty cycle module is 1010 in each quarter cycle. If  $z = 0$ , then  $G3$  is connected to  $y1$ ,  $G4$  is connected to  $\bar{y}1$  the differential output ( $I_p - I_n$ ) is 1, If  $z = 1$ , then  $G3$  is connected to  $\bar{y}1$ ,  $G4$  is connected to  $y1$  the differential output ( $I_p - I_n$ ) is -1.

## IV. EXPERIMENTAL RESULTS

The Matlab simulation result of DOC is illustrate from fig.15 to fig.20. The input signal is the digital sinusoidal

$$f(n) = \sin(\pi * 10^5 * n) + 2$$

whose frequency is 100Khz and the resolution is 10 bit. A 2048 point FFT is calculated based on the output signal. In Fig.7, the normal state, (a) is wave of the time domain and we can see that the first Nyquist zone spectrum is strengthened from frequency spectrum (b). In Fig.7, one zero interpolation, (c) is wave of the time domain and we can see that the second and third Nyquist zone spectrum is strengthened from frequency spectrum (d) meanwhile the first Nyquist zone spectrum is decrease one half, so the spectrum is modulated the second and third Nyquist zone. In the Fig.7, one complementary code interpolation, (e) is wave of the time domain and we can see that the spectrum (f) is restrained the first Nyquist zone spectrum in a large degree, but strengths the second and

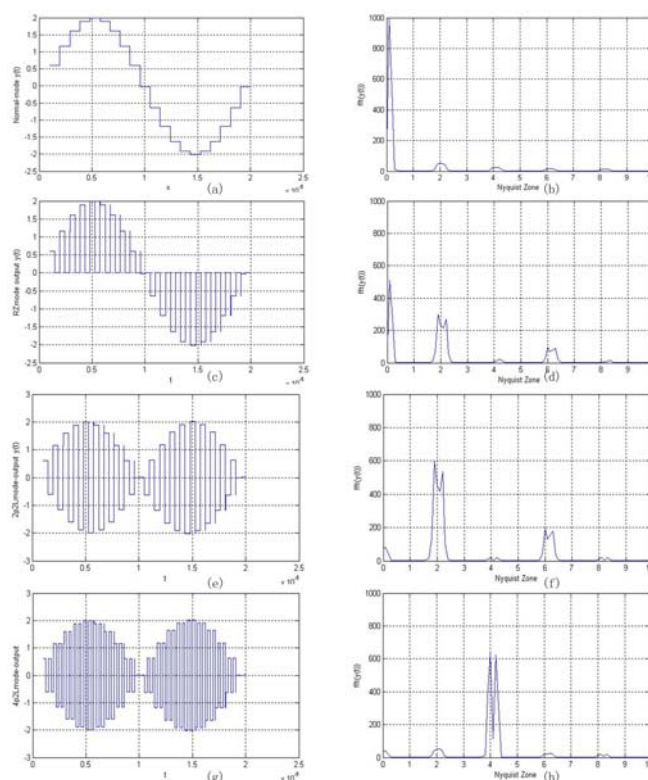

Fig. 7. The time and frequency domain wave of five modes (a)The time domain output of Normal state. (b)The Fourier transform result of Normal state. (c)The time domain output of one zero interpolation. (d)The Fourier transform result of one zero interpolation. (e)The time domain output of one complementary code interpolation. (f)The Fourier transform result of one complementary code interpolation. (g)The time domain output of alternative code interpolation. (h)The Fourier transform result of alternative code interpolation.

third Nyquist zone spectrum, so the spectrum is modulated the second and third Nyquist zone. In Fig.7, alternative code interpolation, (g) is wave of the time domain and we can see that the spectrum (h) mainly strengthens the fourth and fifth Nyquist zone thus can realize the more high upconversion.

## V. CONCLUSION

A novel interpolation scheme for extend usable spectrum is realized to upconversion is proposed. Through the designed circuit, it can make the DAC worked at five modes whose functions are modulator and we can select anyone to achieve the upconversion of the output signal.

## ACKNOWLEDGMENT

The research was supported by Beijing Microelectronics Technology Institute.

## REFERENCES

- [1] A. V. den Bosch, M. A. F. Borremans, M. S. J. Steyaert, and W. Sansen, A 10-bit 1-GSample/s Nyquist Current-Steering CMOS D/A Converter, *IEEE J. Solid-State Circuits* vol. 36, no. 3, 2001, pp. 315–324.
- [2] G. A. M. V. der Plas, J. Vandenbussche, W. Sansen, M. S. J. Steyaert, and G. G. E. Gielen, A 14-bit Intrinsic Accuracy Q2 Random Walk CMOS DAC, *IEEE J. Solid-State Circuits* vol. 34, no. 12, 1999, pp. 1708–1718.

- [3] C.-H. Lin, F. M. der Goes, J. R. Westra, J. Mulder, Y. Lin, E. Arslan, E. Ayranci, X. dong Liu, and K. Bult, A 12 bit 2.9GS/s DAC With IM3-60dBc Beyond 1 GHz in 65nm CMOS, *IEEE J. Solid-State Circuits* vol. 44, no. 12, 2009, pp. 3285–3293.
- [4] D. A. Mercer, LOW POWER APPROACHES TO HIGH SPEED CMOS CURRENT STEERING DACS, *IEEE Custom Intergrated Circuits Conference* 2006, pp. 153–160.