

Theoretical Investigations on Different Casing and Rotor Diameters Ratio to Optimize Shaft Output of a Vaned Type Air Turbine

Bharat Raj Singh and Onkar Singh

Abstract—This paper details a new concept of using compressed air as a potential zero pollution power source for motorbikes. In place of an internal combustion engine, the motorbike is equipped with an air turbine transforms the energy of the compressed air into shaft work. The mathematical modeling and performance evaluation of a small capacity compressed air driven vaned type novel air turbine is presented in this paper. The effect of isobaric admission and adiabatic expansion of high pressure air for different rotor diameters, casing diameters and ratio of rotor to casing diameters of the turbine have been considered and analyzed. It is concluded that the work output is found optimum for some typical values of rotor / casing diameter ratios. In this study, the maximum power works out to 3.825 kW (5.20 HP) for casing diameter of 200 mm and rotor to casing diameter ratio of 0.65 to 0.60 which is sufficient to run motorbike.

Keywords—zero pollution, compressed air, air turbine, injection angle, rotor / casing diameter ratio.

I. INTRODUCTION

WORLDWIDE increasing demand of transport vehicles have resulted in progressively huge quantities of consumptions of fossil fuel and hence causing fast depletion to energy resources. A noted Geophysicist Marion King Hubbert [1] was the first man who applied effectively the principles of geology, physics and mathematics in 1956 for the future projection of oil production from the US reserve base. Hubbert indicated that conventional crude-oil production would attain Peak Oil in 1970 and thereafter start depleting. This may cause serious threat to mankind within 40 years i.e. by 1995. This will also affect environment due to release of huge quantities of pollutant in the atmosphere. Aleklett K. and Campbell C.J., [2] indicated in 2003 that the world is depleting its resources of oil and gas at such a rate that oil production is set to peak and begin to decline by around 2010. This apprehension necessitates the search for environment friendly alternative to fossil fuel oil, or some method of conserving natural resources using non-conventional options, such as bio diesel, wind power, photo voltaic cells etc. and or some energy conversion

Bharat Raj Singh is Professor and Head of Department of Mechanical Engineering, with Sagar Institute of Technology & Management, Barabanki-225001, UP, India (phone: +91-524-822-0001; fax: +91-524-822-0003; e-mail: brsinghko@yahoo.com).

Onkar Singh is Professor and Head of Department of Mechanical Engineering, with Harcourt Butler Technological Institute, Nawabganj, Kanpur-208002, UP, India. (e-mail: onkpar@rediffmail.com).

systems like battery storage, hydrogen cell, compressed air etc to obtain shaft work for the engines of vehicles [3-9].

Compressed air has enormous potential as an alternative to these issues due to its zero pollutant capability and for running prime mover like air turbine. Pioneering work in the area of compressed air engine has been done by French technologist Guy Negre [10] and also by an inventor of quasi turbine G. Saint Hilaire [11]. Use of compressed air as working fluid offers a prime mover which does not involve combustion process for producing shaft work. Thus, the great advantages in terms of free availability of air as fuel and the emissions free from carbon dioxide, carbon monoxide and nitrous oxides is apparent from such air motors. Compressed air driven prime movers are also found to be cost effective compared to fossil fuel driven engines. It only has perennial compressed air requirement which needs some source of energy for running compressor whose overall analysis shows that the compressed air system is quite attractive option for light vehicle applications [12]. In view of these attractive features, the compressed air engine may become the dominant technology in place of the electric and hydrogen cell vehicle markets. Some studies [13-21] for optimizing the efficiency of various types of turbines have also been done.

This paper focuses on the study of influence of rotor / casing dimension on the performance of air turbine being proposed for motorbikes. In place of an internal combustion engine, the motorbike is proposed to be equipped with an air turbine, which transforms the energy of the compressed air into shaft work for running the vehicle. The mathematical modeling and performance evaluation of a small capacity compressed air driven vaned type novel air turbine is presented here. The effect of isobaric admission and adiabatic expansion of high pressure air for different rotor diameters, casing diameters and rotor / casing diameter ratios (d/D) of the turbine have been considered and analyzed.

II. VANED TYPE AIR TURBINE

A vaned type air turbine as shown in Figure 1a has been considered. Proposed air turbine is considered to work on the reverse of working principle of vane type compressor. In this arrangement total shaft work is cumulative effect of isobaric admission of compressed air jet on vanes and the adiabatic expansion of high pressure air. In earlier study conducted by authors a prototype of air turbine was developed and its functionality was ensured [12]. Vanes of novel air turbine

were placed under spring loading to maintain their regular contact with the casing wall to minimize leakage.

The present objective is to investigate the performance of an air turbine with the variation of rotor / casing dimensions. The air turbine considered has capability to yield output of 5.50 to 6.80 HP at 4-6 bar air pressure and for speed of 2000–2500 rpm, which is suitable for a motorbike. A cylinder for the storage of compressed air with a minimum capacity of storing air for the requirement of 30 min running at initial stage and maximum pressure of 20 bar is used as a source of compressed air.

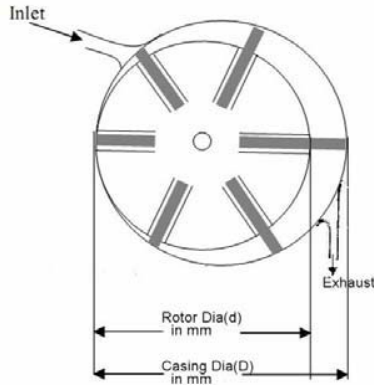

Fig.1a Air Turbine-Schematic Drawing

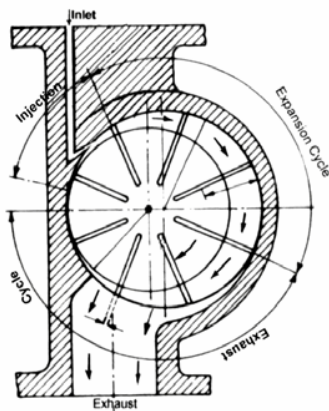

Fig.1b Air Turbine- Model

III. MATHEMATICAL MODELING

The high pressure jet of air at ambient temperature drives the rotor in novel air turbine due to both isobaric admission and adiabatic expansion. Such high pressure air when enters through the inlet passage, pushes the vane for producing rotational movement through this vane and thereafter air so collected between two consecutive vanes of the rotor is gradually expanded up to exit passage. This isobaric admission and adiabatic expansion of high pressure air both contribute in producing the shaft work from air turbine. Compressed air leaving the air turbine after expansion is sent out from the exit passage. It is assumed that the scavenging of the rotor is perfect and the work involved in recompression of the residual air is absent.

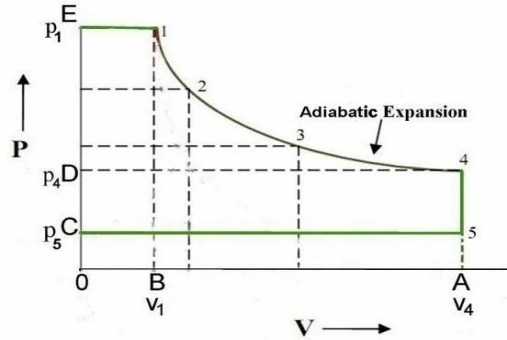

Fig. 2 Thermodynamic Processes (Isobaric, adiabatic and Isochoric Expansion)

From Figure 2, it is seen that work output is due to isobaric admission (E to 1), adiabatic expansion (1 to 4) and steady exit flow work (4 to 5). Thus, total work done due to thermodynamic process may be written as:

$$[\text{Area under (E145CE)}] = [\text{Area under (E1BOE)}] + [\text{Area under (14AB1)}] - [\text{Area under (4AOD4)}] + [\text{Steady Flow (45CD4)}]$$

$$\text{Total Work output} = [\text{Thermodynamic expansion work (} w_1 \text{)}] + [\text{Exit steady flow work (} w_2 \text{)}]$$

$$w = [(w_1) + (w_2)] \quad (1)$$

From the above eq. (1) thermodynamic expansion work can be written as

$$w_1 = p_1 \cdot v_1 + \left(\frac{p_1 \cdot v_1 - p_4 \cdot v_4}{\gamma - 1} \right) - p_4 \cdot v_4 \quad \text{or}$$

$$w_1 = \left[\left(\frac{\gamma}{\gamma - 1} \right) \cdot (p_1 \cdot v_1 - p_4 \cdot v_4) \right]$$

For adiabatic process, $p \cdot v^\gamma = p_1 \cdot v_1^\gamma = p_4 \cdot v_4^\gamma$ or

$$v_4 = \left(\frac{p_1}{p_4} \right)^{\frac{1}{\gamma}} \cdot v_1$$

Thus thermodynamic expansion work output can be written as

$$w_1 = \left(\frac{\gamma}{\gamma - 1} \right) \cdot p_1 \cdot v_1 \cdot \left\{ 1 - \left(\frac{p_4}{p_1} \right)^{\frac{\gamma - 1}{\gamma}} \right\} \quad (2)$$

From the above eq. (1) steady flow work can be written as

$$w_2 = \int_4^5 v \cdot dp = (p \cdot v_4 - p_5 \cdot v_5) \quad (3)$$

After the expansion process during exit flow the pressure p_4 cannot fall below atmospheric pressure p_5 . Thus, from eq. (1) the net work output will be:

$$w = (w_1 + w_2) = \left(\frac{\gamma}{\gamma - 1} \right) \cdot p_1 \cdot v_1 \cdot \left\{ 1 - \left(\frac{p_4}{p_1} \right)^{\frac{\gamma - 1}{\gamma}} \right\} + (p_4 - p_5) \cdot v_4 \quad (4)$$

When air turbine is having n number of vanes, then shaft output [22] can be written as,

$$w_n = n \cdot \left(\frac{\gamma}{\gamma - 1} \right) \cdot p_1 \cdot v_1 \cdot \left\{ 1 - \left(\frac{p_4}{p_1} \right)^{\frac{\gamma - 1}{\gamma}} \right\} + n \cdot (p_4 - p_5) \cdot v_4 \quad (5)$$

Where w_n is work output (in Nm), for complete one cycle.

Therefore, the total power output (work done per unit time) W for speed of rotation N rpm will be mentioned as:

$$W_{total} = n \cdot (N / 60) \cdot \left(\frac{\gamma}{\gamma - 1} \right) \cdot p_1 \cdot v_1 \cdot \left\{ 1 - \left(\frac{p_4}{p_1} \right)^{\frac{\gamma - 1}{\gamma}} \right\} + n \cdot (N / 60) \cdot (p_4 - p_5) \cdot v_4 \quad (6)$$

Where $w_{exp} = n \cdot (N / 60) \cdot \left(\frac{\gamma}{\gamma - 1} \right) \cdot p_1 \cdot v_1 \cdot \left\{ 1 - \left(\frac{p_4}{p_1} \right)^{\frac{\gamma - 1}{\gamma}} \right\}$

and $w_{flow} = n \cdot (N / 60) \cdot (p_4 - p_5) \cdot v_4$

Figure 1 shows that if vanes are at angular spacing of θ degree, then total number of vanes will be $n = (360/\theta)$. The variation in volume during expansion from inlet to exit (i.e. v_1 to v_4) can be derived by the variable extended length of vane as shown in Figure 3 at every point of movement between two consecutive vanes.

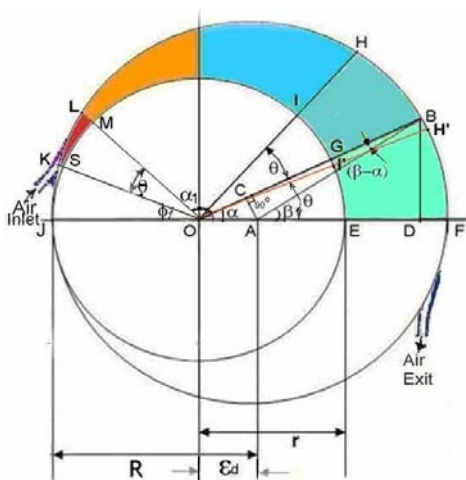

Fig. 3 Variable length BG and IH and injection angle ϕ

From Figure 3, it is seen that when two consecutive vanes at OK and OL moves to position OH and OB, the extended vane lengths varies from SK to IH and LM to BG, thus the variable length BG at variable α_i is assumed as $X_{at'variable'\alpha}$ can be written from the geometry:

$$BG = x_{at,variable'\alpha} = (1/2) \cdot D \cdot \cos \left[\sin^{-1} \left\{ \left(\frac{D-d}{D} \right) \cdot \sin \alpha \right\} \right] + (1/2) \cdot (D-d) \cdot \cos \alpha - d/2 \quad (7)$$

Where D is diameter of casing and d is diameter of rotor, α is angle $\angle BOF$, β is angle $\angle BAF$ and θ is angle $\angle HOB$ or $\angle KOL$, between two consecutive vanes and ϕ is angle $\angle KOJ$ at which injection pressure enters the air turbine.

Variable volume of cuboid B-G-I-H-B can be written as:

$$v_{cuboids} = L \cdot \left\{ \frac{(X_{1i} + X_{2i})(d + X_{1i})}{4} \right\} \cdot \sin \theta \quad (8)$$

Where $BG = X_{1i}$ and $IH = X_{2i}$ variable length of vanes as shown in Figure 3.

The volume at inlet v_1 or v_{min} will fall between angle $\angle LOF = \alpha_{1min} = (180 - \theta - \phi)$ and angle $\angle KOF = \alpha_{2min} = (\alpha_{1min} + \theta) = (180 - \phi)$ as seen in Fig. 3, when air is injected at angle ϕ into turbine

Applying above conditions into equations (7), then $LM = X_{1min}$ and $SK = X_{2min}$ can be written as:

$$X_{1min} = \frac{D}{2} \cdot \cos \left[\sin^{-1} \left\{ \left(\frac{D-d}{D} \right) \cdot \sin(180 - \theta - \phi) \right\} \right] + \left[\left(\frac{D-d}{2} \right) \cdot \cos(180 - \theta - \phi) - \frac{d}{2} \right] \quad (9)$$

$$X_{2min} = \left(\frac{D}{2} \right) \cdot \cos \left[\sin^{-1} \left\{ \left(\frac{D-d}{D} \right) \cdot \sin(180 - \phi) \right\} \right] + \left[\left(\frac{D-d}{2} \right) \cdot \cos(180 - \phi) - \frac{d}{2} \right] \quad (10)$$

Applying values of X_{1min} and X_{2min} to equation (8),

$$v_1 = v_{min} = L \cdot \left\{ \frac{(X_{1min} + X_{2min})(d + X_{1min})}{4} \right\} \cdot \sin \theta \quad (11)$$

The Volume at exit v_4 or v_{max} will fall between angle $\angle BOF$ $\alpha_{1max} = \alpha = 0$ and angle $\angle HOF$ $\alpha_{2max} = (\alpha_{1max} + \theta) = \theta$

Applying above conditions into equations (7), then $FE = X_{1max} =$ Corresponding to BG at $\alpha = 0$ degree and $I'H' = X_{2max} =$ Corresponding IH at $(\alpha + \theta) = \theta$ degree can be written as:

$$X_{1\max} = (D - d) \quad (12)$$

$$X_{2\max} = \left(\frac{D}{2}\right) \cos \left[\sin^{-1} \left\{ \left(\frac{D-d}{D}\right) \sin \theta \right\} \right] + \left\{ \left(\frac{D-d}{2}\right) \cos \theta \right\} - \frac{d}{2} \quad (13)$$

Applying values of $X_{1\max}$ and $X_{2\max}$ to equation (8),

$$v_4 = v_{\max} = L \cdot \left\{ \frac{(X_{1\max} + X_{2\max})(d + X_{1\max})}{4} \right\} \cdot \sin \theta \quad (14)$$

Applying values of v_1 and v_4 from equations (11) and (14) to equation (6), the total power output available W_{total} , can be written as:

$$W_{total} = n(N/60) \cdot \left(\frac{\gamma}{\gamma-1}\right) \cdot \left[1 - \left(\frac{p_4}{p_1}\right)^{\frac{\gamma-1}{\gamma}} \right] \cdot p_1 \cdot \left[L \cdot \left\{ \frac{(X_{1\max} + X_{2\max})(d + X_{1\max})}{4} \right\} \cdot \sin \theta \right] + n(N/60) \cdot (p_4 - p_5) \cdot \left[L \cdot \left\{ \frac{(X_{1\max} + X_{2\max})(d + X_{1\max})}{4} \right\} \cdot \sin \theta \right] \quad (15)$$

IV. ASSUMPTION AND INVESTIGATION PARAMETERS

Various input parameters are considered and listed in Table-1 for investigation of effect of rotor / casing diameter ratio and its optimization. It is assumed that rotor will have 10 numbers of vanes and hence angle between two consecutive vanes would be 36°. It is also considered that high pressure air (2-6 bar) will enter into two consecutive rotor vanes at an angle 22.5°, that is less than the 2/3rd of vane angle 36° (≈24°). Rotor to casing diameter ratios for study was considered from 0.95, 0.90, 0.85 to 0.55 for different set of casing diameters 100mm, 150mm and 200mm. Exit air pressure is considered as atmospheric pressure (1.0132 bar) and rotor length also assumed as 35mm for this study.

TABLE 1
 INPUT PARAMETERS

Symbols	Parameters
Ratio of Rotor to Casing diameter (d/D)	0.95, 0.9, 0.85, 0.80, 0.75, 0.70, 0.65, 0.60 and 0.55 when casing Diameters are kept D=100 mm, 150 mm and 200 mm
p_1	2 bar(≈30 psi), 3 bar(≈45psi), 4bar(≈60psi), 5bar(≈75psi), 6bar(≈90psi) –inlet pressures
p_5	1.0132 bar- exit pressure
p_4	*1.0 to 1.1 $p_5 = 1.05$ bar
N	2500 rpm
L	35mm length of rotor (assumed minimum)
γ	1.4 for air
θ	**36° angle between 2-vanes, (i.e. rotor contains correspondingly 10 number of vanes)
ϕ	**22.5° angle at which compressed air through nozzle enters into rotor

* For optimum output, exit pressure may fall up to atmospheric pressure (i.e. ≈1 bar).

** 36° angle between 2-vanes (assumed) and 22.5° angle at which compressed air through nozzle enters into rotor, for ease of rotation.

V. RESULTS AND DISCUSSION

Various input parameters considered for study are listed in Table 1. Using the mathematical model the effect of speed of rotation, rotor/casing diameter ratio and injection pressure on the expansion power output, flow work output and total power output from air turbine is studied. Here the vane angle θ , injection angle ϕ and speed of rotation N of the air turbine are considered to be constant for whole study. The results obtained have been plotted in Figures 4 to 11, for the rotor/casing diameter ratio (d/D), varied as 0.95, 0.90, 0.85, 0.80, 0.75, 0.65, 0.60 and 0.55 at vane angle of 36°, injection angle of 22.5° at different injection pressures of 30, 45, 60, 75 and 90 psi and at the speed of rotation 2500 rpm.

Figure 4 shows the variation of expansion power at different rotor/casing diameter ratio varied as 0.95, 0.9, 0.85, 0.80, 0.75, 0.70, 0.65, 0.60 and 0.55 at constant vane angle 36°, air injection angle 22.5°, speed of rotations 2500 rpm, different air injection pressure of 2 to 6 bar and at casing diameter of 100mm. It is evident that the shaft power due to expansion at 2 bar is lower at higher rotor/casing diameter ratio of 0.95, thereafter gradually increases at 0.70 to 0.55 and, largest when rotor/casing diameter ratio is kept 0.55. For higher injection pressure 4 to 6 bar, this is attributed to the large work output per time unit in similar pattern. It is evident that there exists optimum rotor/casing diameter for every injection pressure which offers the maximum expansion power. This value of maximum expansion power is more for higher injection pressures compared to lower injection pressures due to large power producing potential in higher injection pressure air. The optimal value of rotor/casing diameter ratio is found to decrease gradually with increasing air injection pressure values. Similar variations are also observed at higher casing diameters 150mm and 200mm but expansion power is higher in comparison to casing diameter 100 mm as evident from Fig.5.

Figure 6 shows the variation of exit flow power at different rotor/casing diameter ratios of 0.95, 0.9, 0.85, 0.80, 0.75, 0.70, 0.65, 0.60 and 0.55 at constant vane angle 36°, air injection angle 22.5°, at speed of rotation 2500 rpm and different air injection pressures between 2 - 6 bar and at casing diameter of 100mm. It is evident that the shaft power due to exit flow work is lowest at 2 bar and linearly increases up to rotor/casing diameter ratio of 0.55. It is quite evident that the shaft power due to exit flow work gradually increases with reducing value of rotor/casing diameter ratio in view of the gap between the rotor and casing as increases gradually. That is why the exit flow power is nearly insignificant for rotor/casing diameter ratio of 0.95 and would be absent when this ratio value is unity. Similar variations are also observed for higher casing diameter 150 mm and 200 mm but exit flow power is much higher (approx. 4 times) for casing diameter 200 mm in comparison to casing diameter 100 mm as seen in Fig.7.

Figure 8 shows the percentage contribution of expansion power against total work output for rotor/casing diameter ratio

varying as 0.95, 0.9, 0.85, 0.80, 0.75, 0.70, 0.65, 0.60 and 0.55 at constant vane angle 36° , air injection angle 22.5° , at speed of rotation 2500 rpm and different air injection pressures between 2-6 bar and at casing diameter of 100mm. It is evident that percentage contribution of expansion power is highest at 6 bar. At 2 bar injection pressure the contribution of expansion power against total power is lowest at all rotor/casing diameter ratios and gradually decreases from 76.80% to 58.48% as rotor/casing diameter ratio decreases from 0.95 to 0.55. Higher contribution of expansion power at higher rotor/casing diameter ratios is attributed to the smaller contribution of shaft power due to exit flow at these dimensions and so the major contribution of work is due to expansion power. The contribution of expansion power is found to follow same trend for injection pressure 4-6 bar but much higher between 95.78% to 87.20% for casing diameter 150 mm and 200 mm (Figures are not shown but similar to Figs. 8, 9).

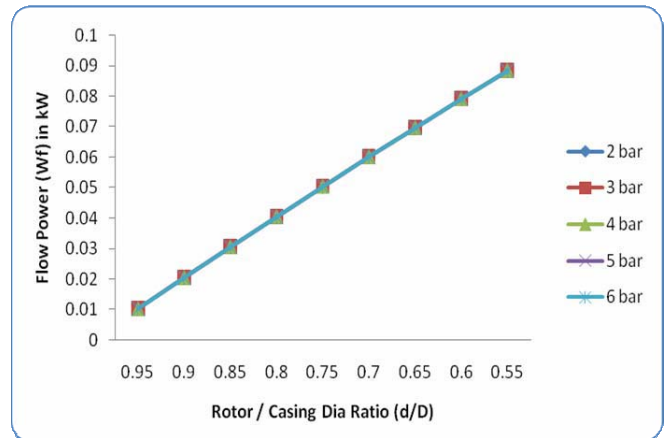

Fig. 6 Exit Flow Power vs. Rotor / Casing Diameter (d/D) Ratio when D= 100 mm

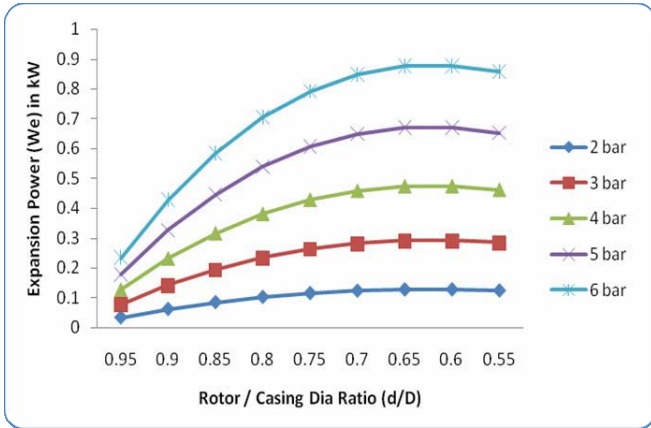

Fig. 4 Expansion Power vs. Rotor / Casing Diameter (d/D) Ratio when D= 100 mm

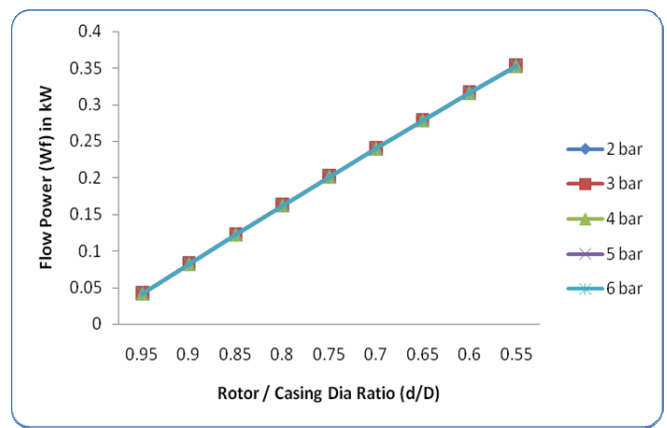

Fig. 7 Exit Flow Power vs. Rotor / Casing Diameter (d/D) Ratio when D= 200 mm

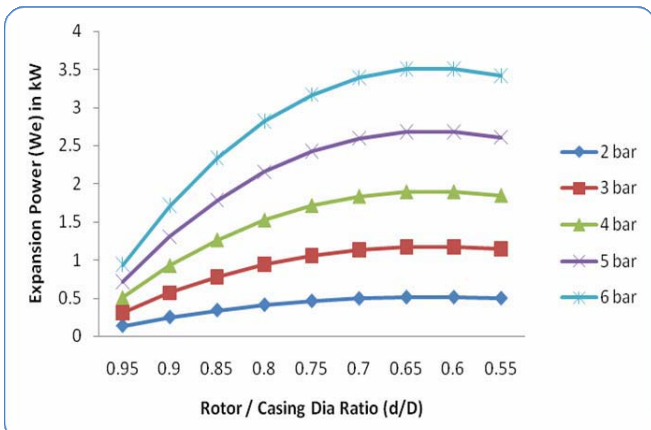

Fig. 5 Expansion Power vs. Rotor / Casing Diameter (d/D) Ratio when D= 200 mm

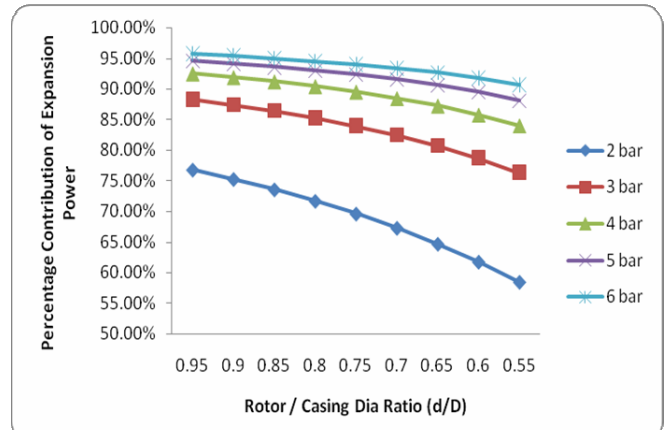

Fig. 8 Percentage Contribution of Expansion power vs. Rotor / Casing Diameter (d/D) Ratio when D= 100 mm

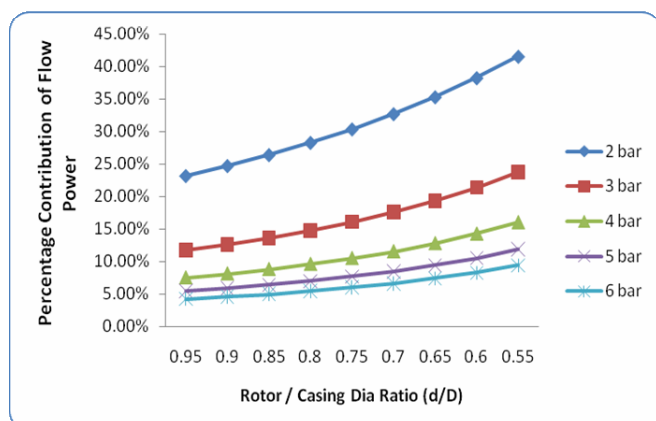

Fig. 9 Percentage Contribution of Exit Flow Power vs. Rotor / Casing Diameter (d/D) Ratio when D= 100mm

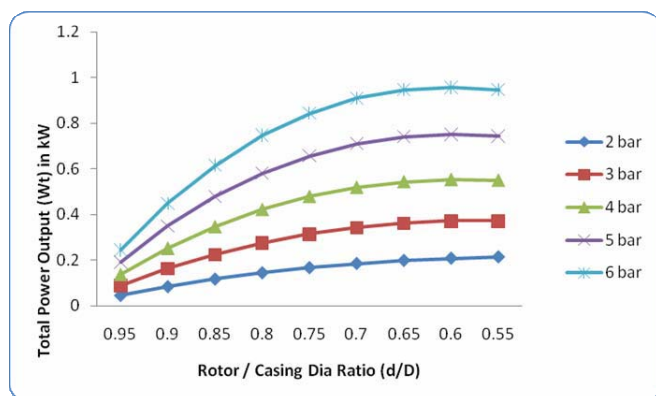

Fig. 10 Total Power output vs. Rotor / Casing Diameter (d/D) Ratio when D= 100 mm

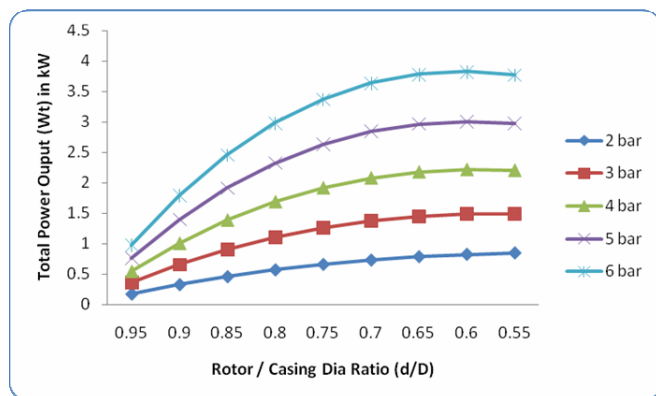

Fig. 11 Total Power output vs. Rotor / Casing Diameter (d/D) Ratio when D= 200 mm

Figure 9 shows the percentage contribution of exit flow power in total power output for varying rotor/casing diameter ratio of 0.95, 0.9, 0.85, 0.80, 0.75, 0.70, 0.65, 0.60 and 0.55 at constant vane angle 36° , air injection angle 22.5° , at speed of rotation 2500 rpm and different air injection pressures between 2 - 6 bar and at casing diameter of 100mm. It is evident that percentage contribution of exit flow power is lower at 2 bar, when rotor/casing diameter ratio is 0.95 and gradually increases from 23.20% to 41.52% as this diameter

ratio drops up to 0.55 when casing diameter is kept 100mm. At further higher injection pressures of 3 to 6 bar the contribution of exit flow power is lowest between 4.22% to 23.71% at bigger rotor/casing diameter ratio and increases as the rotor/casing diameter ratio drops. The contribution of shaft power due to exit flow is exactly found to follow same trend at higher casing diameters 150mm and 200 mm, (Figs. are not shown).

Variation of total power output with respect to rotor/casing diameter ratio of 0.95, 0.9, 0.85, 0.80, 0.75, 0.70, 0.65, 0.60 and 0.55, at constant vane angle of 36° , air injection angle of 22.5° , at speed of rotation 2500 rpm and different air injection pressures between 2 - 6 bar and at casing diameter 100 mm is shown in Figure 10. Total power at 2-3 bar is seen lower at bigger rotor/casing diameter ratio 0.95 and highest when rotor/casing diameter ratio is 0.55. Thereafter maximum total power output is found when the rotor/casing diameter ratio decreases from 0.65 to 0.60 for larger injection pressure of 4 to 6 bar. This behavior of optimum value of rotor/casing diameter ratio is predominantly due to expansion power variation pattern. Similar variations are also observed at higher casing diameter of 150mm and 200mm as shown in Fig. 11.

It is thus observed that in the vane turbine total shaft power output is combined effect of the component of expansion power and exit flow power. The significant contribution of exit flow power due to steady flow in respect to total power output varies from 4.22% to 7.36% for higher injection pressure 6 bar and 23.22% to 35.30% for 2 bar injection pressure at constant injection angle 22.5° , constant vane angle 36° , at speed of rotation 2500 rpm and at casing diameter of 200mm for different rotor/casing diameter ratio of 0.95, 0.9, 0.85, 0.80, 0.75, 0.70, 0.65, 0.60 and 0.55. Thus it is obvious that the expansion power output as well as total power output is found optimum when rotor/casing diameter ratio lies from 0.65 to 0.60 at higher casing diameter and is a deciding factor for desired shaft power output.

VI. CONCLUSION

The results obtained from above investigations based on input parameters such as injection angle, vane angle and speed of rotation are kept 22.5° , 36° and 2500 rpm respectively, following conclusions are drawn:

- There exists an optimal value of rotor/casing diameter ratio (approx. 0.65 to 0.60) for the considered air turbine for all air injection pressures. This optimal value of rotor/casing diameter ratio offers the maximum expansion power from 0.511 kW to 3.509 kW at different injection air pressures varying from 2 to 6 bar.
- The exit flow power due to steady flow is seen to increase linearly for the rotor/casing diameter ratio varying from 0.95 to 0.55.
- Total output power from the air turbine is seen to be maximum for the higher injection air pressure and there exists an optimum value of rotor/casing diameter ratio for all injection pressure 2-6 bar.
 - The maximum power output is seen to be 3.825 kW for injection pressure of 6 bar.

- The optimal value of rotor/casing diameter ratio offers the maximum power output varying from 0.2069 kW to 0.9563 kW at casing diameter of 100 mm, 0.4788 kW to 2.1516 kW at casing diameter of 150mm and 0.8513 kW to 3.8251 kW at casing diameter of 200 mm for injection air pressure varying between 2 to 6 bar.
- The optimal rotor/casing diameter ratio value varies from 0.65 to 0.60 at all casing diameter for 100mm, 150mm and 200 mm at constant speed 2500 rpm and different injection air pressures varying from 2 to 6 bar.

Thus for optimum shaft power output of a novel vaned type air turbine, the design parameters for rotor diameter to casing diameter (d/D) ratio must be kept between 0.60 to 0.65. It is also suggested that vane angle and pressure injection angle have important role for optimizing the power output and hence needs future investigations.

NOMENCLATURE

d	diameter of rotor ($2r$) in meter
D	diameter of outer ($2R$) cylinder in meter
L	length of rotor having vanes in meter
m	meter
n	no. of vanes= $(360/\theta)$
N	no. of revolution per minute
P	pressure in bar
p_1, v_1	pressure and volume respectively at which air strike the Turbine,
p_4, v_4	pressure and volume respectively at which maximum expansion of air takes place,
p_5	pressure at which turbine releases the air to atmosphere.
r	radius of rotor ($d/2$) in meter
R	radius of outer casing ($D/2$) in meter
v	volume in cu-m
w	theoretical work output in Nm
W	theoretical power output (Nm/s)
X_{1i}	variable extended lengths of vane at point 1
X_{2i}	variable extended lengths of vane at point 2
bar	(1 / 1.0132) atmospheric pressure
cu-m	cubic meter
HP	horse power
km	kilo-meter
kW	kilo-watt
Nm	newton meter
rpm	revolution per minute

Subscripts

$1, 2, \dots, 4, 5$	subscripts – indicates the positions of vanes in casing
e, exp	expansion

f, flow	flow
min	minimum
max	maximum
t, total	total

Geek symbols

α	angle BOF
α_1	angle LOF (=180- ϕ)
α_2	angle KOF (=180- θ - ϕ)
β	angle BAF
γ	1.4 for air
θ	angle between 2-vanes(BOH)
ϕ	angle at which compressed air enters into rotor through nozzle
ξ_d	eccentricity ($R-r$)

REFERENCES

- [1] Hubbert M.K., 1956, Nuclear energy and the fossil fuels; Amer. Petrol. Inst. Drilling and Production Practice, Proc. Spring Meeting, San Antonio, Texas. 7-25.[#187].
- [2] Aleklett K. and Campbell C.J., 2003, The Peak and Decline of World Oil and Gas Production- Minerals and Energy, Raw Materials Report, Volume 18, Number 1, 2003, pp. 5-20(16).
- [3] Singh B.R. and Singh Onkar, 2007, Use of Non-Conventional Energy for Sustainability to Fossil Fuel, National Conference on Recent Trend on Mechanical Engineering, RAME-2007, held on 28-29th March'2007 at Baba Sahab Dr. Bhim Rao Ambedkar College of Agricultural Engineering and Technology, Etawah-Proceedings pp 130-136.
- [4] Singh B.R. and Singh Onkar, 2007, Uses of Wind Power as a Non-Conventional / Renewable Energy for Sustainability, National Conference on State of Art Technology in Mechanical Engineering, STEM-2007, held on October 29-31, 2007 at College of Technology, G.B. Pant University, Pant Nagar, UP-Proceedings pp 503-515.
- [5] Honton E. J., 2004, Hydrogen Fuel Cell Car, presented at 15th Annual US Conference and Hydrogen Expo, April'2004, USA.
- [6] Rose Robert and William J. Vincent, 2004, Fuel Cell Vehicle World Survey 2003, Breakthrough Technologies Institute, February' 2004, Washington, D.C.
- [7] Singh B.R. and Singh Onkar, 2006, Necessity and Potential for Bio-Diesel Use in India, International Conference on Bio-Fuel Vision-2015, October'13th -15th, 2006 at Bikaner, India- Proceedings pp 71-89.
- [8] Singh B.R. and Singh Onkar, 2006, Study of Compressed Air as an alternative to fossil fuel for Automobile Engines, International Conference on Challenges and Strategies for Sustainable Energy and Environment- held on 10-11th June'2006 at UPTU, Lucknow, UP-Proceedings pp 179-191.
- [9] Singh B.R. and Singh Onkar, 2008, A Study on Sustainable Energy Sources and its Conversion Systems towards Development of an Efficient Zero Pollution Novel Turbine to be used as Prime-mover to the Light Vehicle, 2008 ASME International Mechanical Engineering Congress and Exposition, held on October 31-November 6, 2008 at Boston, Massachusetts, USA- Paper No. IMECE -2008 -66803.
- [10] Negre Guy and Negre Cyril, 2004, Compressed Air - The Most Sustainable Energy Carrier for Community Vehicles, Speech in front of assembly at Kultur gathered for Fuel Cells World, Tuesday 29th June '2004.
- [11] Saint Hilaire G., Saint Hilaire R. and Saint Hilaire, Y., 2005, Quasiturbine zero pollution car using gasoline. Festival at Le Lundi, Montreal Gazette, 26 September 2005.
- [12] Singh B.R. and Singh Onkar, 2008, Development of a vaned type novel Air Turbine, International Journal of Mechanical Engineering Science (The manuscript was received on 21st December 2007 and was accepted after revision for publication on 03rd June 2008), Proc. IMechE Vol. 222 Part C, pp 1419-1426.

- [13] Knowlen C., Bruckner A. P., Mattick A.T. and Hertzberg A., 1998, High Efficiency Energy Conversion Systems for Liquid Nitrogen Automobiles, Society of Automotive Engineers, Inc., AIAA 98-1898.
- [14] Fuglsang P., Bak C. and Gunna M., 2004, Design and verification of the Ris0-B1 Airfoil-family for Wind Turbines, Journal of Solar Energy Engg., ASME- Nov'2004, Vol.126 pp 1002-1008.
- [15] Gorla R. and Reddy, S., 2005, Probabilistic Heat Transfer and Structural Analysis of Turbine Blade, IJTJE, Vol. 22, pp 1- 11.
- [16] Selig Michel S. and Bryan D. McGranahan, 2004, Wind Tunnel Aerodynamics Tests of Six Airfoils for use on Small Wind Turbines, Journal of Solar Energy Engg., ASME-Nov'2004, Vol.126, pp986-1000.
- [17] Schreck S. and Robinson M., 2004, Tip Speed Ratio Influences on Rationally Augmented Boundary Layer Topology and Aerodynamic Force Generation, Journal of Solar Energy Engg., ASME-Nov' 2004- Vol.126 pp1025-1033.
- [18] Singh B.R. and Singh Onkar, 2008, A concept for Development of a Vaned Type Novel Air Turbine, 12th International Symposium on Transport Phenomena and Dynamics of Rotating Machinery - held on February 17-22, 2008 at Pacific Center of Thermal-Fluids Engineering, Sheraton Mohana Surfriider Hotel Honolulu, Hawaii - Paper No. ISROMAC-12-20046.
- [19] Singh B.R. and Singh Onkar, 2008, Energy Storage System to meet Challenges of 21st Century- an Overview, All India Seminar on Energy Management in Perceptive of Indian Scenario-held on October 17-19, 2008 at Institution of Engineer (India), State Centre, Engineer's Bhawan, Lucknow-Proceedings Chapter15, pp 157-167.
- [20] Singh B.R. and Singh Onkar, 2008, A Study to Optimize the Output of Vaned Type Novel Air Turbine, 4th International Conference on Energy Research and Development, held on 17-19 November, 2008 at State of Kuwait, Kuwait- Paper No. ICERD - 4 -1353.
- [21] Singh B.R. and Singh Onkar, 2008, Parametric Evaluation of Vane Angle on performance of Novel Air Turbine, Journal of Science, Engineering and Management, SITM , December, 2008, Vol. 2, pp 7-18.
- [22] Singh Onkar, 2009, Reciprocating and Rotary Compressor, Applied Thermodynamics, New Age International (P) Ltd., Publishers, India, ISBN: 978-81-224-2583-3, Feb2009, pp797-798.