

Comparison of Full Graph Methods of Switched Circuits Solution

Zdeňka Dostálová, David Matoušek, Bohumil Brtník,

Abstract—As there are also graph methods of circuit analysis in addition to algebraic methods, it is, in theory, clearly possible to carry out an analysis of a whole switched circuit in two-phase switching exclusively by the graph method as well. This article deals with two methods of full-graph solving of switched circuits: by transformation graphs and by two-graphs. It deals with the circuit switched capacitors and the switched current, too. All methods are presented in an equally detailed steps to be able to compare.

Keywords— Switched capacitors of two phases, switched currents of two phases, transformation graph, two-graph, Mason's formula, voltage transfer, summary graph.

I. INTRODUCTION

ANALYSING electric circuits is necessary not only for computing of circuit properties but also for understanding their principles. Computer methods are a powerful tool for symbolic analysis of circuit parameters [1], [5]. But it is advantageous to have a tool capable of clear and simple symbolic analysis, too. Graph methods can be considered this tool. Thanks to its clarity, a graphic method is extremely suitable even for understanding of these networks. A clearly arranged set of transformation graphs derived for different types of switching circuits can be used for analyzing capacitor switched networks and of course for understanding them, too. The M-C signal flow graphs are used to design [1] and analyze [2] continuous time circuits and periodically switched linear circuits, too.

II. SOLUTION OF SWITCHED CAPACITOR CIRCUITS

A circuit with a switched capacitor has got the schematic wiring diagram shown in Fig.1.

The circuit has five nodes; two switched capacitors C_1 and C_3 , capacitor C_2 and an ideal operational amplifier. We will show two methods of solving: a solution based on a transformation graph and a solution based on two-graphs.

A. Solving Based on Transformation Graphs

The circuit has five nodes; therefore the starting graph of the circuit in Fig.2 has also five nodes.

Z. Dostálová is with College of Polytechnics Jihlava, Czech Republic, (phone: 420 567 141 111, fax: 420 567 300 727; e-mail: dostalova@vospj.cz).

D. Matoušek is with the College of Polytechnics Jihlava, Czech Republic, (phone: 420 567 141 119, fax: 420 567 300 727; e-mail: matousek@vospj.cz).

B. Brtník is with College of Polytechnics Jihlava, Czech Republic, (phone: 420 567 141 119, fax: 420 567 300 727; e-mail: brtnik@vospj.cz).

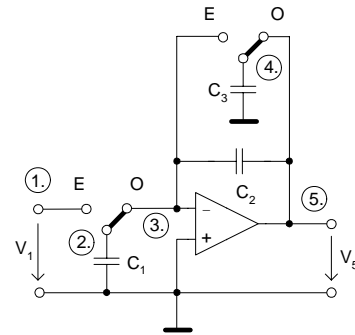

Fig. 1 schematic diagram of the SC circuit from the example

The C_1 capacitor is connected to the second node, the C_2 capacitor then between the third and fifth nodes, which in the simplified starting graph in Fig. 2 is marked by noting C_1 above the second node and C_2 between the third and fifth nodes.

In the even-numbered EE phase nodes 1 and 2 will be connected by closing the switch, which is demonstrated in the graph by their transformation – uniting into a single node $1E.=2E$. The capacity in this resulting node is given generally by the relation $C = a^V \cdot \tilde{C} \cdot a^O \cdot \alpha$, where \tilde{C} is the capacity of the original node, a^V , a^O are then the branches of the transformation graph with the transfers of voltage \rightarrow and of charge \rightarrow . Thus the resulting capacity here will be C_1 .

The operational amplifier is connected to the third node by its inverting input and into the fifth node by its output, and consequently the branch with the charge transfer of the transformation graph goes from the node 3, the branch with the voltage transfer of the transformation graph enters the node 5. Following this transformation graph, the capacity C_2 connected between nodes 3 and 5 then transforms into the resulting capacity of the amount $-C_2$, as the capacitor C_2 is connected to the node 3 by one of its ends, therefore the inherent loop at this node has the transfer C_2 and is transformed according to the equation $C = a^V \cdot \tilde{C} \cdot a^O \cdot \alpha$. The branch between the nodes 3 and 5 with the transfer C_2 is transformed to the inherent loop with the transfer $-C_2$, because in the relation $C = a^V \cdot \tilde{C} \cdot a^O \cdot \alpha$ is now $\alpha = -1$, as the branch of the original graph converts to the inherent loop in the resulting transformed graph. In the odd phase OO by closing the switch the nodes 2 and 3 will be connected and nodes 4 and 5 too, which will demonstrate in the graph by their transformation – uniting into a single node $2O.=3O$. and

$4O.=5O.$, and this resulting node is at the same time the input node of the operational amplifier.

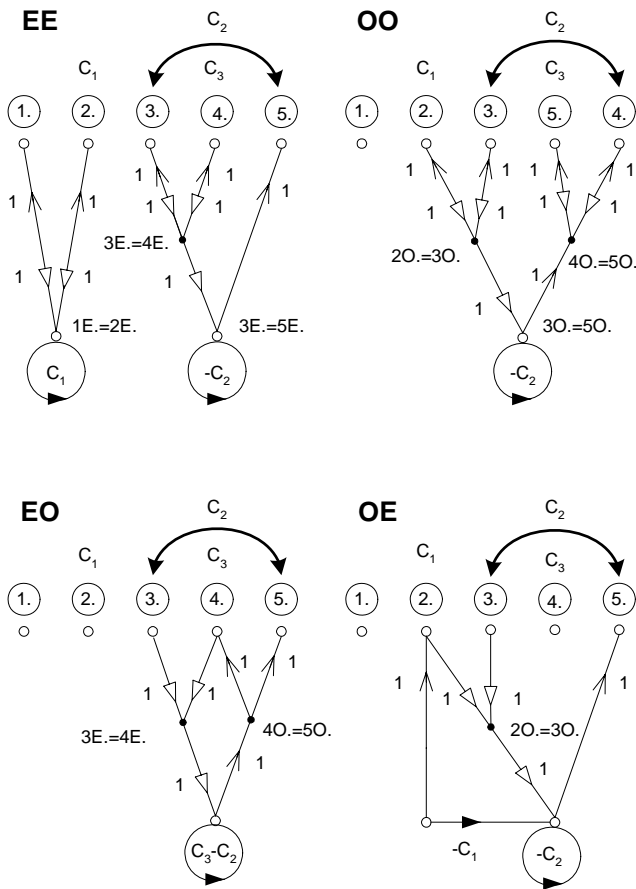

Fig.2 the transformation graphs for EE, OO, EO and OE phases

In the remaining phases EO and OE, we start, according to the equation $C = a^V \cdot \tilde{C} \cdot a^O \cdot \alpha$, along the branch with the voltage transfer a^V from the resulting node to the original node and we enter back to the resulting node along the branch with the charge transfer a^O . The transformation graphs for all the four cases are in Fig.2.

The summary graph obtained from the partial transformed graphs from the Fig.2 by the above mentioned procedure is then shown in Fig.3. First the results of the transformed graphs for EE and OO phases are plotted (in case of this example only) as nodes.

In the next step, the results of the transformed graph for the EO and OE phases multiplied by $-z^{\frac{1}{2}}$ or $z^{\frac{1}{2}}$ are then drawn between these nodes as branches, i.e. the branch with the transfer $-z^{\frac{1}{2}} \cdot (-C_1)$ between the nodes $1E.=2E.$, and $3O.=4O.$, and the branches with the transfers $z^{\frac{1}{2}} \cdot (-C_2)$ between the nodes $3E.=4E.$, and $3O.=4O.$

By evaluating this summary graph, which is done by

substitution into the Mason's formula $T = \frac{\sum P_{(i)} \cdot \Delta_{(i)}}{V - \sum S^{(K)} \cdot V^{(K)}}$,

we get the following final results this way.

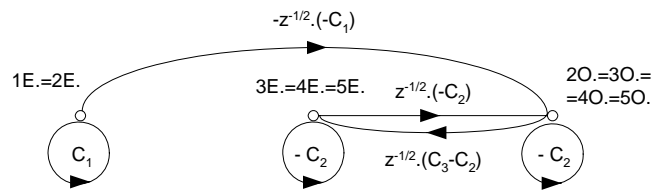

Fig.3 the summary MC-graph of the SC circuit from Fig.1

From the graph it is obvious that the entry node is $1E$ or the first node in the even phase, therefore there will only be transfers from the even phase of the first node. It is further evident from the graph that the exit (i.e. fifth) node exists here both in the even phase as: $5E.(4E.=3E.=5E.)$ and in the odd phase as: $5O.(2O.=3O.=4O.=5O.)$. It is thus possible to express in numbers the two following transfers: $\frac{V_{5O}}{V_{1O}}$ and $\frac{V_{5E}}{V_{1O}}$

for which it holds that:

$$\begin{aligned} \frac{V_{5E}}{V_{1E}} &= \frac{\sum P_{(i)} \cdot \Delta_{(i)}}{V - \sum S^{(K)} \cdot V^{(K)}} = \\ &= \frac{-z^{-\frac{1}{2}} \cdot (-C_1) \cdot z^{\frac{1}{2}} \cdot (C_3 - C_2)}{(-C_2) \cdot (-C_2) - \left[z^{\frac{1}{2}} \cdot (-C_2) \cdot z^{\frac{1}{2}} \cdot (C_3 - C_2) \right]} = \\ &= -\frac{z^{-1} \cdot C_1 \cdot (C_2 - C_3)}{C_2^2 - z^{-1} \cdot C_2 \cdot (C_2 - C_3)} \end{aligned} \quad (1)$$

and for the second one

$$\begin{aligned} \frac{V_{5O}}{V_{1E}} &= \frac{\sum P_{(i)} \cdot \Delta_{(i)}}{V - \sum S^{(K)} \cdot V^{(K)}} = \\ &= \frac{-z^{\frac{1}{2}} \cdot (-C_1) \cdot [-C_2]}{(-C_2) \cdot (-C_2) - \left[z^{\frac{1}{2}} \cdot (-C_2) \cdot z^{\frac{1}{2}} \cdot (C_3 - C_2) \right]} = \\ &= -\frac{z^{\frac{1}{2}} \cdot C_1}{C_2 - z^{-1} \cdot (C_2 - C_3)}. \end{aligned} \quad (2)$$

B. Solving Based on a Two-Graph

A solution of a circuit by the two-graph method of a summary MC-graph constructed on the basis of two-graphs

will be shown in Fig.6. First we draw a partial diagram for the even phase and the odd phases separately by the algorithm described in [5]. These diagrams are in Fig.4, where the node numbers in the squares are the numbers of the nodes of the charge Q-graph and the node numbers in the triangles are the

numbers of the nodes of voltage V-graph after re-numbering the nodes, caused according to the rules stated in [3] by the operational amplifier.

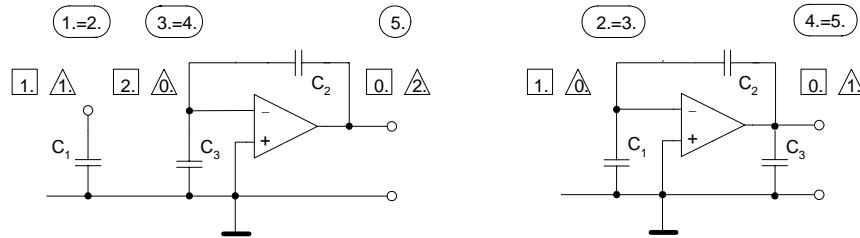

Fig.4 diagrams of circuits for even and odd phases

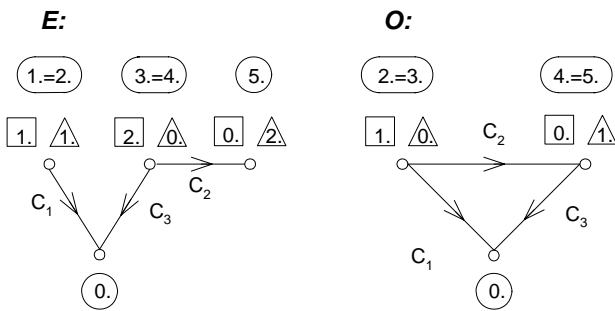

Fig.5 graphs for even and odd phases

To the diagrams for individual phases, we can assign directed graphs drawn in Fig.5. For orientation there are the

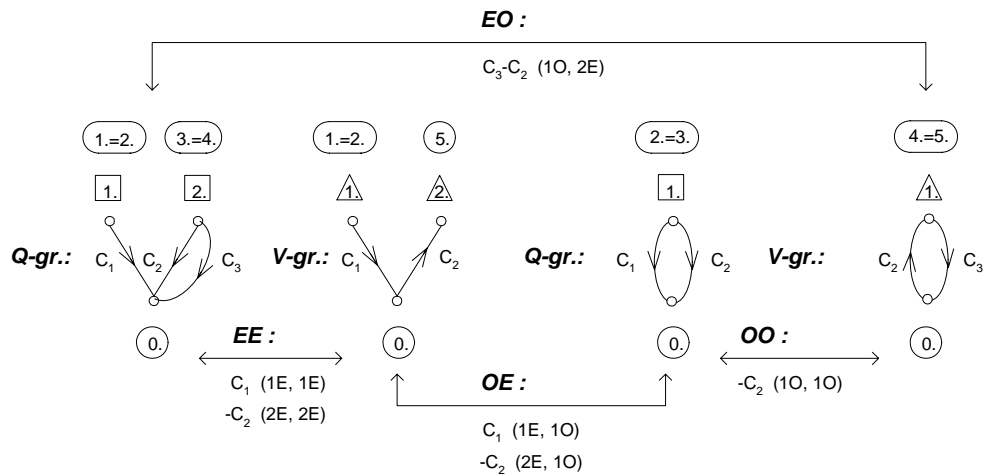

Fig.6 two-graphs for even and odd phases

Summary graph is now constructed by first finding the incomplete common skeletons of the V-graph and the Q-graph in the even phase and in the odd one: in the even phase there is one incomplete common skeleton formed by the C_1 element connected to the node 1 of both graphs, another incomplete

skeleton is formed by the C_2 element connected to the node 2 of both graphs. But as the arrows in the Q-graph and the V-graph aim in the opposite directions, the C_2 element has a negative sign, i.e. there will be $-C_2$. In the odd phase there is an incomplete skeleton formed by C_2 connected to the 1st

node, the arrows in the Q-graph and the V-graph aim in the opposite directions, so C_2 has a negative sign $-C_2$. Thus obtained loops of summary Mason-Coates graph are in Fig.7.

The common skeleton of the V-graph in the E phase and of the Q-graph in the O phase is formed by the C_1 element, whose graph goes from the node 1 in the even phase and from the node 1 in the odd phase, and by the C_2 element, but as the arrows at C_2 in the Q-graph and V-graph go against each other, the C_2 element has got a negative sign, i.e. there is $-C_2$. Thus the graph for the OE phase is given. In the EO phase we look for common incomplete skeletons from the Q-graph in the E phase and from the V-graph for the O phase. There are two branches going parallel with transfers C_2 and C_3 , while the arrows at C_2 go in opposite directions so in the sum of these parallel branches C_2 will have a negative sign: C_3-C_2 .

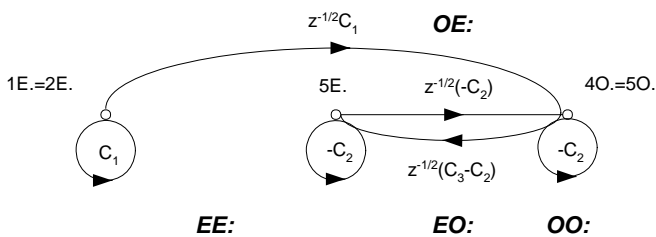

Fig.7 resulting summary MC-graph

The voltage transfers (3) and (4) will now be obtained from a shortened graph, i.e. a graph in which there will not be the entry node's own loop, by means of the Mason's rule [1]:

$$\begin{aligned} \frac{V_{5E}}{V_{1E}} &= \frac{\sum P_{(i)} \cdot \Delta_{(i)}}{V - \sum S^{(K)} \cdot V^{(K)}} = \\ &= \frac{z^{-\frac{1}{2}} \cdot C_1 \cdot z^{-\frac{1}{2}} \cdot (C_3 - C_2)}{(-C_2) \cdot (-C_2) - z^{-\frac{1}{2}} \cdot (C_3 - C_2) \cdot z^{-\frac{1}{2}} \cdot (-C_2)} = \\ &= -\frac{z^{-1} \cdot C_1 \cdot (C_2 - C_3)}{C_2^2 - z^{-1} \cdot C_2 \cdot (C_2 - C_3)} \end{aligned} \quad (3)$$

and for the second one

$$\frac{V_{5O}}{V_{1E}} = \frac{\sum P_{(i)} \cdot \Delta_{(i)}}{V - \sum S^{(K)} \cdot V^{(K)}} =$$

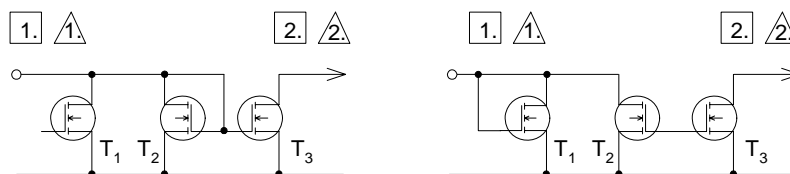

Fig.9. diagrams of circuits for even and odd phases

$$\begin{aligned} &= \frac{z^{-\frac{1}{2}} \cdot C_1 \cdot (-C_2)}{(-C_2) \cdot (-C_2) - z^{-\frac{1}{2}} \cdot (C_3 - C_2) \cdot z^{-\frac{1}{2}} \cdot (-C_2)} = \\ &= -\frac{z^{-\frac{1}{2}} \cdot C_1}{C_2 - z^{-1} \cdot (C_2 - C_3)} \end{aligned} \quad (4)$$

By comparing relations (1), (2) and (3), (4) it is obvious that the results are identical.

III. SOLUTION OF SWITCHED CURRENT CIRCUITS

A circuit with a switched current has got the schematic wiring diagram shown in Fig.1.

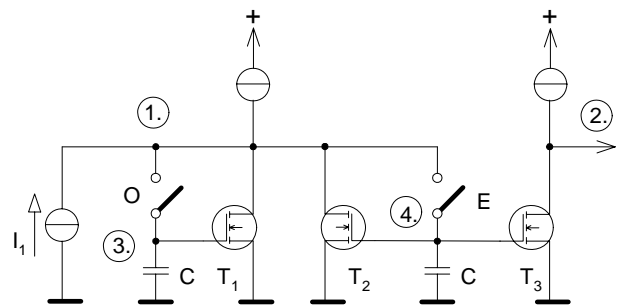

Fig.8 schematic diagram from the example SI circuits

A. Solving Based on Two-Graph

A solution of a switched current circuit [3], [4] by the two-graph method of a summary MC-graph constructed on the basis of two-graphs will be shown in Fig.10. First we draw a partial diagram for the even phase and the odd phases separately by the algorithm described in [3]. These diagrams are in Fig.9, where the node numbers in the squares are the numbers of the nodes of the current I-graph and the node numbers in the triangles are the numbers of the nodes of voltage V-graph.

To the diagrams for individual phases, we can assign directed graphs. For both even and odd phases it is necessary to draw a special voltage and current graphs. These graphs are in Fig.10.

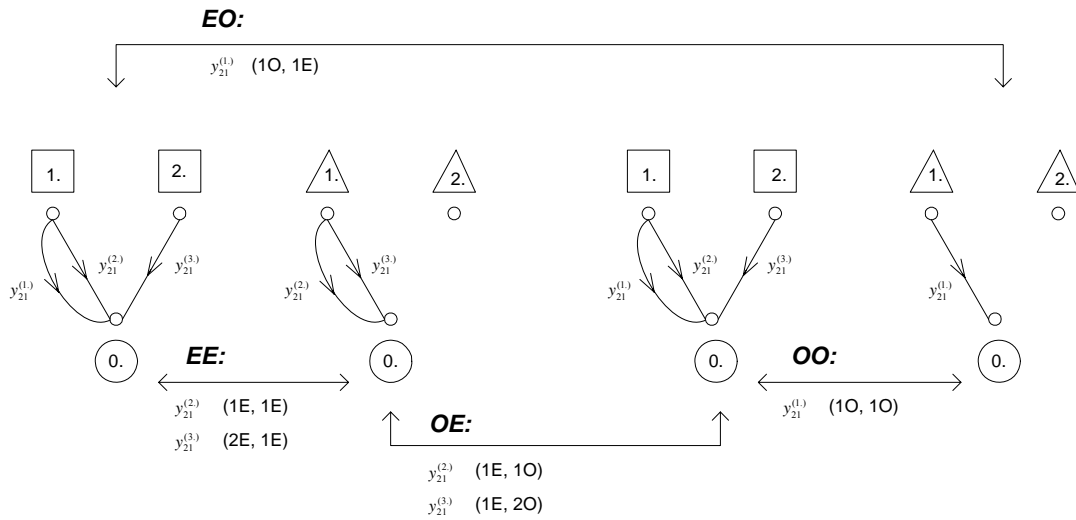

Fig.10. two-graphs for even and odd phases

A summary graph is now constructed by first finding the incomplete common skeletons of the V-graph and the I-graph in the even phase and in the odd one: in the even phase there is one incomplete common skeleton formed by the $y_{21}^{(2)}$ element connected to the node 1 of both graphs, and the element $y_{21}^{(3)}$ connected to the node 2 in I-graph and to the

node 1 in the V-graph. Thus obtained loop with the transfer $y_{21}^{(2)}$ of the summary Mason-Coates graph is in Fig.11 and the branch with the transfer $-y_{21}^{(3)}$, because the sign of all branches is -1. Thus obtained summary Mason-Coates graph is in Fig.11.

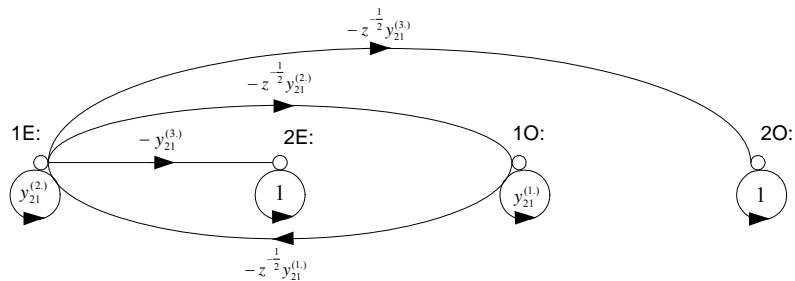

Fig.11 resulting summary MC-graph

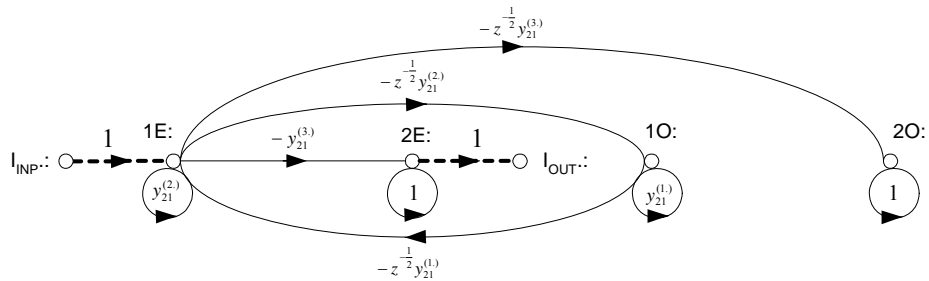

Fig.12 extended summary MC-graph for calculating

The current transfers (5) and (6) will now be obtained from

an extended graph, i.e. a graph must be extended to two branches as it is shown in Fig.12: the first branch from the input node I_{INP} to the node 1E with transfer 1 and the second branch from the node 2E to the node I_{OUT} . The transfer is equal to the transmission of its own loop at the output node. The summary graph is then evaluated by means of the

Mason's rule [1], for example transfer $\frac{I_{2E}}{I_{1E}}$ is (5).

$$\begin{aligned} \frac{I_{OUT}}{I_{INP}} = \frac{I_{2E}}{I_{1E}} &= \frac{\sum P_{(i)} \cdot \Delta_{(i)}}{V - \sum S^{(K)} \cdot V^{(K)}} = \\ &= \frac{-y_{21}^{(3)} \cdot y_{21}^{(1)}}{y_{21}^{(2)} \cdot y_{21}^{(1)} - (-z^{-\frac{1}{2}} \cdot y_{21}^{(2)}) \cdot (-z^{-\frac{1}{2}} \cdot y_{21}^{(1)})} = \\ &= -\frac{y_{21}^{(3)}}{y_{21}^{(2)} \cdot (1 - z^{-1})} \end{aligned} \quad (5)$$

The remaining transfers are following:

$$\begin{aligned} \frac{I_{OUT}}{I_{INP}} = \frac{I_{2O}}{I_{1E}} &= \frac{\sum P_{(i)} \cdot \Delta_{(i)}}{V - \sum S^{(K)} \cdot V^{(K)}} = \\ &= \frac{-z^{-\frac{1}{2}} \cdot y_{21}^{(3)} \cdot y_{21}^{(1)}}{y_{21}^{(2)} \cdot y_{21}^{(1)} - (-z^{-\frac{1}{2}} \cdot y_{21}^{(2)}) \cdot (-z^{-\frac{1}{2}} \cdot y_{21}^{(1)})} = \\ &= -\frac{z^{-\frac{1}{2}} y_{21}^{(3)}}{y_{21}^{(2)} \cdot (1 - z^{-1})} \end{aligned} \quad (6)$$

$$\begin{aligned} \frac{I_{OUT}}{I_{INP}} = \frac{I_{2E}}{I_{1O}} &= \frac{\sum P_{(i)} \cdot \Delta_{(i)}}{V - \sum S^{(K)} \cdot V^{(K)}} = \\ &= \frac{-z^{-\frac{1}{2}} \cdot y_{21}^{(3)} \cdot y_{21}^{(1)}}{y_{21}^{(2)} \cdot y_{21}^{(1)} - (-z^{-\frac{1}{2}} \cdot y_{21}^{(2)}) \cdot (-z^{-\frac{1}{2}} \cdot y_{21}^{(1)})} = \\ &= \frac{z^{-\frac{1}{2}} y_{21}^{(3)}}{y_{21}^{(2)} \cdot (1 - z^{-1})} \end{aligned} \quad (7)$$

$$\frac{I_{OUT}}{I_{INP}} = \frac{I_{2O}}{I_{1O}} = \frac{\sum P_{(i)} \cdot \Delta_{(i)}}{V - \sum S^{(K)} \cdot V^{(K)}} =$$

$$\begin{aligned} &= \frac{-z^{-\frac{1}{2}} \cdot y_{21}^{(3)} \cdot y_{21}^{(1)}}{y_{21}^{(2)} \cdot y_{21}^{(1)} - (-z^{-\frac{1}{2}} \cdot y_{21}^{(2)}) \cdot (-z^{-\frac{1}{2}} \cdot y_{21}^{(1)})} = \\ &= \frac{z^{-1} y_{21}^{(3)}}{y_{21}^{(2)} \cdot (1 - z^{-1})} \end{aligned} \quad (8)$$

IV. CONCLUSION

Let us now briefly compare the two above described graphical methods of solving switched circuits.

All methods were presented in an equally detailed steps to be able to compare.

The method of transformation graphs requires only plotting graphs for all the four switching phases, from which a summary MC graph is plotted and then evaluated by the Mason's rule.

The method of two-graphs further requires drawing schematic diagrams for both the phases and re-numbering nodes in these diagrams. For these two diagrams, it is then necessary to plot directed graphs and to search for common skeletons in them. Only from these the summary MC graph is made up and evaluated by the Mason's rule.

The two-graph method can also be used for circuits with switched currents; again, it is necessary to draw the diagrams for both the phases like in the case of switched capacitor circuits.

While both the graph methods can considerably contribute to switched circuits parameters analysis due to their visual clarity and illustrative nature, the use of transformation graphs seems generally less complicated and easier to use than the two-graph method of switched circuits solution.

REFERENCES

- [1] D. Bielek, *Solving Electronics Circuits*. Praha, BEN Publisher 2004.
- [2] T. Dostál, The Analysis of the Active Components Containing Switched Capacitors by Nodal Voltage Method. *Electronics horizont*, Vol. 45, No.1, 1984, pp. 21-26..
- [3] P. Martinek, P. Boreš, J. Hospodka, *Electrics Filters*. CVUT Publisher Praha, 2003.
- [4] Toumazou, Ch., *Circuits and Systems Tutorials*. IEEE Press Inc., New York, 1996.
- [5] J. Vlach, K. Singhal, *Computer Methods for Circuit Analysis and Design*. Van Nostrand Reynhold New York, 1994.

Zdeňka Dostálová was born in Dačice, CR, 1973. She received the master's degree at Masaryk University in Brno, Czech Republic, in 1996. She has joined the College of Polytechnics Jihlava as a lecturer.

David Matousek was born in Jihlava, 1972. He received the MSc. degree in electronics at the Faculty of Electrical Engineering of CTU in Prague, Czech Republic, in 1996. He joined the Department of the Electronics and Informatics of the College of Polytechnics Jihlava as Assistant Professor.

Bohumil Brtník was born in Jihlava, 1959. He received the MSc. degree in communication engineering and electronics at the BUT of Brno, Czechoslovakia, in 1983. He has joined the Department of the Electronics and Informatics of College of Polytechnics Jihlava as Assistant Professor.