

Tuning of Thermal FEA Using Krylov Parametric MOR for Subsea Application

A. Suleng, T. Jelstad Olsen, J. Šindler, and P. Bárta

Abstract—A dead leg is a typical subsea production system component. CFD is required to model heat transfer within the dead leg. Unfortunately its solution is time demanding and thus not suitable for fast prediction or repeated simulations. Therefore there is a need to create a thermal FEA model, mimicking the heat flows and temperatures seen in CFD cool down simulations.

This paper describes the conventional way of tuning and a new automated way using parametric model order reduction (PMOR) together with an optimization algorithm. The tuned FE analyses replicate the steady state CFD parameters within a maximum error in heat flow of 6 % and 3 % using manual and PMOR method respectively. During cool down, the relative error of the tuned FEA models with respect to temperature is below 5% comparing to the CFD. In addition, the PMOR method obtained the correct FEA setup five times faster than the manually tuned FEA.

Keywords—CFD, convective heat, FEA, model tuning, subsea production

I. INTRODUCTION

ONE of the main activities for flow assurance studies involving subsea production systems are thermal analyses. The aim is to verify or determine the shape and thickness of the insulation layer needed to meet both cool down and high temperature requirements on the subsea equipment. These requirements are set in order to avoid hydrate formation or overheating of temperature sensitive components.

The following driving forces are seen in the area of flow assurance thermal analyses:

- real-time/virtual modeling
- optimization

CFD (Computational Fluid Dynamics) analyses are very time demanding and thus not suitable for real-time modeling. On the other hand, a thermal FEA (Finite Element Analysis) does not account for convective heat transfer within the fluid domains. Including convective heat transfer in the FEA model requires tuning of several parameters to match the heat fluxes

A. Suleng works as a Flow Assurance Senior Engineer at FMC Technologies AS, POB 440, NO-1373 ASKER, Norway (phone: +47 6675 3252; e-mail: ane.suleng@fmcti.com).

T. Jelstad Olsen works as a Flow Assurance Senior Engineer at FMC Technologies AS, POB 440, NO-1373 ASKER, Norway (phone: +47 6679 2907; e-mail: trine.jelstadolsen@fmcti.com).

J.Šindler is working with Advanced FEA & Optimization at Research Center of Manufacturing Technology, Faculty of Mechanical Engineering, Czech Technical University, Horska 3, 128 00 Prague 2, Czech Republic (phone: +420 221 990 912; e-mail: J.Sindler@rcmt.cvut.cz).

P. Bárta works as a Flow Assurance Specialist Engineer at FMC Technologies AS, POB 440, NO-1373 ASKER, Norway (phone: +47 6675 3243; e-mail: pavel.barta@fmcti.com).

and temperatures seen in a model with fully resolved convective heat transfer, i.e. the CFD model. Such a tuned FEA model can be further reduced and used for real-time modeling of a subsea system.

Due to strict requirements on the insulation material and to large insulation volumes, the cost of insulation material represents a significant part of the subsea equipment price. In combination with the standard design process, there is a great potential for optimizing the insulation volume and thereby reducing the cost.

A solution to these needs is to create fast responding and accurate models by the means of the Model Order Reduction (MOR) methodology and include these into optimization algorithms to identify the optimal set of input parameters for a given goal.

Considerable effort has been put into research to comply with similar needs in various industries. One of the most promising methods is Parametric Model Order Reduction (PMOR). There has been a lot of research involving PMOR recently showing progress and soundness of the method [1], [2], [3], [4], [5], [6], [7]. This paper deals with PMOR in order to assess its usability for a given field. The requirement posed on PMOR is computational efficiency. The PMOR should outperform the conventional approach.

PMOR will be used in conjunction with optimization techniques. There are several options to choose from. The classification of the problem is nonlinear programming (NLP) [8]. There are two approaches possible:

- multi objective optimization [9], [10]
- single objective optimization with constraints [11]

The single objective optimization approach was chosen for the presented case.

A. Tuning FEA to CFD Results

The flow pattern in the subsea equipment during a cool down scenario is induced by buoyancy. The intensity of the convective heat transfer and the subsequent fluid motion is thus given by the temperature difference within the fluid domain. This gradient is typically between the wall temperature at a cold and a warm spot. Since the cool down of subsea equipment is a relatively slow process, the CFD model can be very well approximated by a FE cool down model.

The following steps are required to create a tuned FEA cool down model of subsea equipment with dominant convective heat transfer:

- 1) CFD simulation of the initial thermal state preceding cool down of the equipment

- 2) A selection of essential parameters, such as heat fluxes between fluid and wetted wall and temperatures in the fluid domain, are extracted from the CFD simulation
- 3) FE analysis of the initial thermal state of the equipment
- 4) FEA parameters, fluid conductivities and HTC (Heat Transfer Coefficient) values between the production fluid and the adjoining wall, are identified in an iterative process where the FEA results aim to match the CFD results
- 5) FE analysis with the identified parameters used both during the initial state and cool down period approximates the CFD cool down simulation

II. MODEL DESCRIPTION

The Tuned FEA approach simplifies modeling of convective heat transfer during steady state and cool down. Thus the thermal behavior of the validation model must be strongly driven by convective heat transfer.

A manifold dead leg represents a typical area where convective heat transfer plays an important role both during production and cool down. A dead leg is a part of a production system, i.e. pipe (Fig. 1), containing a stagnant fluid volume (Fig. 2). The manifold model chosen to validate the modeling approach consists of a header, a dead leg and a valve. Flowing production fluid heats up the header so it becomes the warmest part of the system. The accumulated heat in the header is the driving force for the convective heat transfer in the dead leg during the cool down. Heat is transported from the header towards the cold spot by convection, both during production and cool down. The conductive heat transfer is by comparison negligible. The valve acts as a cold spot draining heat from the system.



Fig. 1 Pipe/Valve domain

Since the model is symmetric only half of it is considered. The model consists of a valve and a production fluid domain in a steel pipe covered by insulation, see Fig. 3.

All external surfaces are exposed to an ambient sea temperature of 5 °C and a heat transfer coefficient of 1000 W/m²K is applied. The initial header temperature is set to 50 °C.

Adiabatic boundaries are assumed on the remaining outer faces of the model, at the header ends and at the symmetry plane of the valve.

The model has been built in ANSYS. The CFD simulation and the FE analysis were performed using respectively ANSYS CFX and ANSYS Mechanical.

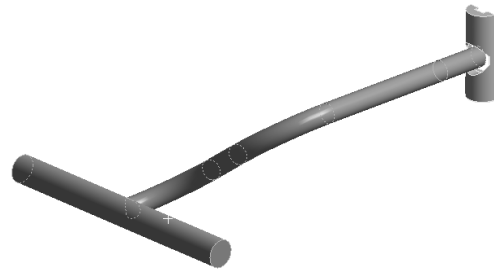

Fig. 2 Production fluid domain and valve cavity

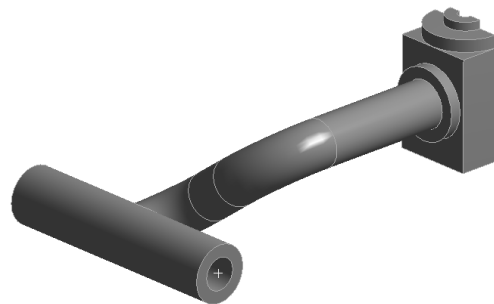

Fig. 3 Insulation domain

A. CFD Modeling

The SST turbulence model has been used to approximate the effect of turbulence in the fluid domain.

The computational mesh mainly consists of tetrahedral elements; see Fig. 4 for the fluid mesh. Prism elements have been used to resolve the production fluid boundary layers to $y^+ = 1$. The total number nodes is 59 428 for solid domains and 261 249 for fluid domain (production fluid).

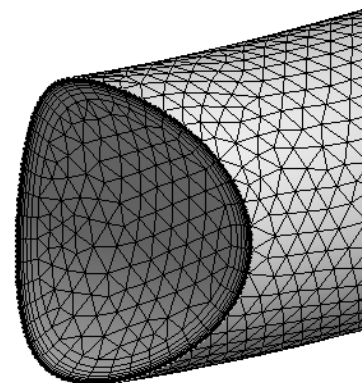

Fig. 4 Computational mesh – CFD

B. FEA Model

The FEA approach does not account for convective heat transfer. Hence the production fluid is modeled as a solid, i.e. considering conductive heat transfer only. The dead leg is split into five domains, see Fig. 5. The thermal conductivity and HTC in these domains are used to tune the FEA results to match the CFD results.

A fine mesh is used to display the numerical efficiency of the method and generalize the findings on larger models. The mesh consists of 5 322 721 elements and 956 488 nodes, see Fig. 6.

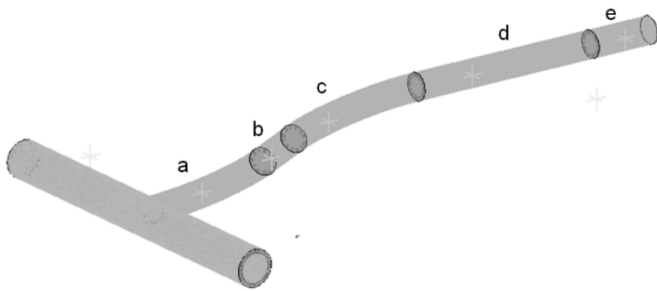

Fig. 5 FEA production fluid domain – header (green), dead leg (a - e)



Fig. 6 FEA computational mesh - header

III. APPROACH TO MANUALLY TUNED FEA

The following steps are required to create a manually tuned FEA cool down model of a subsea equipment with dominant convective heat transfer:

- 1) CFD simulation of the initial thermal state preceding cool down of the model
- 2) Essential parameters are extracted from the CFD simulation:
 - a) heat fluxes between production fluid and wetted wall for the header domain (Q_h) and the dead leg domains a-e (Q_a, Q_b, Q_c, Q_d, Q_e)
 - b) overall heat losses through insulation and valve (Q_{insu}, Q_{valve})
 - c) minimum temperature in the dead leg domain (T_e)
- 3) FEA analysis of the initial thermal state of the model
- 4) The initial state FEA model is rerun with intuitive choices of the tuned parameters until the essential parameters in 2) are observed in the initial state. The tuned parameters are:

- a) 5 fluid conductivity values, one for each of the dead leg domains a-e (k_a, k_b, k_c, k_d, k_e)
- b) 6 HTC values, between production fluid domains and surrounding wall ($h_h, h_a, h_b, h_c, h_d, h_e$)
- 5) The FEA model with the identified parameters used both during initial state and cool down period approximates the CFD cool down simulation

IV. PARAMETRIC MOR

The model order reduction (MOR) based on Krylov subspaces was chosen to produce parametric reduced models [12]. Krylov MOR is based on a projection onto a subspace

$$T = V_n q + \epsilon \quad (1)$$

where V_n is generated using Krylov MOR, q are generalized coordinates and ϵ is the residue. The system equations in question have the forms

$$C\dot{T}(t) + KT(t) = Qu(t) \quad (2)$$

where C and K are the specific heat matrix and the conductivity matrix. T is temperature field and Q are imposed boundary conditions. Substituting (1) into (2) and imposing Galerkin conditions leads to

$$C_n \dot{q} + K_n q = Q_n \quad (3)$$

$$K_n = V_n^T K V_n$$

$$C_n = V_n^T C V_n \quad (4)$$

$$Q_n = V_n^T Q$$

The system (3) is the reduced order representation of the system (2). From (4) it follows that if K, C or Q are linear combinations of their submatrices the reduction will still be valid.

Consider K as a linear combination of its submatrices

$$K = \sum_i p_i K_i \quad (5)$$

then substituting (5) into (4) gives

$$K_n = V_n^T \sum_i p_i K_i V_n = \sum_i p_i V_i^T K_i V_n. \quad (6)$$

Hence it is easily possible to generate parametric reduced systems in the case where the matrices C and K are linear combination of their sub matrices. The projection matrix is used only once for the base system.

The sub matrices of the conductivity matrix are linearly depending on the conductivities of the materials or contacts. The sub matrices of the specific heat matrix are linearly depending on the specific heat and the densities of the materials. Therefore the system (4) is easily parameterized

with these quantities. The parameterized reduced system is ready to be used in the optimization algorithm.

V. OPTIMIZATION ALGORITHMS

The goal is to obtain the parameters in Table II by tuning the conductivities and heat transfer coefficients (Table I). The optimization problem is defined as

$$\min \sum_{i=1}^8 |Q_i - Q_i^{CFD}| \quad (7)$$

$$T_e \in < 32, 33.6 >$$

where Q_i and Q_i^{CFD} are the total heat going into the dead leg obtained from respectively the FE analysis and the CFD analysis. Such a problem is classified as nonlinear programming [8]. The L-BFGS-B algorithm [11] was chosen to solve (7).

The starting point of the optimization algorithm was generated using design of experiment with maximum entropy sampling using 1000 samples [13], [14]. This ensures that a good starting point is chosen and enhances convergence of the L-BFGS-B algorithm.

VI. RESULTS

The header fluid temperatures, as well as the minimum temperatures in the upper bend and in the end of the dead leg, were chosen for comparison between the full CFD and Tuned FEA cool down simulations (Fig. 7). The temperatures are denoted as:

- header temperature - T_h
- minimum temperature at upper bend - T_c
- minimum temperature at end of dead leg - T_e

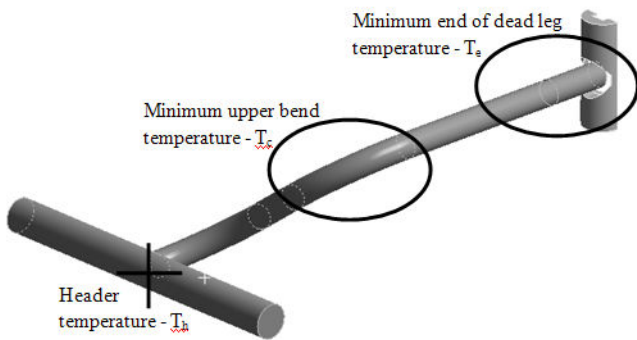

Fig. 7 Temperature monitor points

A. CFD Simulation of the Initial State

A steady state CFD simulation has been performed to obtain the temperature and heat flux pattern in the equipment induced by the warm production fluid in the header. This solution was used to initialize the CFD, manually tuned and PMOR tuned cool down simulations.

The adaptive time step option, based on a mean Courant number equal to 20, was used to determine the time step

during the transient part of the simulation. The approximate size of the time step during the transient simulation was 0.6 s.

The temperature distribution in the dead leg is shown in Fig. 8. An overview of the extracted parameters to which the FEA model is tuned is given in Table II.

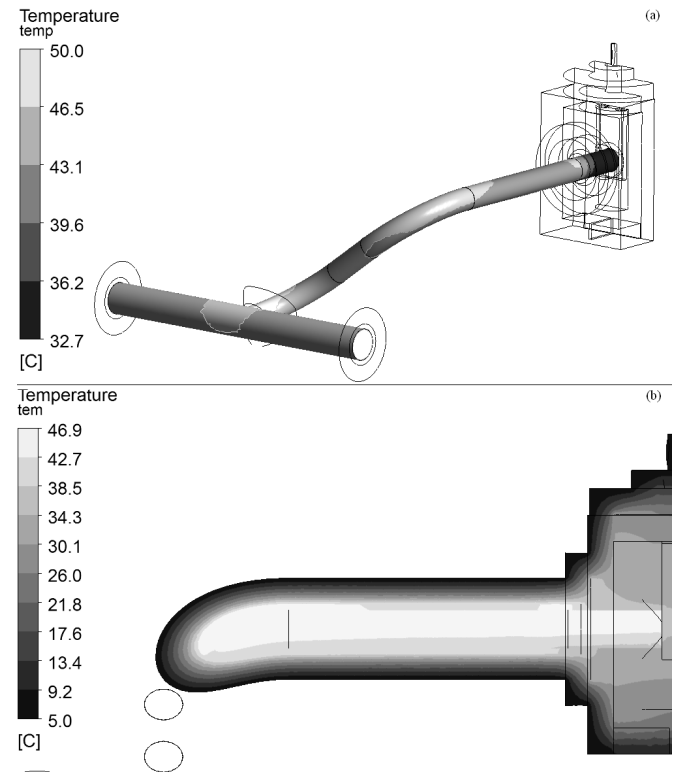

Fig. 8 CFD model: Beginning of cool down ($t = 0$ s) – dead leg temperatures

B. CFD Cool Down Simulation

All production fluid residuals (RMS) have been kept between $1E-04$ and $1E-03$ and domain imbalances within 1% during the entire cool down simulation. The total length of the simulation was set to 54000 s (15 hours).

As for the initial state, the adaptive time step option, based on a mean Courant number equal to 20, was used to determine the time step during the transient part of the simulation. The approximate size of the time step during the transient simulation varied from 0.6 s to 1.5 s.

The temperatures during cool down simulation are displayed in Fig. 9 for the selected locations T_h , T_c and T_e (for reference see Fig. 7). The temperature distribution in the production fluid domain is shown on Fig. 10.

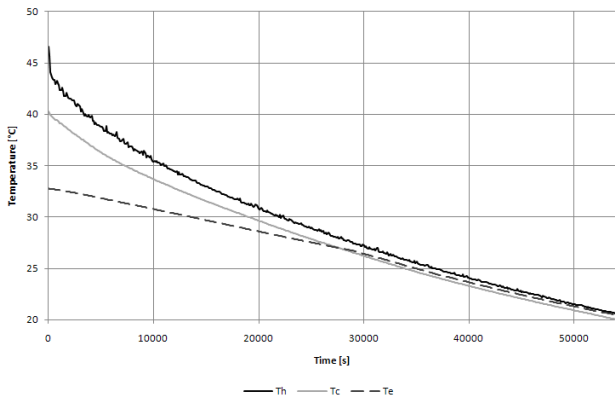

Fig. 9 Temperatures during CFD cool down simulation

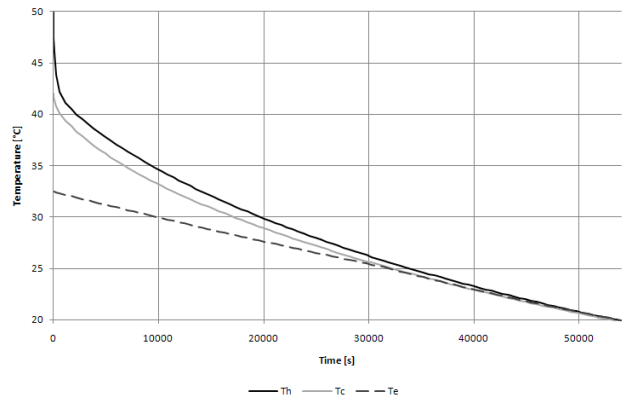

Fig. 11 Temperatures during manually tuned FEA cool down simulation

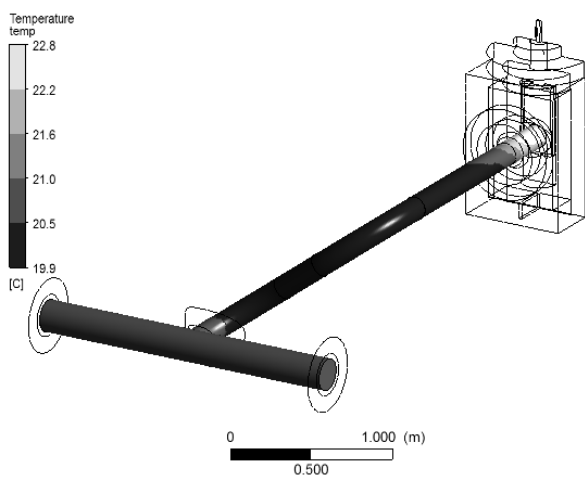

Fig. 10 CFD cool down simulation (t = 54000 s) - production fluid temperature

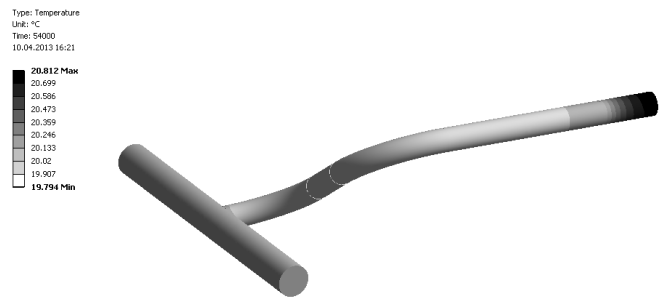

Fig. 12 Manually tuned FEA cool down simulation (t = 54000 s) - production fluid temperature

C. Manually Tuned FEA Cool Down Simulation

The steady state FEA simulation approximates the CFD initial state simulation by using the tuned parameters presented in Table I. The discrepancy between the manually tuned FEA and the CFD in the selected essential parameters, see Table II, are shown in Table III.

The subsequent cool down simulation, based on the identified parameters, is run with maximum time step of 540 s for 15 hours. The cool down curves for the selected locations and the production fluid temperatures after the end of cool down is displayed in Fig. 11 and Fig. 12.

D. PMOR Cool Down Simulation

The parameters approximating the CFD model were found by means of PMOR and are presented in Table I. The discrepancy between the PMOR FEA and the CFD simulation in the selected essential parameters are shown in Table II and Table III.

The subsequent cool down simulation, based on the identified parameters, is run with maximum time step of 5400 s for 15 hours. The cool down curves for selected locations after the end of cool down is displayed in Fig. 13.

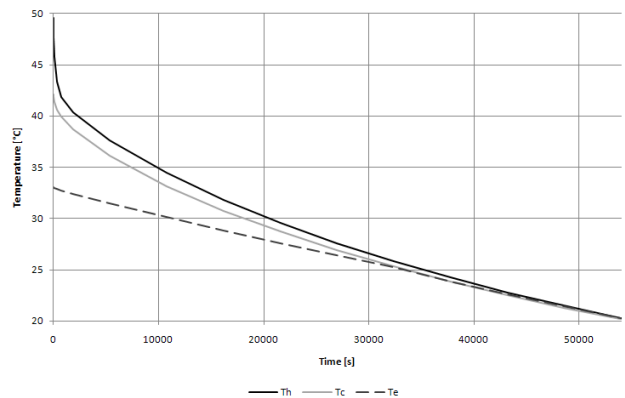

Fig. 13 Temperatures during PMOR FEA cool down simulation

TABLE I
 OVERVIEW OF THE TUNED PARAMETERS

	Conductivity [W/mK]					Heat transfer coefficient [W/m ² K]					
	k _a	k _b	k _c	k _d	k _e	h _h	h _a	h _b	h _c	h _d	h _e
Manually Tuned FEA	2500	2500	2000	2500	120	15	15	35	90	120	250
PMOR FEA	2437	2561	2076	2419	131	14.9	16.5	37.8	89.1	111.6	266.4

TABLE II
 OVERVIEW OF THE SELECTED ESSENTIAL PARAMETERS

	Heat flow [W]							Temp. [°C]	
	Q _h	Q _a	Q _b	Q _c	Q _d	Q _e	Q _{insu}	Q _{valve}	T _e
CFD	133	31	19	45	60	76.2	332.8	36.9	32.8
Manually Tuned FEA	132.7	30.9	19.2	43.5	58.2	74.0	334	34.7	32.7
PMOR FEA	131.8	32.2	19.2	43.8	58.7	75.7	332.4	35.4	33

VII. COMPARISON

A. Steady State

The identified sets of FEA parameters, found to approximate the CFD simulation, are compared in Table I. The parameters found manually and by means of PMOR show the same trend and are similar in values. The parameters listed in Table II show a good agreement between the FEA approximations and the CFD results during steady state. Thus it can be concluded that both of the methods approach the CFD results.

B. Cool Down

The temperatures resulting from the FEA (T_{FEA}) are compared to the CFD (T_{CFD}) temperature results by the absolute error $\delta(T(t))$:

$$\delta(T(t)) = T_{CFD}(t) - T_{FEA}(t) \quad (1)$$

The absolute error does not capture the relativity of the temperature error towards the decreasing temperature potential. Thus the absolute error naturally minimizes towards the end of the cool down. A relative error, κ [%], based on ambient temperature $T_{ambient}$ is therefore introduced and is used to evaluate the match between the temperatures resulting from FEA approximations (T_{FEA}) and CFD simulation (T_{CFD}).

$$\kappa(T_{FEA}(t)) = \frac{T_{CFD}(t) - T_{FEA}(t)}{T_{CFD}(t) - T_{ambient}} \cdot 100\% \quad (2)$$

The absolute and relative temperature differences are shown in Fig. 14 and Fig. 15.

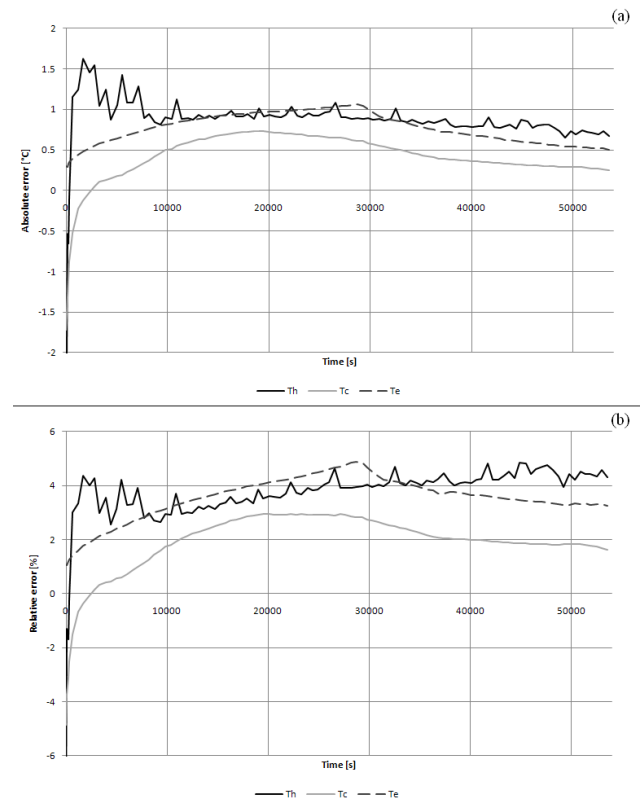

Fig. 14 Absolute (a) and relative (b) temperature difference between CFD and manually tuned FEA cool down simulations

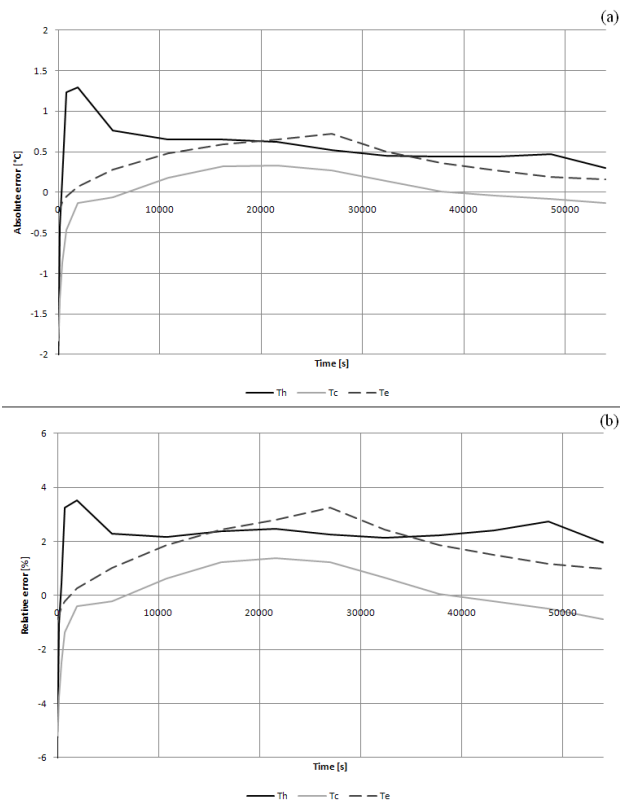

Fig. 15 Absolute (a) and relative (b) temperature difference between CFD and PMOR tuned FEA cool down simulations

VIII. CONCLUSIONS

Overall nine heat flow and temperature parameters have been extracted from the CFD dead leg simulation. These parameters have been replicated in the FEA models by tuning eleven internal FEA parameters. The relative difference between the CFD and FEA steady state heat flows is below 6 % and 3 % in the case of manual and PMOR method respectively (Table III). The absolute temperature difference is below 0.2 °C (Table II), for both of the tuning methods.

The tuned FEA models have been used for cool down simulations and compared to the CFD simulation. The absolute and relative errors in temperature stay below 1 °C and 5 %, respectively, in the selected location throughout most of the cool down simulation. This is an acceptable level of approximation for subsea real-time applications.

The PMOR method shortens the steady state solution time by a factor of 144000 (Table IV) comparing to the FEA model. This in combination with the optimization algorithm represents a very fast and robust solution to multivariable FEA optimizations, which superiorly outperforms the conventional approach.

TABLE III
 RELATIVE DIFFERENCE BETWEEN THE FEA AND CFD MODELS DURING STEADY STATE

	Heat flow [%]								Temp. [°C]
	Q _h	Q _a	Q _b	Q _c	Q _d	Q _e	Q _{insu}	Q _{valve}	T _e
Manually Tuned FEA	-0.2	-0.3	1.1	-3.3	-3.0	-2.9	0.4	-6.0	-0.1
PMOR FEA	-0.9	3.9	1.1	-2.7	-2.2	-0.7	-0.1	-0.9	0.2

TABLE IV
 TIME DURATION

	Setup [h]	Steady state solution [h]	Number of iteration loops [-]	Tuning [h]	Total [h]
Manually Tuned FEA	0	0.12	40	4.8	4.8
PMOR FEA	<0.7	~3 ms	2000	6 s	<1

REFERENCES

- [1] U. Baur, C. Beattie, P. Benner and S. Gugercin, "Interpolatory Projection Methods for Parameterized Model Reduction," *SIAM J. Sci. Comput.*, vol. 33, no. 5, pp. 2489-2518, oct 2011.
- [2] T. Bechtold, D. Hohlfeld, E. B. Rudnyi and M. Gunther, "Efficient extraction of thin-film thermal parameters from numerical models via parametric model order reduction," *Journal of Micromechanics and Microengineering*, vol. 20, no. 4, p. 045030, 2010.
- [3] L. Daniel, C. S. Ong, S. C. Low, K. H. Lee and J. K. White, "A multiparameter moment-matching model-reduction approach for generating geometrically parameterized interconnect performance models," *IEEE Trans. on CAD of Integrated Circuits and Systems*, pp. 678-693, 2004.
- [4] O. Farle, V. Hill, P. Ingelstram and R. Dyczij-Edlinger, "Multi-parameter polynomial order reduction of linear finite element models," *Mathematical and Computer Modelling of Dynamical Systems*, vol. 14, no. 5, pp. 421-434, 2008..
- [5] A. T.-M. Leung and R. Khazaka, "Parametric model order reduction technique for design optimization," in *2005 International Symposium on Circuits and Systems*, 2005.
- [6] P. Li, F. Liu, X. Li, L. T. Pileggi and S. R. Nassif, "Modeling Interconnect Variability Using Efficient Parametric Model Order Reduction," in *Proceedings of the conference on Design, Automation and Test in Europe - Volume 2*, Washington, DC, USA, 2005.
- [7] E. B. Rudnyi, L. H. Feng, M. Salleras, S. Marco and J. G. Korvink, "Error Indicator to Automatically Generate Dynamic Compact Parametric Thermal Models," in *THERMINIC 2005*, 11th

International Workshop on Thermal Investigations of ICs and Systems, 27 - 30 September 2005, Belgirate, Lake Maggiore, Italy.

- [8] M. Avriel, *Nonlinear Programming: Analysis and Methods*, Dover Publications, 2003.
- [9] K. Miettinen, *Nonlinear Multiobjective Optimization*, Kluwer Academic Pub, 1999.
- [10] K. Deb, A. Pratap, S. Agarwal and T. Meyarivan, "A fast and elitist multiobjective genetic algorithm: NSGA-II," *Evolutionary Computation*, IEEE Transactions on, vol. 6, no. 2, pp. 182-197, apr 2002.
- [11] J. L. Morales and J. Nocedal, "Remark on algorithm 778: L-BFGS-B: Fortran subroutines for large-scale bound constrained optimization," *ACM Trans. Math. Softw.*, vol. 38, no. 1, pp. 71-74, dec 2011.
- [12] A. C. Antoulas, *Approximation of Large-Scale Dynamical Systems* (Advances in Design and Control), Philadelphia, PA, USA: Society for Industrial and Applied Mathematics, 2005.
- [13] P. Sebastiani and H. P. Wynn, "Maximum entropy sampling and optimal Bayesian experimental design," *Journal of the Royal Statistical Society: Series B (Statistical Methodology)*, vol. 62, no. 1, pp. 145-157, 200.
- [14] C.-W. Ko, J. Lee and M. Queyranne, "An Exact Algorithm for Maximum Entropy Sampling," *Operations Research*, vol. 43, no. 4, pp. 684-691, July/August 1995.