

Sensitivity of Small Disturbance Angle Stability to the System Parameters of Future Power Networks

Nima Farkhondeh Jahromi, George Papaefthymiou, and Lou van der Sluis

Abstract—The incorporation of renewable energy sources for the sustainable electricity production is undertaking a more prominent role in electric power systems. Thus, it will be an indispensable incident that the characteristics of future power networks, their prospective stability for instance, get influenced by the imposed features of sustainable energy sources. One of the distinctive attributes of the sustainable energy sources is exhibiting the stochastic behavior. This paper investigates the impacts of this stochastic behavior on the small disturbance rotor angle stability in the upcoming electric power networks. Considering the various types of renewable energy sources and the vast variety of system configurations, the sensitivity analysis can be an efficient breakthrough towards generalizing the effects of new energy sources on the concept of stability. In this paper, the definition of small disturbance angle stability for future power systems and the iterative-stochastic way of its analysis are presented. Also, the effects of system parameters on this type of stability are described by performing a sensitivity analysis for an electric power test system.

Keywords—Power systems stability, Renewable energy sources, Stochastic behavior, Small disturbance rotor angle stability.

I. INTRODUCTION

THE fast growing application of sustainable energy sources and the liberalization of the electricity market, impose major structural changes to the current power systems. Also, in near future, electric power systems will operate closer to their marginal limits which itself is an unavoidable consequence of increasing the number of interconnections. Considering these reasons, together with the major switching actions due to the connection of renewable energy sources, the stability of future power networks undertakes a more highlighted role from an industrial perspective.

Modern power systems are both large scale and complex. Because of deregulation, the configuration of interconnected networks is always in a state of change. Therefore, a method of stability analysis, which considers the vast variety of states, is of interest. Such a method should be able to combine the imposed stochastic behavior of the applied renewable energy sources and the deterministic approach of stability analysis.

A possible methodology to analyze the small disturbance stability in the prospective power systems is to make use of an iterative-stochastic approach. By this approach, the uncertain

Nima Farkhondeh Jahromi is with the Faculty of Electrical Engineering, Mathematics and Computer Science, Delft University of Technology, The Netherlands (e-mail: N.FarkhondehJahromi@tudelft.nl).

George Papaefthymiou is with both Ecofys, Berlin, Germany and the Faculty of Electrical Engineering, Mathematics and Computer Science, Delft University of Technology, The Netherlands (e-mail: G.Papaefthymiou@tudelft.nl).

Lou van der Sluis is with the Faculty of Electrical Engineering, Mathematics and Computer Science, Delft University of Technology, The Netherlands (e-mail: L.vanderSluis@tudelft.nl).

nature of sustainable energy sources is stochastically modeled and subsequently, for each sample of this model an iterative linear analysis is performed. This approach analyzes all possible combinations of loads and the sustainable electricity generations. Eventually, this method is expected to reveal the most vulnerable operating points of the system. Applying such a method enables us to measure the sensitivity of small disturbance stability with respect to the system parameters. This publication develops a sensitivity analysis of the small disturbance angle stability in an electric power test system which is modified by the connection of several local renewable power producers.

This paper is organized as follows: Section II describes the conventional analysis method of small disturbance angle stability. In section III, the iterative-stochastic method to analyze the small signal stability is discussed. A numerical example and conclusions are presented in section IV and section V, respectively.

II. CONVENTIONAL ANALYSIS METHOD OF SMALL DISTURBANCE ANGLE STABILITY

Small disturbance angle stability is the ability of an electric power system to maintain synchronism when it is subjected to small disturbances [1]. This section summarizes the conventional analysis method of small disturbance angle stability in electric power systems. Full details can be found in [2], [3] and the references therein. This section also provides the points at which some modifications are required for analyzing the small signal stability in the power networks equipped with the locally distributed renewable energy sources.

A. Forming the System Dynamics by Nonlinear Differential Equations

Fig. 1 shows a power system with $n + N$ nodes. The first n are internal machine nodes and the remaining N are load buses. $\bar{E}_k = E'_k \angle \delta_k$ ($k = 1 \dots n$) is the internal machine voltage phasor behind the transient reactance x'_{dk} including the transformer reactance, if present. E'_k is the magnitude of the internal machine voltage and δ_k is the internal machine angle of the k -th machine. $\bar{V}_k = V_k \angle \theta_k$ ($k = n+1, \dots, n+N$) is the load bus voltage phasor with magnitude V_k and phase angle θ_k .

When we assume that loads are represented by constant impedances, the mechanical power input to generators is constant and saliency of the rotors is neglected ($x'_d = x'_q$), then the required equations to describe the system dynamics can be formed in the following way:

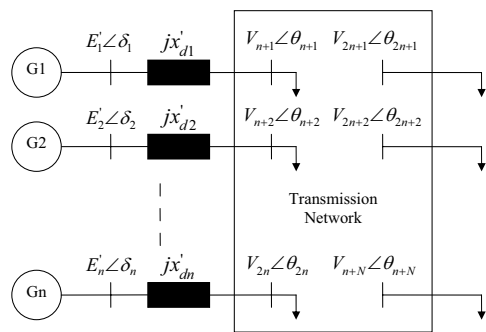

Fig. 1. A multi-machine power system

After a power flow calculation, the equivalent steady state impedance load at each node is calculated and added to the admittance matrix:

$$\bar{y}_{Load,k} = \frac{P_{Load,k} - jQ_{Load,k}}{V_k^2}, \quad k = n + 1 \dots n + N \quad (1)$$

The connection of a renewable energy source at the k -th node, introduces the load admittance $\bar{y}_{Load,k}$ as a function of the behavior of the aforesaid energy source. This function may result in negative values when the generation exceeds the consumption.

The internal machine voltages can be calculated during the steady state operation:

$$\bar{E}'_k = \bar{V}_{n+k} + jx'_{dk} \frac{P_{Gk} - jQ_{Gk}}{\bar{V}_{n+k}^*}, \quad k = 1 \dots N \quad (2)$$

Due to the input of the sustainable energy sources, the generated active and reactive powers can change based on the imposed behavior of such sources of energy.

The \bar{Y}_{bus} matrix can be completed by adding the admittances corresponding to the generator transient reactance. This augmented matrix can be written as

$$\bar{Y}_{bus} = \begin{pmatrix} \bar{Y}_A & \bar{Y}_B \\ \bar{Y}_C & \bar{Y}_D \end{pmatrix} \quad (3)$$

The definition of \bar{Y}_{bus} matrix and Kirchhoff's Current Law (KCL) at each node [4] give:

$$\begin{pmatrix} \bar{I}_G \\ \bar{0} \end{pmatrix} = \begin{pmatrix} \bar{Y}_A & \bar{Y}_B \\ \bar{Y}_C & \bar{Y}_D \end{pmatrix} \begin{pmatrix} \bar{E}_G \\ \bar{V}_L \end{pmatrix} \quad (4)$$

\bar{E}_G represents the internal machine voltages and \bar{V}_L represents load bus voltages.

Relation (4) gives:

$$\bar{I}_G = \bar{Y}_A \bar{E}_G + \bar{Y}_B \bar{V}_L \quad (5)$$

$$\bar{0} = \bar{Y}_C \bar{E}_G + \bar{Y}_D \bar{V}_L \quad (6)$$

From equation (6):

$$\bar{V}_L = -\bar{Y}_D^{-1} \bar{Y}_C \bar{E}_G \quad (7)$$

Replacing (7) in (5) gives:

$$\bar{I}_G = (\bar{Y}_A - \bar{Y}_B \bar{Y}_D^{-1} \bar{Y}_C) \bar{E}_G = \bar{Y}_{RNM} \bar{E}_G \quad (8)$$

The active power injected into the internal machine node k is calculated by

$$\begin{aligned} P_{Gk} &= \text{Re}\{\bar{E}'_k \bar{I}_{Gk}^*\} \\ &= E_k'^2 G_{kk} + \sum_{l=1, l \neq k}^n E_k' E_l' (B_{kl} \sin(\delta_{kl}) + G_{kl} \cos(\delta_{kl})) \end{aligned} \quad (9)$$

Where $\delta_{kl} = \delta_k - \delta_l$. G_{kk} is the short circuit conductance of the k -th machine. G_{kl} is the conductance in \bar{Y}_{RNM} , $k \neq l$. B_{kl} is the susceptance in \bar{Y}_{RNM} , $k \neq l$.

The mechanical motion of the k -th machine ($k = 1 \dots n$) is given by

$$\dot{\delta}_k = \omega_k \quad (10)$$

$$\begin{aligned} \dot{\omega}_k &= \frac{1}{M_k} [P_{mk} - D_k \omega_k - E_k'^2 G_{kk} \\ &\quad - \sum_{l=1, l \neq k}^n E_k' E_l' (B_{kl} \sin(\delta_{kl}) + G_{kl} \cos(\delta_{kl}))] \end{aligned} \quad (11)$$

Where ω_k is the rotor speed deviation of the k -th machine with respect to the synchronous speed.

B. Linearization Around the Equilibrium Points

To find the equilibrium point of the power system depicted in Fig. 1, performing a power flow calculation is the solution. Consequently, the equilibrium vector of rotor angles Δ^{EP} is found by applying equation (2). making use of the definition of equilibrium point for a dynamic system [5], [6] and applying equation (10), the equilibrium vector of rotor speed $\Omega^{\text{EP}} = \bar{0}$, is found.

Linearization of the system, equations (10) and (11), around its equilibrium point, based on the first term of the Taylor's expansion [7], gives:

$$\begin{aligned} \begin{pmatrix} \Delta \dot{\Delta}_{n \times 1} \\ \Delta \dot{\Omega}_{n \times 1} \end{pmatrix} &= \begin{pmatrix} \bar{0} & \bar{I} \\ -\mathbf{M}^{-1} \mathbf{K} & -\mathbf{M}^{-1} \mathbf{D} \end{pmatrix} \begin{pmatrix} \Delta \Delta_{n \times 1} \\ \Delta \Omega_{n \times 1} \end{pmatrix} \\ &= \mathbf{A}_{state} \begin{pmatrix} \Delta \Delta_{n \times 1} \\ \Delta \Omega_{n \times 1} \end{pmatrix} \end{aligned} \quad (12)$$

Where $\bar{0}$ is the $n \times n$ zero matrix. \bar{I} is the $n \times n$ identity matrix. \mathbf{M} is an $n \times n$ matrix with entries $M_{ii} = M_i$, $M_{ij} = 0$ (M_i is the moment of inertia constant of the i -th generator). \mathbf{D} is an $n \times n$ matrix with entries D_{ii} : Damping coefficient concerning the i -th machine, $D_{ij} = 0$. \mathbf{K} is an $n \times n$ matrix with the following entries:

$$K_{ij} = E_i' E_j' (G_{ij} \sin(\delta_i - \delta_j) - B_{ij} \cos(\delta_i - \delta_j)) \quad (13)$$

$$K_{ii} = - \sum_{j=1, j \neq i}^n k_{ij} \quad (14)$$

C. Eigenvalues of the State Matrix and Analysis of Stability

According to the Lyapunov's first method, the small signal stability of a nonlinear dynamic system is given by the roots of the characteristic equation of the system of first approximation [8]. If this method is applied to the system depicted in Fig. 1,

then the eigenvalues of the state matrix (\mathbf{A}_{state}) can indicate the small signal stability in the following forms:

- The original system is asymptotically stable [9] when the eigenvalues have negative real parts [10].
- The original system is unstable if one eigenvalue has a positive real part [10].

III. ITERATIVE-STOCHASTIC METHOD TO ANALYZE THE SMALL SIGNAL STABILITY

Power systems operate under the restrictions derived from the non-storability of electrical energy [11]. The electrical energy produced and consumed throughout the system should be equal at each moment. From another viewpoint, production and consumption are not certain quantities. The uncertainty of electricity production increases when the application of renewable energy sources grows. Thus, the stability of power networks is affected by the stochastic nature of sustainable sources of energy. This section discusses the theory of an iterative-stochastic algorithm to analyze the small disturbance angle stability. Also, a qualitative discussion on this method is presented within this section.

A. Theory and Modeling

The iterative-stochastic algorithm, models the uncertainty of sustainable energy sources and the load behavior. Subsequently, for each sample of the load-generation set, a linear analysis is performed and the relevant eigenvalues are examined.

In this paper, a normal distribution [12] is used for modeling the loads. The consumed active power P_L is sampled based on a normal distribution with the mean value μ and the standard deviation σ , i.e., $P_L \sim N(\mu, \sigma)$. Considering the power factor of the load ($\cos \Phi_L$), the consumed reactive power is given by

$$Q_L = P_L \tan \Phi_L \quad (15)$$

In order to sample the stochastic power generation, this paper follows the pattern of wind turbines. The power generated by a wind turbine (provided that the upstream wind velocity, u , is between the minimal and the maximal values) can be expressed as [13], [14]

$$P = \frac{1}{2} C_p \rho u^3 A \quad (16)$$

With

$$C_p = \frac{1}{2} \left(1 + \frac{u_0}{u}\right) \left[1 - \left(\frac{u_0}{u}\right)^2\right] \quad (17)$$

Where P denotes the output power, C_p the power coefficient, u_0 the downstream wind velocity at the exit of rotor blades, ρ the air density and A the swept area of the rotor disc.

For modeling the wind speed, a Weibull distribution [15] is used. The obtained wind speed samples are inserted into equation (16) to have the samples of the generated active power.

The dependency of samples on each other in the sampling process influences the iterative-stochastic method. Although the loads follow the normal distribution independently, they

still can be correlated due to different reasons such as geographic differences or being the various load types. A similar reasoning is valid for generation sampling. For an instructive discussion on models of stochastic dependence, the reader is referred to [11] (Chapter 5). For the sake of simplicity, in this paper, loads are independently sampled, but to be more realistic, the sustainable generation, at different nodes, is correlated using the Gaussian copula [16].

B. Qualitative Discussion

The iterative-stochastic algorithm for each couple of (X : load, Y : generation), performs a linear analysis. If this method is applied to the power system depicted in Fig. 1, then for each couple, $2n$ eigenvalues should be evaluated. Since any eigenvalue with positive real part has to be avoided, it is possible to deal with $\max\{Re\{2n \text{ eigenvalues}\}\}$. Considering the fact that at least one eigenvalue will be zero [9], it is expected that for a stable system, the iterative-stochastic algorithm gives a number of zeros.

An important aspect of this method is that the power flow calculation has to be done for each couple of samples. To perform this power flow calculation, one node acts as a slack node. Due to the stochastic generation, direction of power flow may change and as a consequence, PQ nodes may participate in the net production. This affects the conventional PV nodes and/or the slack node. In other words, the reactive power consumption, i.e., negative generation, occurs for a synchronous generator (in underexcited mode) [17]. Also, obtaining a negative active power for the slack node may be the case (synchronous motor).

Sensitivity to the system parameters is another distinctive feature of this iterative-stochastic method. Equation (12) shows that the parameters which can affect the elements of the state matrix (\mathbf{A}_{state}), are important for the system stability. These parameters, based on equations (12)-(14), are:

- The moment of inertia constant of each machine.
- The damping coefficient of each machine.
- The adjustable elements of matrix \mathbf{K} , i.e., the internal voltage of the machines ($\bar{E}'_k = E'_k \angle \delta_k$), the conductance (G_{ij}) and the susceptance (B_{ij}) in the reduced network matrix.

IV. NUMERICAL EXAMPLE

In this section, a nine-bus test system depicted in Fig. 2 is used for demonstrating the iterative-stochastic algorithm. The simulations are performed by using MATLAB and all quantities are in per unit, unless otherwise stated. The conventional system data can be taken from [3] (pp. 38, 39).

The test system is modified by the installation of three local wind turbines at buses 5, 6 and 8 respectively. In order to investigate the effects of wind turbines and the time-continuous behavior of the loads some aspects of system data are adjusted in the following way.

- Demanded active power at bus 5: $P_{L5} \sim N(\mu = 1.25, \sigma = 0.4)$. Load power factor at bus 5: $\cos \Phi_{L5} = 0.9$.

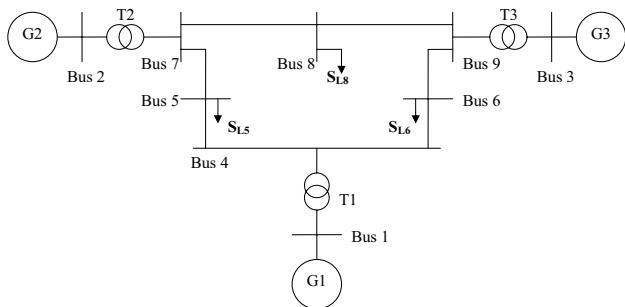

Fig. 2. A nine-bus test system

- Demanded active power at bus 6: $P_{L6} \sim N(0.9, 0.4)$. Load power factor at bus 6: $\cos \Phi_{L6} = 0.9$.
- Demanded active power at bus 8: $P_{L8} \sim N(1, 0.4)$. Load power factor at bus 8: $\cos \Phi_{L8} = 0.9$.

It is worth noticing that normally distributed loads may also include negative samples. To have a more accurate analysis, all possible negative samples are converted to zero.

- Damping coefficient of each generator is set to one.
- The stochastic generated active power at buses 5, 6 and 8 is modeled based on the equations (16) and (17). Power factor of generation is set to $\cos \Phi_G = 0.9$. Wind speed follows the Weibull distribution with scaling parameter $A = 13$ and shape parameter $K = 2$ [18]. Wind speed samples, for different buses, are correlated by the

correlation matrix $\rho = \begin{pmatrix} 1 & 0.8 & 0.6 \\ 0.8 & 1 & 0.7 \\ 0.6 & 0.7 & 1 \end{pmatrix}$. Also, wind

speed at nominal power: $u_N = 13 \frac{m}{s}$, nominal power: $P_N = 1.8$, cut in wind speed: $u_{ci} = 3 \frac{m}{s}$ and cut out wind speed: $u_{co} = 25 \frac{m}{s}$.

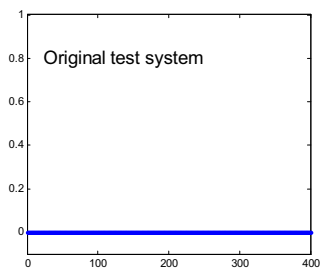

Fig. 3. Variation of the maximum real part of eigenvalues vs. samples.

Fig. 3 shows the distribution of small disturbance angle stability indicators for the above explained test system. According to Fig. 3, the system is at a high level of stability for the 400 analyzed samples.

It becomes now possible to check the sensitivity of the system angle stability to some controllable parameters. Fig. 4 shows how the system stability is influenced by the nominal power parameter (P_N) of the wind turbines when this is increased from 1.8 to 3. Based on Fig. 4, it can be concluded that the small disturbance angle stability of the system is jeopardized by increasing the parameter P_N for all wind turbines. Another controllable parameter, to which the small

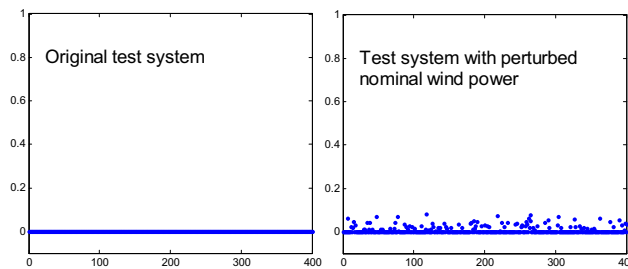

Fig. 4. Variation of the maximum real part of eigenvalues vs. samples.

disturbance angle stability of the system is highly sensitive, is the power factor of the stochastic generation ($\cos \Phi_G$). Decreasing this parameter from 0.9, in the original test system, to 0.4 for all of the PQ nodes can significantly lower the level of small disturbance angle stability. Fig. 5 shows that how the density of eigenvalues with positive real parts intensifies when the generation power factor decreases.

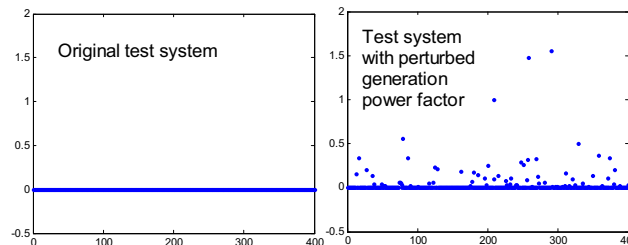

Fig. 5. Variation of the maximum real part of eigenvalues vs. samples.

Perhaps the least sensitivity of the small disturbance angle stability for such a test system is shown to the inertia constant of the synchronous machines. In other words, for the described system, connecting the synchronous machines with much larger inertia constants does not influence the pattern of eigenvalue distribution in a significant way. The same result holds if much lower inertia constants are present. Since the inertia constant is closely related to the weight, one could say that replacing heavier or lighter synchronous machines, does not significantly influence the small disturbance angle stability of the stated test system. Fig. 6 illustrates this when synchronous machines in the original system are replaced with ten times heavier ones (the inertia constants of the synchronous machines have been multiplied by a factor of 10). The increasing of the inertia constant has been simultaneously applied to all generators. In order to see the impact of only one heavy synchronous machine, Fig. 7 is of help. It shows the distribution of the maximum real part of the eigenvalues when the inertia constant of generator number 2 has been multiplied by 10.

This section discussed the sensitivity of a specific test system in relation to some types of system parameters. For example, within the investigation of sensitivity to the power factor of the generation, the applied change included all wind turbines. But, the iterative-stochastic approach, also, gives the possibility of performing a sensitivity analysis for a single individual parameter in the system. Although this method

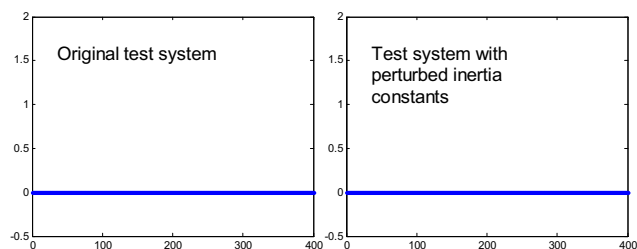

Fig. 6. Variation of the maximum real part of eigenvalues vs. samples.

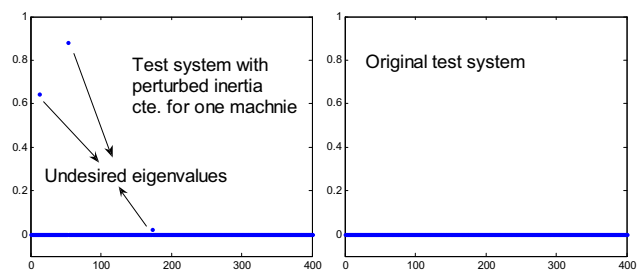

Fig. 7. Variation of the maximum real part of eigenvalues vs. samples.

can not consider the changes in the system configuration, it allows to perform a sensitivity analysis for the parameters of transmission lines. Thus, the impacts of resistive, reactive and capacitive effects of the lines on the small signal stability can also be investigated by this method.

V. CONCLUSION

It has been shown that an increased supply of renewable energy sources, gives a negative effect on the small disturbance angle stability of electric power systems. By introducing an iterative-stochastic algorithm, the uncertain nature of sustainable energy sources was considered in the small signal stability analysis. This method reconciled the stochastic behavior of renewable energy sources and the deterministic method of stability study.

Also, the trend of change in the indicators of small disturbance angle stability, i.e., the eigenvalues, was investigated. Eventually, the sensitivity of small disturbance angle stability to some system parameters was investigated for an electric power test system equipped with a number of renewable energy sources.

ACKNOWLEDGMENT

N. Farkhondeh acknowledges the financial support of the Energy Research Program of the Dutch Ministry of Economic Affairs. Also, he gratefully appreciates L. Hakobyan because of her useful technical assistance.

REFERENCES

[1] P. Kundur, J. Paserba, V. Ajarapu, G. Andersson, A. Bose, C. Canizares, N. Hatziargyriou, D. Hill, A. Stankovic, C. Taylor, Th. van Cutsem, V. Vittal, "Definition and Classification of Power System Stability", *IEEE Trans. on Power Systems*, Vol. 16, No. 2, May 2004.
[2] M. Ghandhari, "Control Lyapunov Functions: A control strategy for damping of power oscillations in large power systems", Ph.D. dissertation, The Royal Institute of Technology, TRITA-EES-0004, ISSN 1100-1607, 2000.

[3] P. M. Anderson, A. A. Fouad, *Power System Control and Stability: The Iowa State University Press*, 1977.
[4] J. J. Grainger, W. D. Stevenson, *Power System Analysis: McGraw-Hill*, 1994.
[5] N. Farkhondeh, G. Papaefthymiou, L. van der Sluis, "Survey on the Application of Chaos Theory to the Stability Analysis of Electric Power Systems", *Proceedings of the IEEE Young Researchers Symposium, Eindhoven, The Netherlands*, February 2008.
[6] Hsiao-Dong Chiang *et al.*, "Chaos in a Simple Power System", *IEEE Trans. on Power Systems*, Vol. 8, No. 4, November 1993.
[7] http://en.wikipedia.org/wiki/Taylor_series[online].
[8] A. M. Lyapunov, *Stability of Motion: Academic Press, Inc.*, 1967.
[9] P. A. Cook, *Nonlinear Dynamical Systems*, Second ed: Prentice Hall, Inc., 2004.
[10] P. Kundur, *Power System Stability and Control: McGraw-Hill*, 1994.
[11] G. Papaefthymiou, "Integration of Stochastic Generation in Power Systems", Ph.D. dissertation, Delft University of Technology, ISBN 978-90-8570-186-6, 2007.
[12] http://en.wikipedia.org/wiki/Normal_distribution [online].
[13] N. Jenkins. *et al.*, "Embedded Generation", *IEE Trans. on Power and Energy*, No. 31, 2000.
[14] J. G. Sootweg, "Wind Power: Modelling and Impact on Power System Dynamics", Ph.D. dissertation, Delft University of Technology, ISBN 90-9017239-4, 2003.
[15] <http://mathworld.wolfram.com/WeibullDistribution.html>[online].
[16] D. J. Erdman, A. Sinko, "Using Copulas to Model Dependency Structures in Econometrics", *SAS Global Forum*, Paper 321, 2008.
[17] P. Schavemaker, L. van der Sluis, *Electrical Power System Essentials: John Wiley and Sons, Ltd.*, 2008
[18] <http://www.windpower.org/en/tour/wres/weibull> [online].



Nima Farkhondeh Jahromi received his M.Sc. degree in electric power engineering from The Royal Institute of Technology (KTH), Stockholm, Sweden in 2006. He is currently working towards a Ph.D. at The Delft University of Technology (TU-Delft), Delft, The Netherlands.



George Papaefthymiou obtained his Dipl-Eng. degree in Electrical and Computer Engineering from the University of Patras, Greece in 1999 and the Ph.D. degree from the Delft University of Technology in 2007. He is currently with both Ecofys, Berlin and the Electrical Power Systems Laboratory of the Delft University of Technology.



Lou van der Sluis obtained his M.Sc. in electrical engineering from The Delft University of Technology in 1974. He joined the KEMA High Power Laboratory in 1977. In 1990 he became a part-time professor and since 1992 he has been employed as a full-time professor at The Delft University of Technology in The Power Systems Department.