

Characterization of Indoor Power lines As Data Communication Channels Experimental Details and Results

Sheroz Khan, A. F. Salami, W. A. Lawal, AHM Zahirul Alam, Shihab Abdel Hameed, and M. J. E. Salami

Abstract—In this paper, a multi-branch power line is modeled using ABCD matrix to show its worth as a communication channel. The model is simulated using MATLAB in an effort to investigate the effects of multiple loading, multipath, and those as a result of load mismatching. The channel transfer function is obtained and investigated using different cable lengths, and different number of bridge taps under given loading conditions.

Keywords—Power line Communication, Transfer Function, Channel Modeling, Signal Transmission.

I. INTRODUCTION

THE use of power line as a broadband communication channel has been the focus of researchers since very long. One way of modeling power line as a communication channel is addressed in [1], where its transfer function for the multipath communication is derived using the chain matrix method. In order to ascertain this transfer function, the author used parameters like propagation constant and characteristic impedance in a lumped-element circuit model by approximating the channel as a two-wire transmission medium. In another approach the power line is modeled as a communication channel with two customary parameters, namely, characteristic impedance and propagation constant using the lumped-element circuit model once again [2]. Here the authors have derived the transfer function for an N-branch power line communication channel based on the scattering matrix method. In [3], the problem of determining the exact conditions under which the power line communication is investigated for its symmetry as a communication channel. The authors modeled the power line communication channel using transmission matrices and proved that the only condition is the requirement that the source and load impedances are the same. In [4], the authors experimentally measured the power line communication parameters and obtained the channel transfer function for actual cables and the results correlated with the theoretical assumptions underlying power line channels. In [5], the author measured, analyzed and modeled the characteristic of individual industrial low voltage network components and pilot environments.

Authors are with IIUM, Malaysia. e-mail: sheroz@iiu.edu.my

The author also developed and tested narrow-band power line communication channels.

In this paper, a multi-branch power line communication channel is modeled using ABCD matrix which is then simulated using MATLAB. The effects of multiple loads, multipathing and mismatching are also investigated in this work. The channel transfer function is obtained and investigated using a given number of cable lengths, and with known number of bridge taps and given loading conditions.

II. SIMPLE POWER LINE MODEL

The transfer function of the power line communication channel is generally modeled using the chain matrix theory also known as the ABCD matrix theory. Using this theory, a communication channel represented as a two port channel can be described using an ABCD matrix.

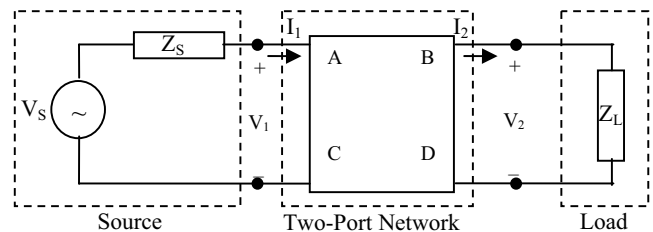

Fig. 1 Simple Power Line Model

This provides a convenient way for determining the transfer function of the channel. For a simple power line communication model as shown in Fig. 1, the relationship between the input current I_1 , input voltage V_1 , output current I_2 and output voltage V_2 can be represented using the following expression:

$$\begin{bmatrix} V_1 \\ I_1 \end{bmatrix} = \begin{bmatrix} A & B \\ C & D \end{bmatrix} \begin{bmatrix} V_2 \\ I_2 \end{bmatrix} \quad (1)$$

The parameters A, B, C and D are frequency dependent components. The above expression can be easily used to calculate useful quantities such as the input impedance and the transfer function of the communication channel.

Input Impedance: being the ratio of the input voltage of the channel to the input current of the channel, this is given by.

$$Z_{in} = \frac{V_1}{I_1} \quad (2)$$

Where V_1 and I_1 are to be determined from (1) as:

$$V_1 = AV_2 + BI_2 \quad (3)$$

$$I_1 = CV_2 + DI_2 \quad (4)$$

Substituting equations (3) and (4) in (2) results in

$$Z_{in} = \frac{V_1}{I_1} = \frac{AV_2 + BI_2}{CV_2 + DI_2} \quad (5)$$

Dividing the numerator and denominator of (5) by I_2 and

substituting $\frac{V_2}{I_2}$ with Z_L results in,

$$Z_{in} = \frac{AZ_L + B}{CZ_L + D} \quad (6)$$

Transfer Function: The transfer function is the ratio of the output to the input of the channel. The output is the voltage V_L across the load while the input is supply voltage V_s .

$$H = \frac{V_L}{V_s} \quad (7)$$

From Fig.1, it is easy to infer that,

$$V_L = V_2 = I_2 Z_L \quad (8)$$

$$V_s = I_1 Z_s + V_1 \quad (9)$$

Equation (9) can be simplified further by substituting I_1 and V_1 with (3) and (4), this results in,

$$\begin{aligned} V_s &= (CV_2 + DI_2)Z_s + AV_2 + BI_2 \\ &= (CI_2 Z_L + DI_2)Z_s + AI_2 Z_L + BI_2 \end{aligned} \quad (10)$$

Substituting the values of V_L and V_s in (7) gives

$$H = \frac{I_2 Z_L}{CI_2 Z_L Z_s + DI_2 Z_s + AI_2 Z_L + BI_2} \quad (11)$$

This simplifies to

$$H = \frac{Z_L}{AZ_L + B + CZ_L Z_s + DZ_s} \quad (12)$$

Insertion Loss: Similarly the insertion loss can be computed as:

$$H_{il} = \frac{Z_L + Z_s}{Z_L} H \quad (13)$$

$$H_{il} = \frac{Z_L + Z_s}{AZ_L + B + CZ_s Z_L + DZ_s} \quad (14)$$

The ABCD matrix of a transmission line with length l , characteristic impedance Z_C and propagation constant γ is given as

$$\begin{bmatrix} A & B \\ C & D \end{bmatrix} = \begin{bmatrix} \cosh(\gamma l) & Z_c \sinh(\gamma l) \\ 1/Z_c \sinh(\gamma l) & \cosh(\gamma l) \end{bmatrix} \quad (15)$$

The characteristic impedance Z_C , and propagation constant γ of the communication channel can be computed from the per-unit length parameters of the cable as

$$\gamma = \sqrt{(R + j\omega L)(G + j\omega C)} \quad (16)$$

$$Z_c = \sqrt{\frac{R + j\omega L}{G + j\omega C}} \quad (17)$$

Where

R – Resistance in per unit length (Ω/m) of both conductors.

L – Inductance in per unit length (H/m) of both conductors.

G – Conductance in per unit length (S/m) of insulating material used.

C – Capacitance in per unit length (C/m) between the conductors.

With the knowledge of the per-unit length parameters of the transmission line and the ABCD matrix, it is easy to compute transfer function of the transmission line using equation (14).

III. POWER LINE MODEL WITH BRIDGE TAPS

However power line communication systems do not usually consist of simply a source, transmission line and a load as depicted in figure 1. Bridge taps with different cable lengths and cable types usually exists along the transmission line to form a power line network made of sections.

For a power line communication network with several sections, the transfer function for the whole network is still the same as equation (12); however, the ABCD matrix for the system differs. The ABCD matrix is determined by utilizing the chain rule which involves multiplying the ABCD matrices for the different sections of the network to produce the overall ABCD matrix.

While the ABCD matrix for a transmission line is give in equation (15), the ABCD matrix for a serially connected load Z_s is [5]:

$$\begin{bmatrix} A & B \\ C & D \end{bmatrix} = \begin{bmatrix} 1 & Z_s \\ 0 & 1 \end{bmatrix} \quad (18)$$

and the ABCD matrix for a load impedance Z_p connected in parallel is:

$$\begin{bmatrix} A & B \\ C & D \end{bmatrix} = \begin{bmatrix} 1 & 0 \\ 1/Z_p & 1 \end{bmatrix} \quad (19)$$

A bridge tap terminated with load impedance Z can be considered to be equivalent to impedance Z_{eq} calculated as:

$$Z_{eq} = Z_c \frac{Z + Z_c \tanh(\gamma_{br} l_{br})}{Z_c + Z \tanh(\gamma_{br} l_{br})} \quad (20)$$

where Z_c and γ_{br} are the characteristic impedance and the propagation constant of the branch circuit respectively.

Consider the transmission line with one bridge tap connection as shown in Fig. 2 which can be replaced by an equivalent network shown in Fig. 3 where Z_{eq} is calculated using equation (20).

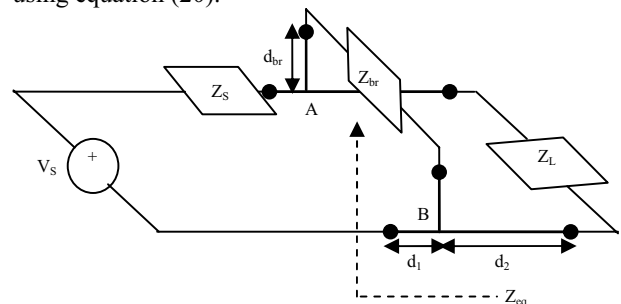

Fig. 2 Transmission Line with Bridge Tap Connection

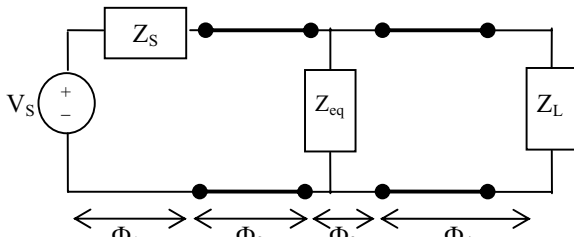

Fig. 3 Equivalent Network for Bridge Tap Connection

A power line network of Fig. 3 can be partitioned to four sub-circuits denoted by Φ_0 , Φ_1 , Φ_2 and Φ_3 . It can be noted that sub-circuit Φ_0 is a serially connected load, sub-circuits Φ_1 and Φ_3 are transmission line sections while Φ_2 is a load impedance in parallel.

Hence, the ABCD matrix for the transfer function is calculated as:

$$\phi_0 = \begin{bmatrix} 1 & Z_s \\ 0 & 1 \end{bmatrix}, \phi_1 = \begin{bmatrix} \cosh(\gamma_1 d_1) & Z_1 \sinh(\gamma_1 d_1) \\ \frac{1}{Z_1} \sinh(\gamma_1 d_1) & \cosh(\gamma_1 d_1) \end{bmatrix},$$

$$\phi_2 = \begin{bmatrix} 1 & 0 \\ \frac{1}{Z_{eq}} & 1 \end{bmatrix}, \phi_3 = \begin{bmatrix} \cosh(\gamma_2 d_2) & Z_2 \sinh(\gamma_2 d_2) \\ \frac{1}{Z_2} \sinh(\gamma_2 d_2) & \cosh(\gamma_2 d_2) \end{bmatrix}$$

$$\begin{bmatrix} A & B \\ C & D \end{bmatrix} = \prod_{i=0}^3 \phi_i = \phi_0 \phi_1 \phi_2 \phi_3$$

$$= \begin{bmatrix} 1 & Z_s \\ 0 & 1 \end{bmatrix} \begin{bmatrix} \cosh(\gamma_1 d_1) & Z_1 \sinh(\gamma_1 d_1) \\ \frac{1}{Z_1} \sinh(\gamma_1 d_1) & \cosh(\gamma_1 d_1) \end{bmatrix}$$

$$\begin{bmatrix} 1 & 0 \\ \frac{1}{Z_{eq}} & 1 \end{bmatrix} \begin{bmatrix} \cosh(\gamma_2 d_2) & Z_2 \sinh(\gamma_2 d_2) \\ \frac{1}{Z_2} \sinh(\gamma_2 d_2) & \cosh(\gamma_2 d_2) \end{bmatrix}$$

where Z_1 , γ_1 , Z_2 , and γ_2 are the characteristic impedances and propagation constants for the second and fourth sub-circuits. Given the value of the ABCD matrix, the transfer function of the power line can be computed easily. However, as the number of bridge taps increases, the complexity involved and the formula for calculating the ABCD matrix increases in size.

IV. ANALYSIS AND RESULTS

Analytical results are obtained by modeling different power line communication channels using different cable lengths, different number of bridge taps and different loading conditions. All cables used in the model are considered to have RLG parameters, $R = 1.9884\Omega/m$, $G = 0.01686nS/m$, $C = 0.13394nF/m$, $L = 362.81nH/m$. The channel models are realized by using MATLAB scripts to code the channel parameters and equations. The transfer function plots for the different configurations are shown between the frequency bands 0Hz - 30MHz.

A. Power line model with different load matching conditions

No bridge tap conditions were used in these power line communication channel model, the cable lengths are kept constant while the effect a load impedance at the end of the transmission line model which is improperly matched with that of the source impedance, is investigated. The transfer plots shown in Fig. 4 and Fig. 5 are showing almost

symmetrical patterns as they are for a power line under similar conditions except the load and the source impedances are swapped.

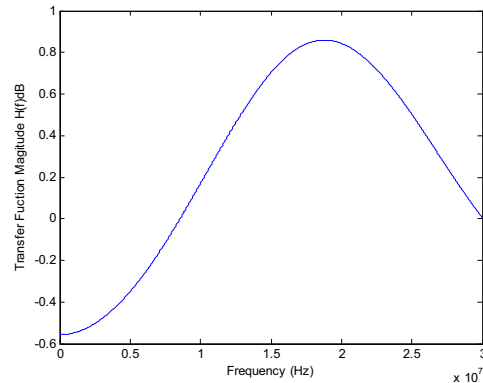

Fig. 4 Transfer Function Plot of Power Line Model with $Z_s = 0$ and $Z_L = 60\Omega$ (cable length 2m)

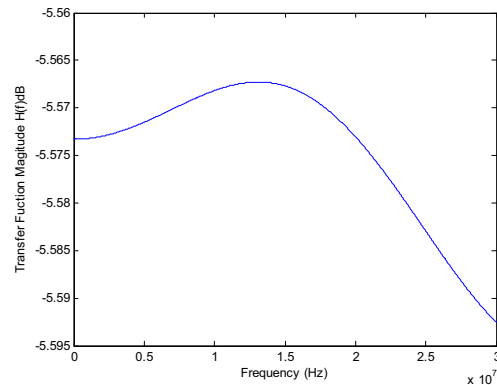

Fig. 5 Transfer Function Plot for Power Line Model with $Z_s = 50\Omega$ and $Z_L = 60\Omega$ (cable length 2m)

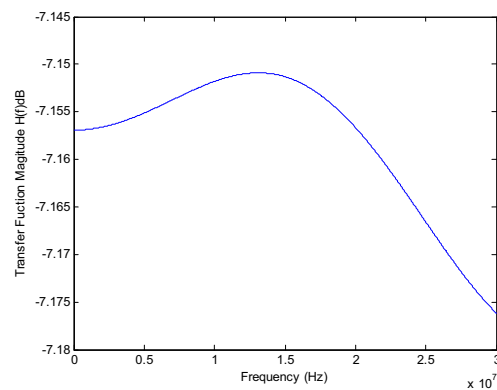

Fig. 6 Transfer Function Plot for Power Line Model with $Z_s = 60\Omega$ and $Z_L = 50\Omega$ (cable length 2m)

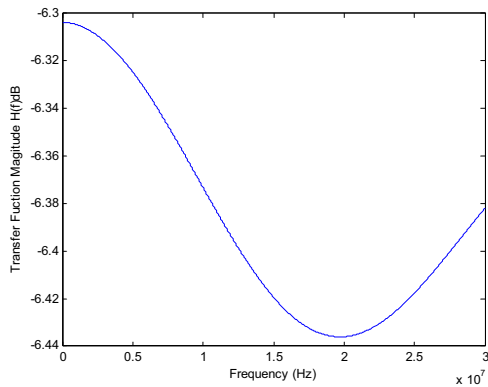

Fig. 7 Transfer Function Plot for Power Line Model with $Z_s = 60\Omega$ and $Z_L = 60\Omega$ (cable length 2m)

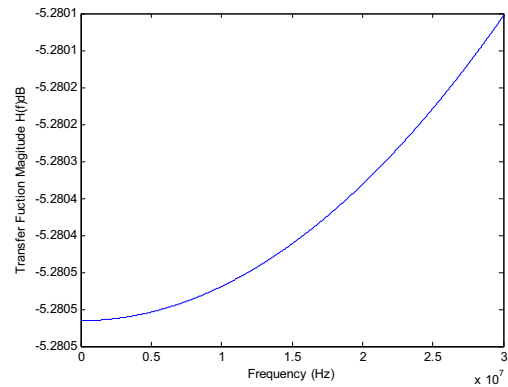

Fig. 9 Transfer Function Plot for Power Line Model with cable length, $d = 0.1\text{m}$ (No bridge taps), $Z_s = 50\Omega$, $Z_L = 60\Omega$

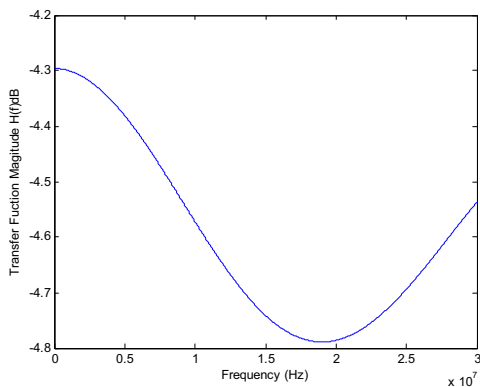

Fig. 8 Transfer Function Plot for Power Line Model with $Z_s = 60\Omega$ and $Z_L = 100\Omega$ (cable length 2m)

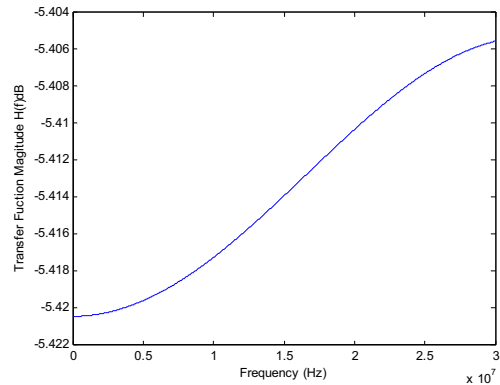

Fig. 10 Transfer Function Plot for Power Line Model with cable length, $d = 1\text{m}$ (No bridge taps), $Z_s = 50\Omega$, $Z_L = 60\Omega$

From figures 4 to 8, it can be deduced that as the input impedance, Z_s increases, the attenuation increases provided the load impedance, Z_L is kept constant. On the other hand, as the load impedance, Z_L increases, the attenuation gradually decreases provided the input impedance, Z_s is kept constant.

B. Power line model with different cable lengths

Transfer function for two different power line configurations is tested here. The first configuration investigates the effects of cable lengths on a transmission line model without bridge taps while the second configuration investigates the same effects with the presence of bridge taps under similar loading conditions shown in Fig.9 until Fig. 15.

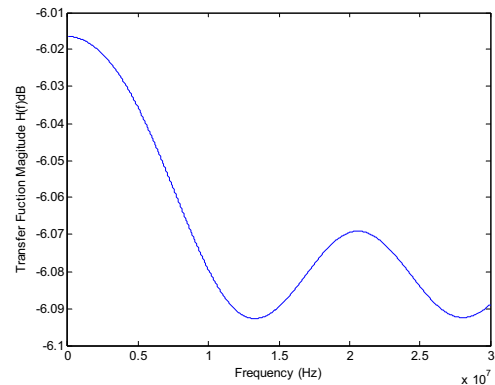

Fig. 11 Transfer Function Plot for Power Line Model with cable length, $d = 5\text{m}$ (No bridge taps), $Z_s = 50\Omega$, $Z_L = 60\Omega$

From figures 9 to 11, it can be deduced that as the cable length increases the attenuation gradually increases. This can be justified with the fact that with longer cable lengths, the signal will be exposed to interference, hence, the signal strength will gradually decrease over the distance.

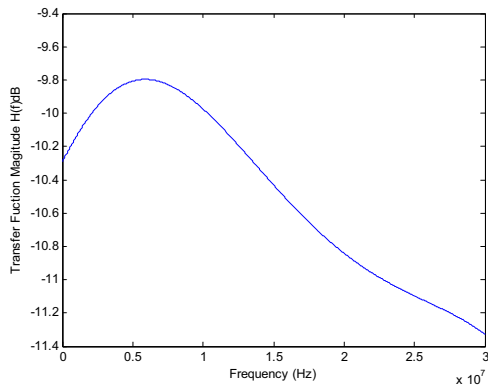

Fig. 12 Transfer Function Plot for Power Line Model with total cable length 2m and bridge tap length 1m with branch impedance $50 + j100 \Omega$, $Z_s = 50\Omega$, $Z_L = 60\Omega$

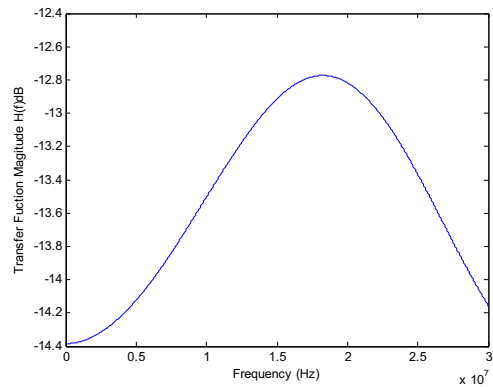

Fig. 15 Transfer Function Plot for Power Line Model with total cable length 4m and bridge tap length 2m with branch impedance 50Ω , $Z_s = 50\Omega$, $Z_L = 50\Omega$

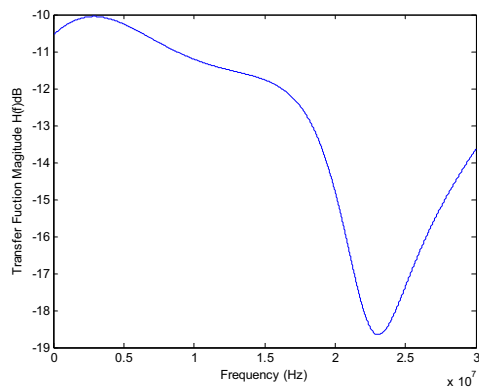

Fig. 13 Transfer Function Plot for Power Line Model with total cable length 4m and bridge tap length 2m with branch impedance $50 + j100 \Omega$, $Z_s = 50\Omega$, $Z_L = 60\Omega$

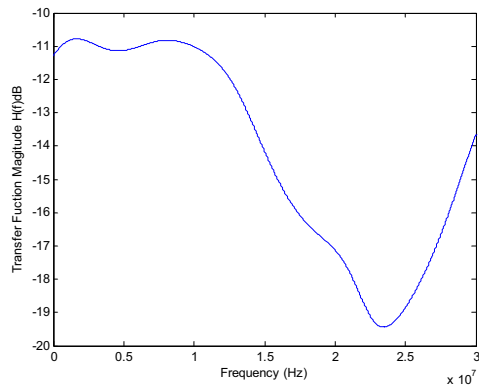

Fig. 14 Transfer Function Plot for Power Line Model with total cable length 10m and bridge tap length 2m with branch impedance $50 + j100 \Omega$, $Z_s = 50\Omega$, $Z_L = 60\Omega$

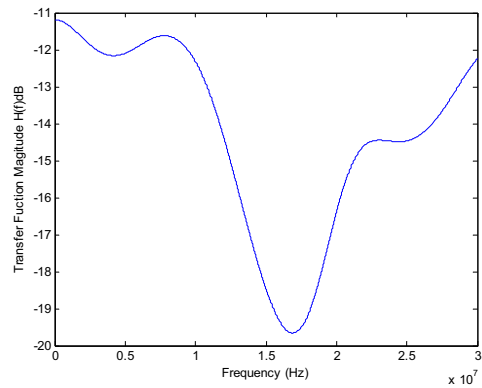

Fig. 16 Transfer Function Plot for Power Line Model with total cable length of 10m and single bridge tap of impedance 200Ω and bridge tap length 2m, $Z_s = 50\Omega$, $Z_L = 60\Omega$

From figures 12 to 15, it can be deduced that a longer bridge length on the communication line will significantly increase the attenuation when compared to the scenarios without bridge taps. This can be justified with the fact that bridge taps are acting as interference and the longer the bridge tap length, the stronger the effect of the interference. Hence, longer bridge taps will weaken the signal on the communication line.

C. Power line model with different bridge tap conditions

The different bridge tap conditions investigated include a power line communication channel with single bridge tap, three bridge taps and five bridge taps. The input and output impedance for all models are kept constant while the cable length and bridge tap loads are varied.

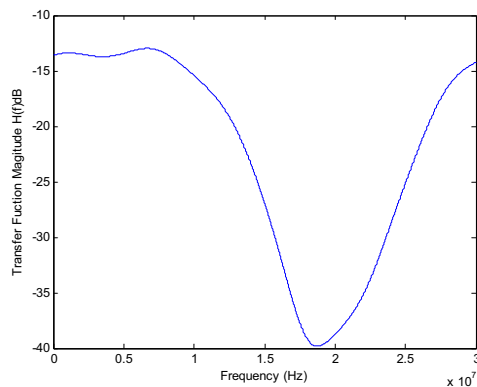

Fig. 17 Transfer Function Plot for Power Line Model with total cable length of 10m and 3 bridge taps of impedance $50 + j100 \Omega$, 150Ω , 450Ω and bridge tap lengths 2m, 2m, 2m, $Z_s = 50 \Omega$, $Z_L = 60 \Omega$

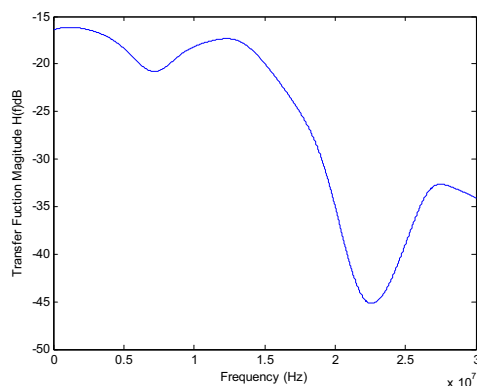

Fig. 18 Transfer Function Plot for Power Line Model with total cable length of 10m and 5 bridge taps of impedance $50 + j100 \Omega$, 150Ω , 450Ω , $100 + j50 \Omega$, 200Ω and bridge tap lengths 2m, 5m, 1m, 2m, 1m, $Z_s = 50 \Omega$, $Z_L = 60 \Omega$

From figures 16 to 18, it can be deduced that as the number of bridge taps increases, the attenuation significantly and rapidly increases. Multiple bridge taps with varying length means multiple interference having varying strengths. Out of all cases, the scenario where there is multiple bridge taps have the most pronounced effect on the attenuation showing that the number of bridge taps is a strong determinant of signal attenuation.

V. DISCUSSION

The plots in figures 4 to 18 show the effects of channel length, bridge taps and load impedance on the transfer function plot of the power line communication channel. From

these plots, the effects of these quantities on the attenuation can be clearly seen. The analysis shows that the attenuation of the power line increases as the channel length and the number of bridge taps increases. The type of load impedance connected to the transmission line and the bridge taps is also seen to have considerable effects on attenuation especially in determining the shape of the plot. It can also be logically assumed that as the number of bridge taps increases, it is likely that the channel length and the total bridge tap length increases. This results in the further degradation of the transmission line as a result of increased cable length.

VI. CONCLUSION

In this paper the modeling of a simple power line communication channel and a multi-branch power line communication channel is thoroughly explained using the ABCD matrix approach. The transfer function model of the communication channel is simulated using MATLAB and the effect of using different loading conditions, cable lengths and number of bridge taps on the efficiency of the communication channel model is investigated. The results from the analysis show that increasing the cable length of the communication channel and number of bridge taps results in increased attenuation of the communication channel.

REFERENCES

- [1] Francis Berrysmith, "A Multi-Path Model For The Power Line Channel", Department of Electrical and Computer Engineering, University of Auckland, Auckland, New Zealand.
- [2] H. Meng, S. Chen, Y. L. Guan, C. L. Law, P. L. So, E. Gunawan, T. T. Lie, "Modeling of Transfer Characteristics for the Broadband Power Line Communication Channel", IEEE Transactions On Power Delivery, Vol. 19, No. 3, July 2004
- [3] T.C. Banwell, S. Galli, "On The Symmetry Of The Power Line Channel", IEEE International Symposium on Power Line Communications and its Applications, ISPLC01, Malmo, Sweden, April 4-6, 2001
- [4] Tooraj Esmailian, Frank R. Kschischang and P. Glenn Gulak, "In-building Power Lines As High-Speed Communication Channels: Channel Characterization And A Test Channel Ensemble", International Journal Of Communication Systems, Int. J. Commun. Syst. 2003; 16:381-400.
- [5] Jero Ahola, "Applicability Of Power-Line Communications To Data Transfer Of On-Line Condition Monitoring Of Electrical Drives", Lappeenranta University of Technology, Lappeenranta, Finland, August 2003.