

System Identification and Control the Azimuth Angle of the Platform of MLRS by PID Controller

Parkpoom Ch., Narongkorn D.

Abstract—This paper presents the system identification by physical's law method and designs the controller for the Azimuth Angle Control of the Platform of the Multi-Launcher Rocket System (MLRS) by Root Locus technique. The plant mathematical model was approximated using MATLAB for simulation and analyze the system. The controller proposes the implementation of PID Controller using Programmable Logic Control (PLC) for control the plant. PID Controllers are widely applicable in industrial sectors and can be set up easily and operate optimally for enhanced productivity, improved quality and reduce maintenance requirement. The results from simulation and experiments show that the proposed a PID Controller to control the elevation angle that has superior control performance by the setting time less than 12 sec, the rise time less than 1.6 sec., and zero steady state. Furthermore, the system has a high over shoot that will be continue development.

Keywords—Azimuth angle control, PID Controller, The platform of Multi-Launcher Rocket System.

I. INTRODUCTION

THIS paper is research and development the platform of the Multi-Launcher Rocket System in the Mechanical and Aeronautical Engineering Laboratory, Defence Technology Institute of Thailand. In the process of designing the controller of the azimuth angle of the platform of Multi-Launcher Rocket System, first step we have to identify the system [2, 3] by the physical's law. Then, simulation using MATLAB [4] and the Root Locus Technique for design the controller [1, 5]. The controller proposes the implementation of PID Controller that is widely applicable in industrial sectors and can be set up easily and operate optimally for enhanced productivity, improved quality and reduce maintenance requirement. The programming of the PLC using the brand is OMRON and CX-Programmer for create the program of controller. Finally, check the results and discussed on their performances. This paper was organized in the following manner: Section II describes the plant used; Section III describes model of system; Section IV describes controller design; Section V is on results and discussion; and finally, Section VI is the conclusions.

II. PLATFORM

The plant used in this researching is the platform of the Multi-Launcher Rocket System (MLRS) as shown in Fig. 1,2. The platform consists of six major parts as following:

Narongkorn Dernlugkam is with Defence Technology Institute (Public Organisation), Thailand email:narongkorn.d@dti.or.th

(i) The rocket pod has the dimension of 265mm, 1380mm and 195 mm in width, length and thickness respectively, (ii) The rocket pod supporting has dimension of 1000mm, 1380mm and 230 mm in width, length and thickness respectively, (iii) The base has dimension of 1050mm, 1110mm. and 360 mm in width, length and thickness respectively, (iv) The cylinder is a bidirectional cylinder type of brand name *Rexroth* model CDL1MP5. The piston diameter is 63mm, piston rod diameter 36mm, stroke 200mm, and piston area ratio 1.75:1. (v) The pressurized fluid flow is control by electronic control valve of brand name *Yuken*. This control valve is the proportional and directional type. The valve input voltage is $\pm 10V$ dc with current range (4-20) mA. (vi) The pressurized pump and hydraulic motor are regulate fluid source of up to 2300 psi or 160 bars. (vii) The controller of azimuth and elevation angles by the Programmable Logic Controller (PLC) and (viii) The fire control system which gains all information such as meteorology data, target coordinates and rocket position and orientation for computing the azimuth and elevation angles in order to send to PLC for set up the rocket launcher.

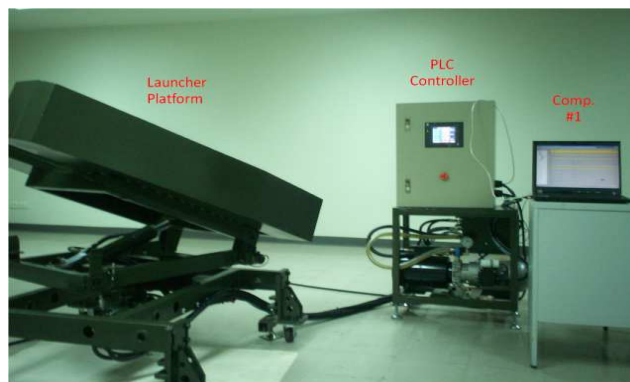

Fig. 1 The Platform of MLRS

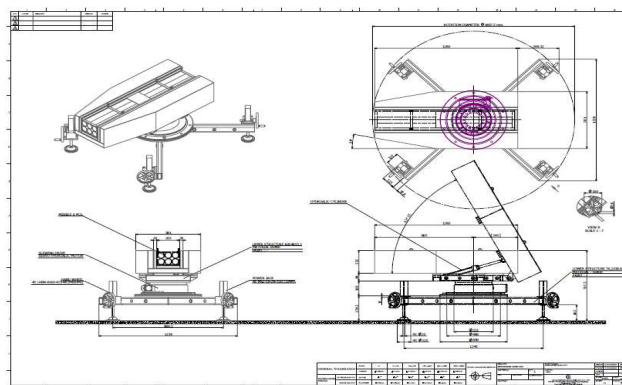

Fig. 2 2D Drawing of the MLRS Platform

III. MODEL OF SYSTEM

The model of the Azimuth Angle Controller consists of Controller, Valve, Motor hydraulic, and Plant of azimuth angle control as shown in Fig.3 and this system can explain in block diagram as shown in Fig.4.

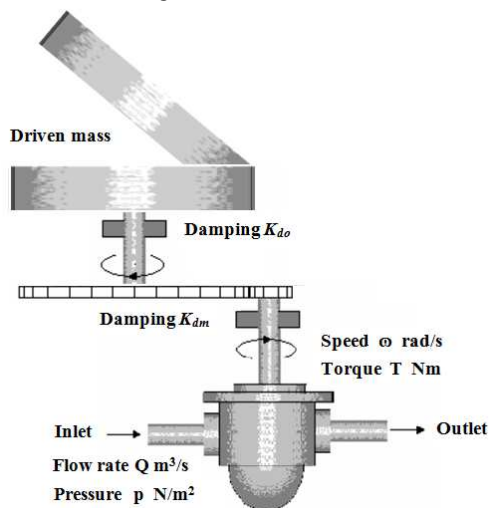

Fig. 3 Motor Hydraulic with the plant

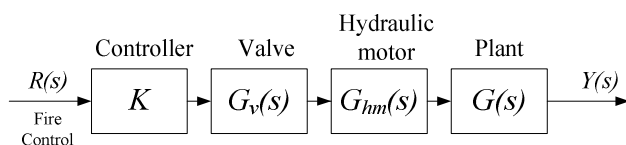

Fig. 4 Block diagram of the open loop model

Modeling of the system approximated by linearly system and single input single output (SISO). Using the physical law to determine the open loop transfer function of the system as following, The input to the system is the movement of the valve x_i through the valve constant k_v , and allows a flow Q m^3/s which makes the motor hydraulic for rotation.

$$Q = k_v x_i \quad (1)$$

From Fig.3 the formula relating flow rate Q and speed of rotation ω in radian. Written as a formula as below.

$$Q = k_q \omega = k_q \frac{d\theta}{dt} \quad (2)$$

k_q is a constant of nominal displacement with units of m^3 per radian. θ is the angle of rotation in radian. Written as a function of s-domain becomes

$$Q = k_q s \theta \quad (3)$$

Thus, the flow rate as the input and the angle of rotation as the output the transfer function of hydraulic motor is

$$G_{hm}(s) = \frac{\theta}{Q} = \frac{1}{k_q s} \quad (4)$$

Then, added the transfer function of the plant that consists of a gear set ratio 80:10 and a movement to the angle of

rotation in degree. Thus, the transfer function of the Azimuth Angle Controller is,

$$G(s) = \frac{1}{k_q s} \cdot \frac{180}{\pi} \quad (5)$$

From Eq.(5) situation the value of the plant, valve constant. So, the transfer function of the system as bellow.

$$G(s) = \frac{1}{2.24 s} \quad (6)$$

Where,

- Q Flow of oil into the cylinder (m^3/s)
- k_v Valve constant (m^2/s)
- x_i Distance of the movement of valve (m)
- k_q Nominal displacement constant (m^3/rad)

IV. CONTROLLER DESIGN

From Eq.(6) is the first order system, and the result of simulation by a unit step that is excited the open loop system. The result is unstable, because the result always increase after excited by unit step signal as shown in Fig.5 and check a root locus of the open loop system found that the system has a pole at zero that so nearly to unstable as shown in Fig.6

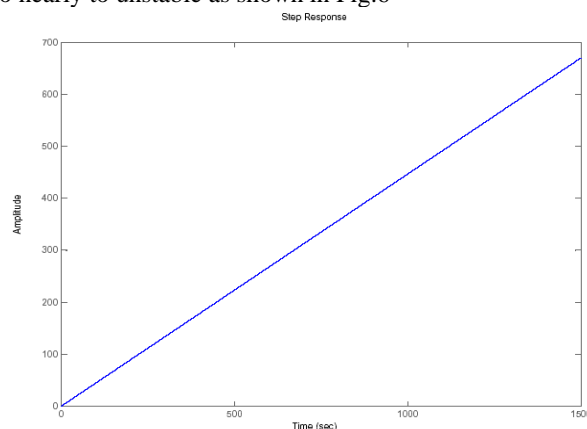

Fig. 5 Step response of the open loop system

Follow as the results of the open loop system. This research proposed the PID Controller to design the controller and using the Root Locus Technique for analyze the system.

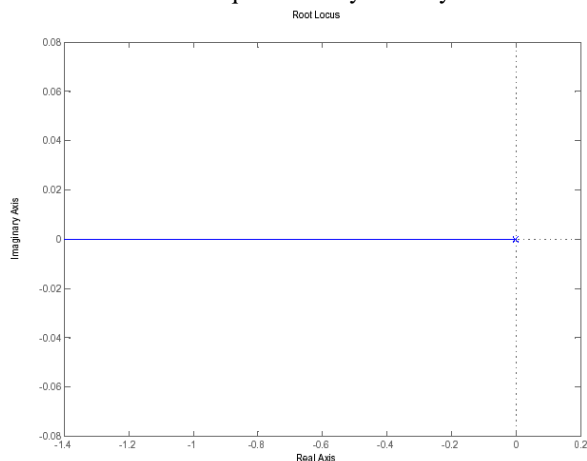

Fig. 6 Root locus of the open loop system

The PID Controller contains three parts that are contain the P-Proportional, I-Integral, and D-Derivative as shown in the block diagram in Fig.7. The system is a closed-loop control with PID Controller. The PID Controller is designed to determine the parameters of the appropriate control for the system's response and behavior, according to the stability of the system, setting time, and the steady state error.

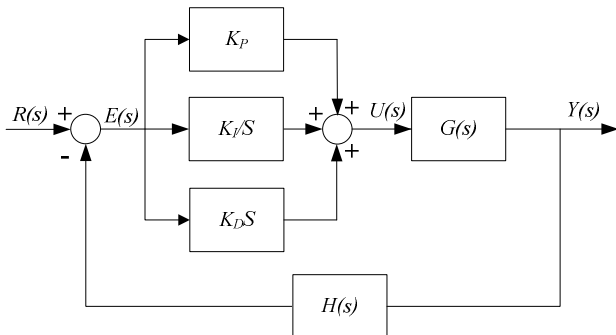

Fig. 7 Block diagram of the PID Controller

From the block diagram in Fig.7 the PID Controller is satisfy the following equation.

$$u(t) = K_p e(t) + K_I \int e(t) dt + K_D \frac{de(t)}{dt} \quad (7)$$

Then, transfers to the S-domain by Laplace transform as below.

$$U(s) = (K_p + \frac{K_I}{s} + K_D s) E(s) \quad (8)$$

Thus, determine the transfer function of the PID Controller,

$$K(s) = \frac{U(s)}{E(s)} = (K_p + \frac{K_I}{s} + K_D s) \quad (9)$$

When use the PID Controller to improve the existing system, additional the transfer function of the PID Controller to the system and there is the open loop transfers function as below.

$$K(s)G(s) = (K_p + \frac{K_I}{s} + K_D s) \frac{1}{(s+a)} \quad (10)$$

$$= \frac{K_D s^2 + K_p s + K_I}{s(s+a)} \quad (11)$$

Thus, the closed-loop transfer function as below.

$$\frac{Y(s)}{R(s)} = \frac{K(s)G(s)}{1 + K(s)G(s)} \quad (12)$$

$$= \frac{K_D s^2 + K_p s + K_I}{(K_D + 1)s^2 + (K_p + a)s + K_I} \quad (13)$$

From Eq. (12) the feed-back control by PID Controller is the additional two zeros and two poles in the open loop system to improve the setting time and Transient response. As the target of design is the setting time less than 10 sec. and the steady state error less than 1%. Follows a requirements,

designed the controller at and $K_I=4, K_p =2, K_D=1$. So the additional zero at $K_I/K_p=2$ and situation in Eq.(13). Then the transfer functions of closed-loop system as shown in Eq.(14). This the closed loop system has two poles at $p= -0.500 \pm 1.322i$, and a zero at $z= -1 \pm 1.732$, then analyze the Root Locus as shown in Fig.8

$$\frac{Y(s)}{R(s)} = \frac{K(s)G(s)}{1 + K(s)G(s)} = \frac{s^2 + 2s + 4}{4.48s^2 + 4.48s + 8.96} \quad (14)$$

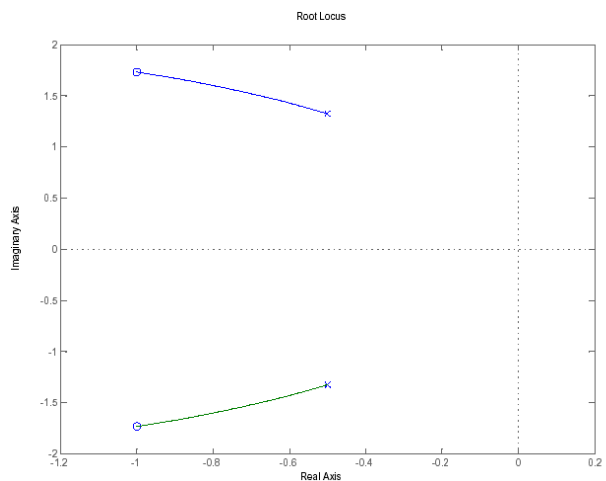

Fig. 8 Root locus of the closed loop system

Finally, setting the parameters of PID Controller by PLC and using the CX-Programmer is one of the software used for this project as shown in Fig.9. This software will enable the communication between the hardware which are the platform of Multi-Launcher Rocket System and the PLC in order to control the Elevation Angle of the platform.

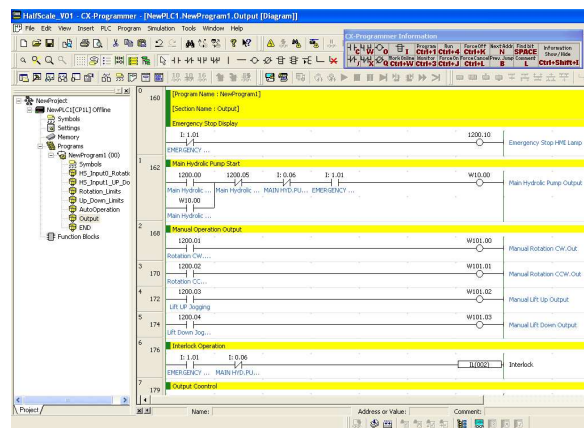

Fig. 9 CX-Programmer

V. RESULTS AND DISCUSSIONS

The simulation results using MATLAB to analyze the unit step response as shown in Fig.10. This closed-loop system of PID Controller for control The Azimuth Angle of the platform has a setting time 12 sec. and steady state error is zero that met for the requirements. But there is high overshoot on the first time which have to development in the next step.

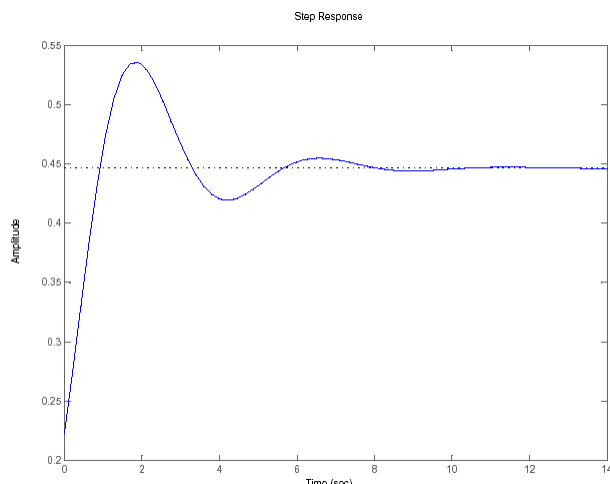

Fig. 10 Step response of the closed loop system



Mr. Narongkorn Dernlugkam received the bachelor's degree in Electrical Engineering from The Khon Kaen University, Khon Kaen, Thailand. With skill excellent in electrical power and Control System. He is a Platform and control system Researcher at Defence Technology Institute (Public Organization), Bangkok, Thailand. His current research interests are in the area of controlled mechanical systems, dynamic optimization and special software hardware design.

VI. CONCLUSIONS

The modeling by physical law method and designs the controller for control the azimuth angle of the platform of the Multi-Launcher Rocket System by Root Locus technique. After the model was approximated and analyze result of system and design the controller for control this system to meet the requirements. The controller proposes the implementation of PID Controller using PLC. A significant improvement in the system performance has been achieved with PID controller as setting the parameter $K_p = 2$, $K_I = 4$, $K_D = 1$. The simulation and analyze the results of the system found that met to requirements by the setting time less than 10 sec. and the steady state error is zero. But there is high overshoot that have to development in the next step.

ACKNOWLEDGMENT

This work is supported by Mechanical and Aeronautical Engineering Department, Research & Development Division, Defence Technology Institute of Thailand.

REFERENCES

- [1] Norman S. Nise, *Control System Engineering*, Sixth edition, John Wiley & Sons Inc., USA, pp. 663-722.
- [2] David T. Westwick and Robert E. Kearney, 2003, *Identification of Nonlinear Physiological Systems*, John Wiley & Sons Inc., USA.
- [3] Lennart Ljung, 2009, *System Identification Theory for the user*, Second edition, Prentice Hall PTR, USA.
- [4] Ashish Tewari, 2003, *Modern Control Design with Matlab Simulink*, John Wiley & Sons Inc., UK.
- [5] Kiam Heong Ang, Gregory Chong, and Yun Li, "PID Control System Analysis, Design, and Technology" *IEEE Transactions Control System Technology*, Vol.13, No.4, July 2005, pp.559-576.



Mr. Parkpoom Chokchairungroj received the Master's degree in Electrical Engineering from KhonKaen University; KhonKaen, Thailand. With skill excellent electronics microcontroller and Digital signal processing. Current position is a Development Engineering at Defence Technology Institute (Public Organization), Bangkok, Thailand.