

# Optimization of Double Wishbone Suspension System with Variable Camber Angle by Hydraulic Mechanism

Mohammad Iman Makhlespour Esfahani, Masoud Mosayebi,  
 Mohammad Pourshams, Ahmad Keshavarzi

**Abstract**—Simulation accuracy by recent dynamic vehicle simulation multidimensional expression significantly has progressed and acceptable results not only for passive vehicles but also for active vehicles normally equipped with advanced electronic components is also provided. Recently, one of the subjects that has it been considered, is increasing the safety car in design. Therefore, many efforts have been done to increase vehicle stability especially in the turn. One of the most important efforts is adjusting the camber angle in the car suspension system. Optimum control camber angle in addition to the vehicle stability is effective in the wheel adhesion on road, reducing rubber abrasion and acceleration and braking. Since the increase or decrease in the camber angle impacts on the stability of vehicles, in this paper, a car suspension system mechanism is introduced that could be adjust camber angle and the mechanism is application and also inexpensive. In order to reach this purpose, in this paper, a passive double wishbone suspension system with variable camber angle is introduced and then variable camber mechanism designed and analyzed for study the designed system performance, this mechanism is modeled in Visual Nastran software and kinematic analysis is revealed.

**Keywords**—Suspension molding, double wishbone, variable camber, hydraulic mechanism

## I. INTRODUCTION

**T**HE camber angle is inflection side of wheel into vertical line (Fig.1). Camber is caused to attrition rubber wheel, so the camber angle should be adjusted such that it reaches zero. This angle depends on the suspension system. This angle depends on the suspension system. This angle is caused to share the level of flat car tire pressure, that need to be uniform to reduce and inflection rubber.

The advantage of camber is driving stability, because the level reliance increases and brings the center of gravity lower. In this case, the radial tires can be used for side pressure into tire to be tolerated.

F. A. Author is with Malek-e- ashtar University of Technology, Iran, Esfahan (e-mail: iman.mokhles@ gmail.com).

S. B. Author is with Malek-e- ashtar University of Technology, Iran, Esfahan (e-mail: mosayebimass006@yahoo.com).

T. C. Author is with Malek-e- ashtar University of Technology, Iran, Esfahan (e-mail:m.pourshams@yahoo.com).

F. D. Author is with Malek-e- ashtar University of Technology, Iran, Esfahan (e-mail: ahmadkeshavarzi@ yahoo.com).

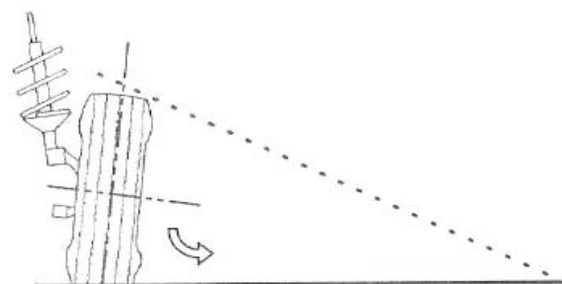

Fig. 1 Camber angle

Negative response of the vehicle is affected by camber angle in three following cases:

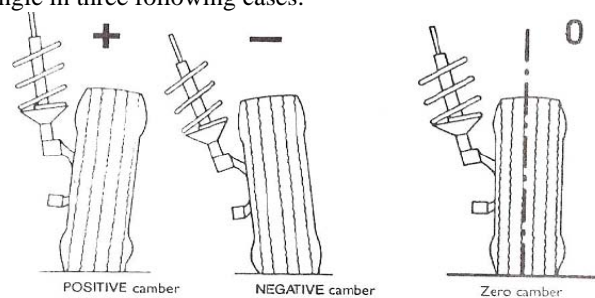

Fig. 2 Size of the camber angle

- In zero camber case, the wheel is perpendicular to the road surface and its steering is relatively difficult. This case is used in tracks.
- Negative camber case for separate suspension systems to increase the level of reliance vehicle on the road, is used in back wheels, but not in front wheels.
- Positive camber for front wheels between 0 to 2 degrees is selected because:

\* In the positive camber, the lateral force is cause to direct wheel upward and thus the force on the trunnion nut removed and the two cone bearing will be established well(Fig.3).

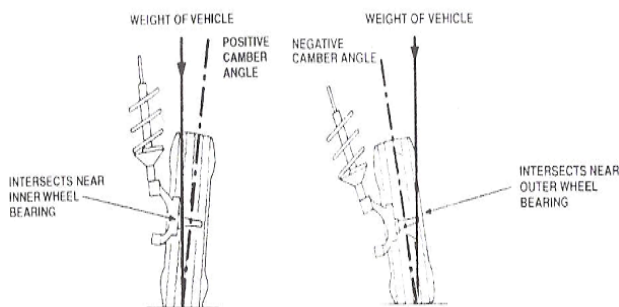

Fig. 3 The effects of positive and negative camber angle

\* When the wheel is lie under the loads, it could be lie in vertical state. Whenever camber angle is not positive, bending moment take the front wheels to the negative camber case. Positive camber angle causes that front wheels lie under full load and then the wheels lie in vertical state.

The cornering force that a tire can develop is highly dependent on its angle relative to the road surface, and so camber angle has a major effect on the road holding of a car. To optimizing camber angle in a turn, suspension mechanism must be rotate to allow wheel to deflect, therefore the relatively large wheel travel and roll stiffness need to be soft, therefore difficult design challenges are that large travel and soft roll stiffness that reduce holding force and handling on the road. We introduce a simple and economical suspension mechanism based on the double wishbone system with variable camber angle for solving the challenges [1].

Different mechanisms by different researchers and inventors around the world for variable camber angle to the suspension system has been introduced ([2]-[14]), for example, W.Schiehlen and T.Schirle ([15]) have introduced a mechanism that it's designing and manufacturing are expensive and the camber angles change the toe angles too.

## II. ADJUSTMENT OF CAMBER ANGLE

Please In the vehicles that have high speed, the risk of reversal increases when the vehicle is turned, with the appropriate scheme lever that plan to stimulus wheels, negative camber angle occurs in the rear wheels. This operation causes increased reliance on surface, low gravity and low upset property.

Negative camber angle is only -1 degree and difference between the two wheels is not more than -20 degrees, otherwise the wheels of one side may be slide.

Eccentricity mode in vehicle is occurred when the vehicle is turning (Fig.3), so centrifugal force makes a variety of situations in wheel that gives the following:

\* In the inside turn wheels due to opening suspension springs, is occurred negative camber.

\* In the outside turn wheels due to gather the suspension springs, is occurred positive camber.

As shown in Fig.3 in a turn the camber angle of inside turn wheel with initial negative camber value would be more negative and positive camber of turn influence that of outside turn wheel with initial negative value and tend to twist the

wheel to vertical state. So, effective level reliance increases [1].

## III. EFFECT OF SUSPENSION ON CAMBER

### A. Double Wishbone Front Suspension

In such suspension, camber is positive and about 1 degree. So in the turn, camber of that wheel is inside turn is zero or negative (useful) and outside turn is negative (useful).

### B. Mac Pherson Front Suspension

In This case, normally, positive camber angle is very low and when the vehicle turn, camber angle of that wheel is inside turn is negative and outside turn is positive[1].

## IV. DESIGNED MECHANISM INTRODUCTION

Use and performable on most cars with double wishbone suspension system and has simple control system while other angles of tires are not changed. The camber angle could be change in five following cases:

### A. Dimensional changing in upper arm

### B. Dimensional changing in lower arm

### C. Changing in the place of lower connection

### D. Changing in the place of upper connection

### E. Changing in the stiffness of spring

Now, we review the above cases.

### A. Dimensional changing in upper arm

- Disadvantages:

Because, upper arm suffer many loads, replacing the piece which can have variable length and bear applied forces to the arm is very difficult and process of manufacturing is costly too, meanwhile because of the length of arm is variable, the mechanism control will be difficult.

- Advantages:

One of the best advantages of this way is that the suspension geometry variables change minimally and applied forces to upper arm less than that of to lower arm.

### B. Dimensional changing in lower arm

- Disadvantages:

Because lower arm similar to upper arm suffer many loads, replacing the piece which can have variable length and bear applied forces to the arm is very difficult and process of manufacturing is costly too, meanwhile because of the length of arm is variable, the mechanism control will be difficult, also the spring restricts our space.

- Advantages:

Only advantage that is not significant is changing effective width and changing center of mass location into the base too.

### C. Changing in the place of lower connection

- Disadvantages:

This case causes non-tangible change in suspension geometry, which of course can be ignored, but as mentioned above, due to the severe forces that apply to the lower arm, the numerous forces apply to the joints.

- Advantages:

This case due to the above A and B cases is more feasible, low cost and with more safety.

*D. Changing in the place of upper connecting*

- Disadvantages:

This way causes non-tangible change in suspension geometry, which of course can be ignored.

- Advantages:

Since applied forces to the upper arm are less than that of lower arm, changing in the place of upper connection is very reasonable and more possible, lower cost and more safety than A and B and C cases.

*E. Changing in the stiffness of spring*

- Disadvantages:

Changing in the camber angle freely is impossible.

- Advantages:

The suspension geometry variables could not be change.

As aforementioned above, low cost, possible way and also reliable way is changing in the connection of upper arm location.

The mechanism is designed to changing the camber angle such that the upper arm rotates by crankshaft which is jointed to chassis.

The crankshaft rotates by two hydraulic cylinders which control by a control system.

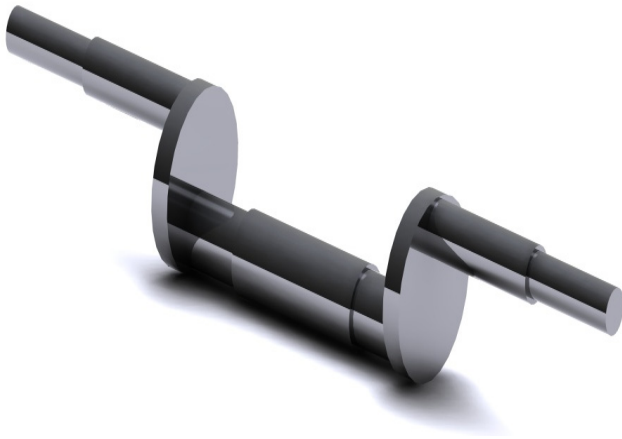

Fig. 4 Crankshaft design



Fig. 5 View of the upper mechanism



Fig. 6 Mode of the mechanism operation

We used a hydraulic system to rotate the crankshaft of mechanism.

Reasons for the use of hydraulic system are [16]:

- High speed
- Lower cost
- Less space
- High confidence
- Simple design
- Increased power capability
- Easily and accuracy control
- Flexibility
- High efficiency



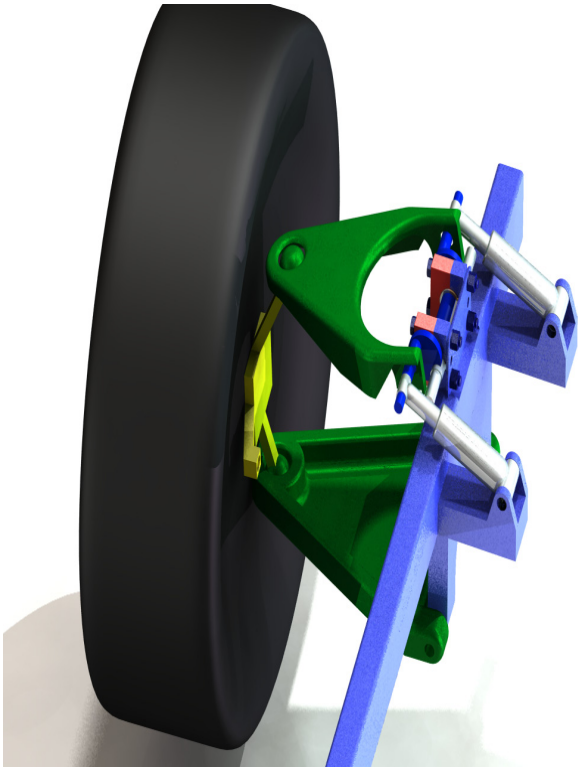

Fig. 7a View of the assembly mechanism



Fig. 7b Zoom in view of the assembly mechanism

### V. CAMBER VARIATION OF DOUBLE A-ARM SUSPENSION [17]

When a wheel moves up and down with respect to the vehicle body, depending on the suspension mechanism, the wheel may camber. The mechanism is equivalent to a four-bar linkage with the ground link as the vehicle chassis. The wheel is always attached to a coupler point C of the mechanism. We set a local suspension coordinate frame (x, y) with the x-axis

indicating the ground link MN. The x-axis makes a constant angle  $\theta_0$  with the vertical direction. The suspension mechanism has a length a for the upper A-arm, b for the coupler link, c for the lower A-arm, and d for the ground link. The configuration of the suspension is determined by the angles  $\theta_2, \theta_3$  and  $\theta_4$ , all measured from the positive direction of the x-axis (Fig. 8).

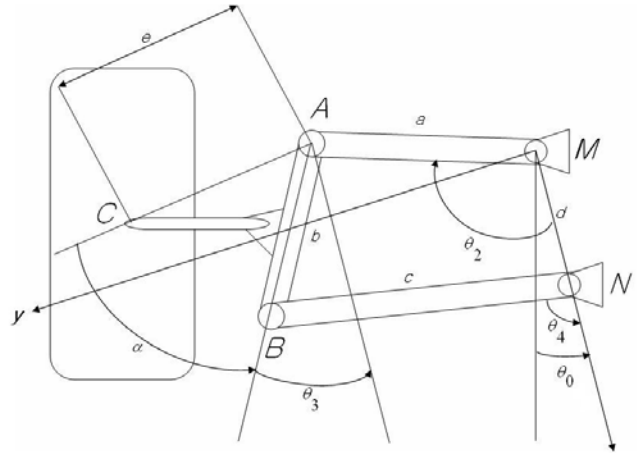

Fig. 8 View of the variable mechanism

When the suspension is at its equilibrium position, the links of the double A-arm suspension make initial angles  $\theta_{20}, \theta_{30}$  and  $\theta_{40}$  with the x-axis.

The equilibrium position of a suspension is called the rest position.

To determine the camber angle during the fluctuation of the wheel, we should determine the variation of the coupler angle  $\theta_3$ , as a function of vertical motion z of the coupler point C.

Using  $\theta_2$  as a parameter, we can find the coordinates

$(x_c, y_c)$  of the coupler point C in the suspension coordinate frame (x, y) as

$$\begin{aligned} x_c &= a \cos \theta_2 + e \cos(p + q - \alpha) \\ y_c &= a \sin \theta_2 + e \sin(p + q - \alpha) \end{aligned} \quad (1)$$

Where,

$$\begin{aligned} q &= \tan^{-1}\left(\frac{a \sin \theta_2}{d - a \cos \theta_2}\right) \\ p &= \tan^{-1}\left(\frac{\sqrt{4b^2 f^2 - (b^2 + f^2 - c^2)}}{b^2 + f^2 - c^2}\right) \end{aligned} \quad (2)$$

$$f = \sqrt{a^2 + d^2 - 2ad \cos \theta_2}$$

The position vector of the coupler point is:

$$u_c = x_c \hat{i} + y_c \hat{j} \quad (3)$$

And the unit vector in the z-direction is:

$$u_z = -\cos \theta_0 \hat{i} - \sin \theta_0 \hat{j} \quad (4)$$

Therefore, the displacement  $z$  in terms of  $x$  and  $y_c$  is:

$$z = u_c u_z = -x_c \cos \theta_0 - y_c \sin \theta_0 \quad (5)$$

The initial coordinates of the coupler point C and the initial value of  $z$  are:

$$\begin{aligned} x_{c0} &= a \cos \theta_{20} + e \cos(p_0 + q_0 - \alpha) \\ y_{c0} &= a \sin \theta_{20} + e \sin(p_0 + q_0 - \alpha) \end{aligned} \quad (6)$$

$$z_0 = -x_{c0} \cos \theta_0 - y_{c0} \sin \theta_0$$

And hence, the vertical displacement of the wheel center can be calculated by

$$h = z - z_0 \quad (7)$$

The initial angle of the coupler link with the vertical direction is  $\theta_0 - \theta_{30}$ .

Therefore, the camber angle of the wheel would be:

$$\gamma = \theta_{30} - \theta_3 \quad (8)$$

The angle of the coupler link with the x-direction is equal to

$$\theta_3 = 2 \tan^{-1} \left( \frac{-E \pm \sqrt{E^2 - 4DE}}{2D} \right) \quad (9)$$

Where,

$$D = J_5 - J_1 + (1 - J_4) \cos \theta_2$$

$$E = -2 \sin \theta_2$$

$$F = J_5 + J_1 - (1 - J_4) \cos \theta_2$$

And:

$$J_1 = \frac{d}{a}$$

$$J_2 = \frac{d}{c}$$

$$J_3 = \frac{a^2 - b^2 + c^2 + d^2}{2ac} \quad (11)$$

$$J_4 = \frac{d}{b}$$

$$J_5 = \frac{c^2 - a^2 - b^2 - d^2}{2ab}$$

## VI. HYDRAULIC SYSTEM DESIGN

### A. Major components of hydraulic systems [18]

Submission of Hydraulic system for this mechanism consists of two cylinders and pistons, two valves 3 / 5, compressor and two speed control valves.

The diagram of the hydraulic system is shown in Fig 9.

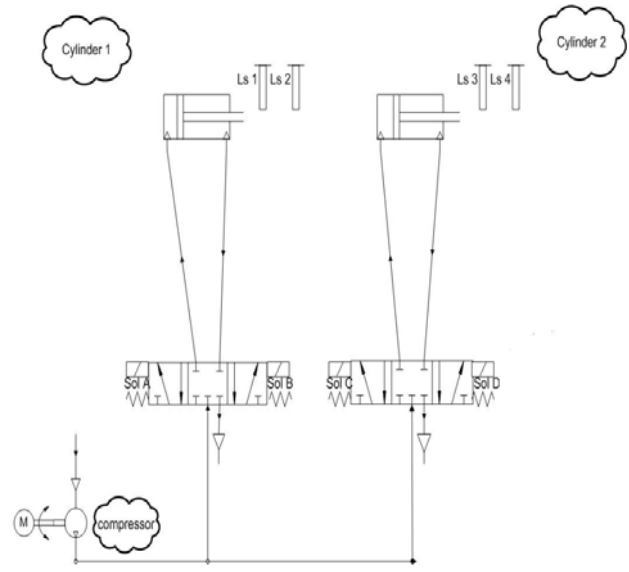

Fig. 9 View of the hydraulic system diagram

First, we explain by the ladder diagram that how the system operates (Fig.10).

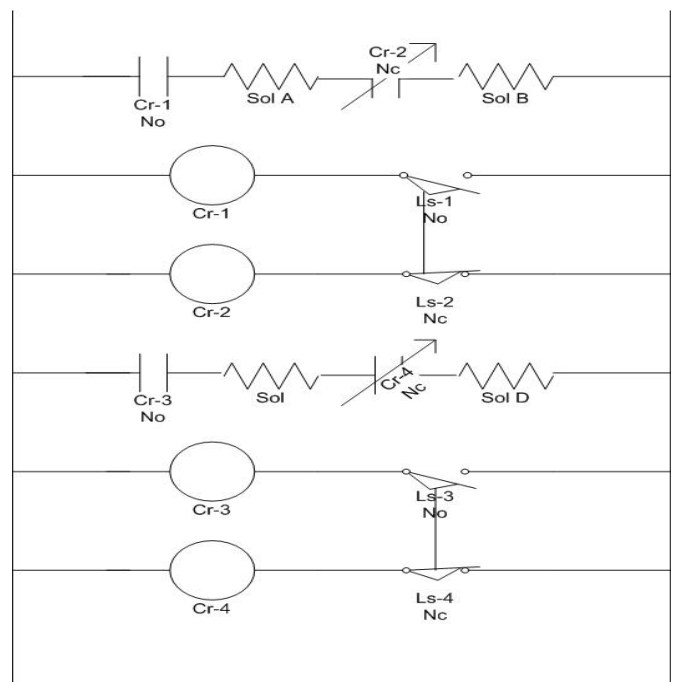

Fig. 10 Ladder diagram of the hydraulic system

Two cylinders A and B move in parallel with each other. When sol A and C are stimulated, cylinders A and B both are put forward motion. Forward motion is starting by the Ls-1 key. Then, if the key Ls-2 is activated, the key Ls-1 is inactive and conductor Cr-2 is activated, so conductor Cr-1 is inactivated and sol A and B is inactivated too. In this case, valve 3 / 5 puts in normal condition. In this situation steady state system will be established and cylinders and pistons will be fixed.

When the key Ls-3 is activated, conductor Cr-3 is activated

too. So, sol B and D are activated and move back of pistons A and B will begin.

• Note:

Pistons rate of return are determined by the control system, and the motion stopped when the power desired is provided.

B. Analysis of hydraulic system

In the system performance conditions, as computed before load on each rod of the piston must be assumed 100 (kg). So, the diameter of the piston rod is obtained from Euler theory buckling. Indeed it implies to critical axial forces of the rod.

From Euler theory, we have [17]:

$$k = \frac{\pi^2 EI}{L_e^2} \quad (12)$$

Where:

K: Axial critical force (N)

EI: Bending rigidity ( $N.m^2$ )

Le: Effective length (m)

Following parameters for a cylinder is considered:

$P_F$  : Pressure (pa)

$P_A$  : Pressure in side of the piston rod (pa)

$L$  : Length of cylinder stroke (m)

$A_F$  : Effective cross section area of cylinder in the full area ( $m^2$ )

$A_A$  : Effective cross section area of cylinder piston rod

$V_E$  : Speed of the cylinder forward stroke (m/s)

$V_F$  : Speed of the cylinder back stroke (m/s)

$T_E$  : The time of forward stroke (sec)

$T_R$  : The time of Back stroke (sec)

$Q_F$  : Flow rate in side of the full area of the cylinder ( $\frac{m^3}{sec}$ )

$Q_A$  : Flow rate in side of the full area of the rod piston

VII. RESULTS OF CALCULATION

A. The dimensions of the equivalent kinematic model are:

$$\begin{aligned} a &= 198(mm) & e &= 198(mm) \\ b &= 269(mm) & \alpha &= 33(deg) \\ c &= 315(mm) & \theta_{20} &= 99.625(deg) \\ d &= 188(mm) & \theta_{30} &= 28(deg) \\ \theta_0 &= 9.625(deg) & \theta_{40} &= 93(deg) \end{aligned} \quad (13)$$

We may calculate h and  $\gamma$  by varying the parameter

$\theta_2$ . Fig.11 illustrates h as a function of the camber angle  $\gamma$ .

For this suspension mechanism, the wheel gains a positive camber when the wheel moves up, and gains a negative

camber when it moves down.

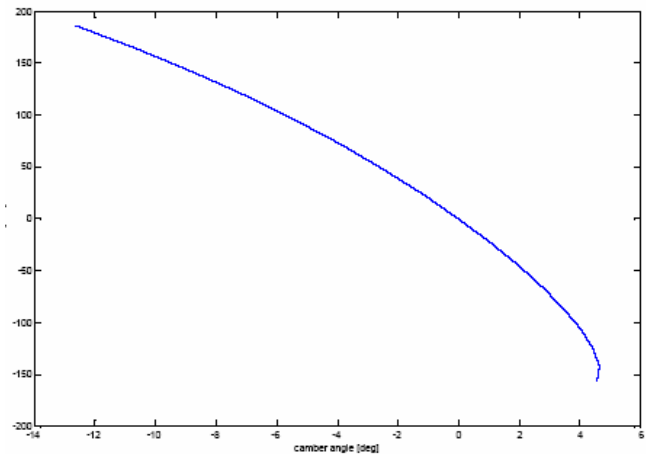

Fig. 11 Chart of the vertical displacement of the wheel center respect to the camber angle

B. CALCULATION OF HYDRAULIC SYSTEM

We selected standard effective length for our case study. So we have:

$$k = F.S = 100(kg) \times 3.5 = 350(kg) \quad (14)$$

So, minimum diameter must be 3.9. As the standards and limitation of hydraulic, pressure required for a particular speed, the following have been selected:

$$D = 50(mm) \text{ cylinder and } d = 20(mm) \text{ Bore} \quad (15)$$

$$A_F = \frac{\pi D^2}{4} = 19.63(cm^2) \quad (16)$$

$$A_A = \frac{\pi}{4}(D^2 - d^2) = 16.5(cm^2)$$

Assume that the total time for the forward and back movement is 2s. (But this time is considered for the length of stroke 8cm, so the time required for the operation of this system is less, because the length of stroke in operation less than 8 cm. So operation time is less, which is better).

$$T = T_R + T_E = 2(sec)$$

$$Q_P = Q_F = Q_A \rightarrow A_F \times V_E = A_A \times V_R$$

$$V = \frac{L}{T} \Rightarrow T_E = 1.09(sec), T_R = 0.91(sec) \quad (17)$$

$$\Rightarrow V_R = 0.044(\frac{m}{s}), V_E = 0.037(\frac{m}{s})$$

$$Q_F = 4.36(\frac{lit}{min}), Q_A = 4.36(\frac{lit}{min})$$

$$\begin{aligned} F_E = F_R = P \times A \Rightarrow \\ P_A = 6.06(bar), P_F = 5.1(bar) \end{aligned} \quad (18)$$

Considering the above flow rate, we required to a compressor with flow rate about  $5(\frac{lit}{min})$ . If flow rate is min n selected higher, piston speed is higher too.

As a result, pressure compressor with safety factor is considered 7 (bar).

### VIII. KINEMATICS ANALYSIS OF MECHANISM

This mechanism simulation and analysis is given in Visual Nastran software. How to change angular velocity rotation of the wheel is given in below chart Fig.12.

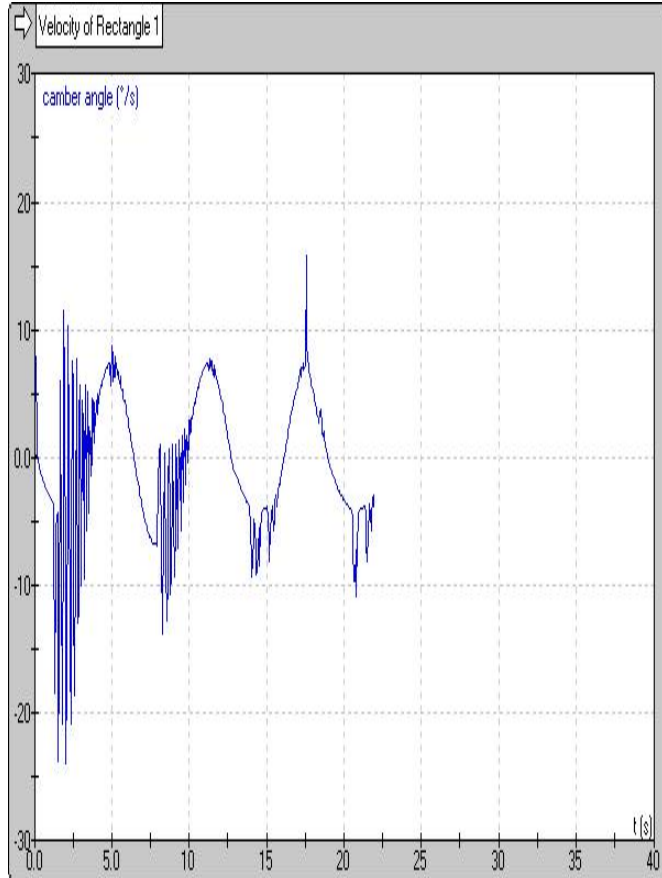

Fig. 12 Angular velocity of camber angle

As is shown in Fig.12 the wheel rotates with the variable angular velocity, so this problem must be considered by the control system design.

How to changing the camber angle, rotation of the crankshaft and piston rod displacement is shown in below Fig.13-15.

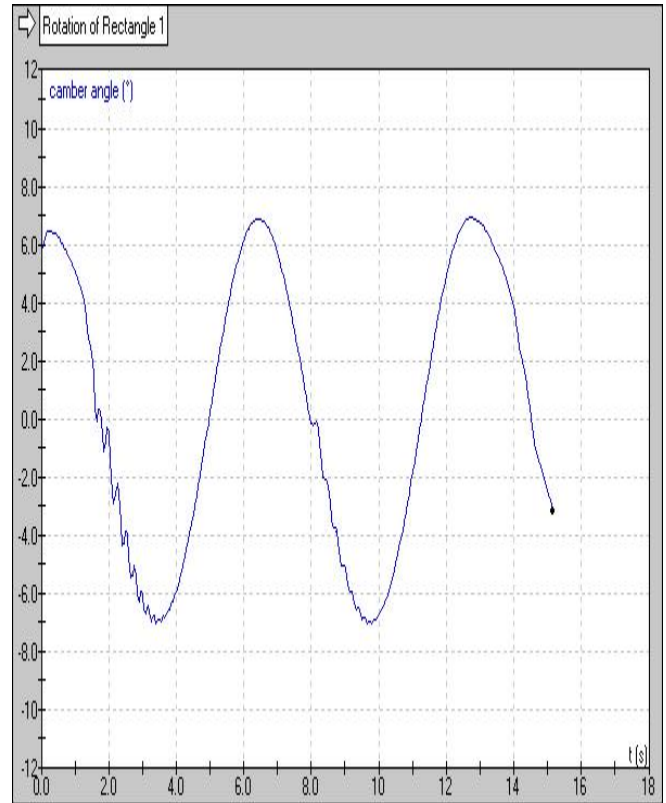

Fig. 13 The changing of camber angle

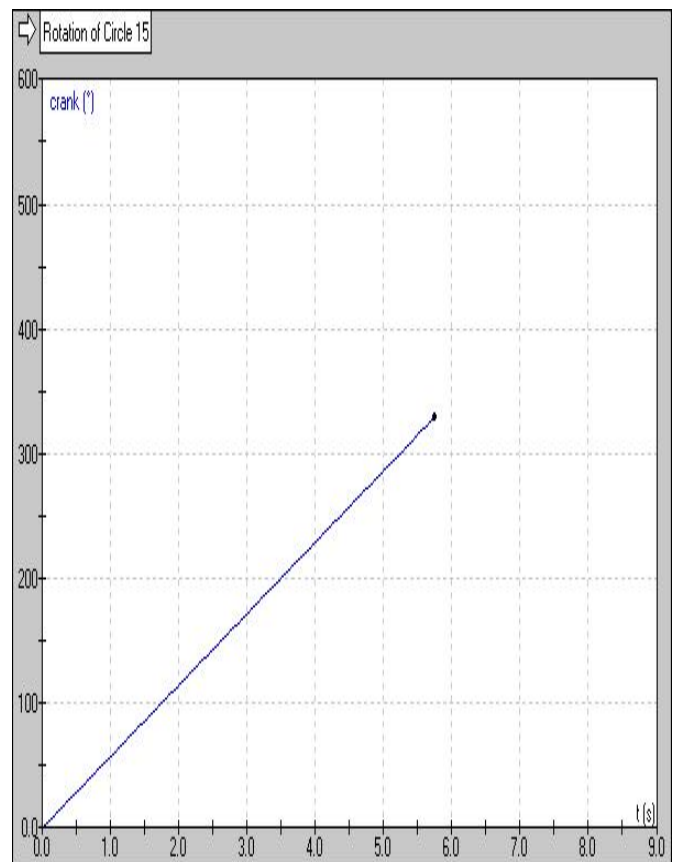

Fig. 14 The rotation of the crankshaft

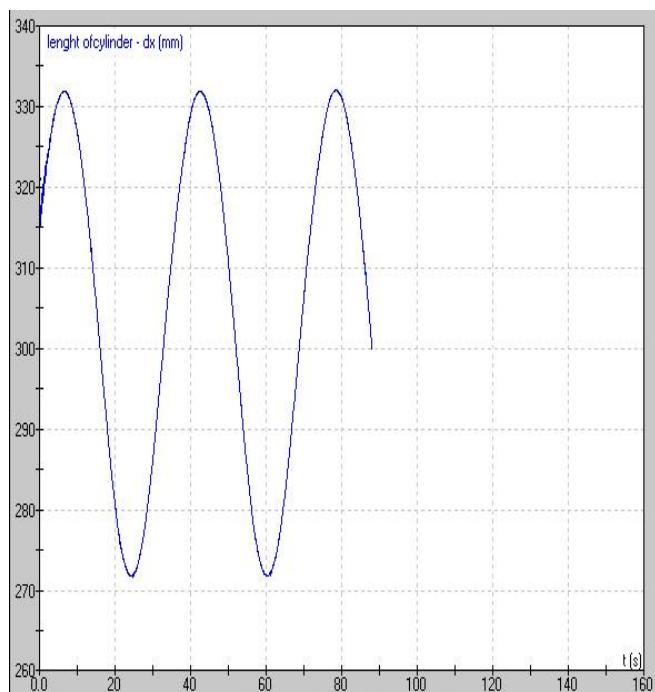

Fig. 15 Piston rod displacement

## IX. CONCLUSION

This mechanism can change camber angle from -5.5 degree to 5.5 degree, piston rod movement about 60 mm and crankshaft about 650 degree. As is shown in Fig.12, this mechanism has very short response time that can be a major advantage for the vehicle stability. So a car suspension system mechanism is introduced that could be adjust camber angle and the mechanism is application and also inexpensive.

## REFERENCES

- [1] R.Kazemi, Principles design of vehicle suspension and steering systems, Second Edition, in Persian.
- [2] J. Goldberg, Adjusting automobile suspension system, United States patent, US4191274, Mar.4, 1980.
- [3] J. Goldberg, Adjusting automobile suspension system, United States patent, US4371191, Feb.1, 1983.
- [4] K.M.Choudhery, Variable camber suspension system, United States patent, US6874793, Apr.5, 2005.
- [5] L.Serra, C.Tetaz, Vehicle suspension with camber control, United States patent, US6688620, Feb.10, 2004.
- [6] D.Laurent, M.Sebe, Vehicle suspension having active camber variation, United States patent, US6547620, Apr.15, 2003.
- [7] D.Laurent, M.Sebe, Vehicle suspension having active camber variation, United States patent, US6406036, Jun.18, 2002.
- [8] K.M.Choudhery, Variable camber suspension system, United States patent, US6279920, Aug.28, 2001.
- [9] W.Weiss, Vehicle suspension with automatic camber adjustment, United States patent, US6267387, Jul.31, 2001.
- [10] Dewitt Gabel, Zero camber steering suspension, United States patent, US5009447, Apr.23, 1991.
- [11] H.A.Rori, W.A.Hoenle, Independent suspension toe and camber adjustment system, United States patent, US4973075, Nov.27, 1990.
- [12] F.Andre, M.Blondelet, Vehicle with a variable camber suspension device, United States patent, US20090033057, Feb.5, 2009.
- [13] R.Boston, Vehicle suspension system with a variable system, United States patent, US20090194965, Aug.6, 2009.

- [14] M.Sebe, Vehicle having suspension system with variable camber and vertical suspension in the plane of the wheel, United States patent, US6511078, Jan.28, 2003.
- [15] W. Schiehlen and T. Schirle, Modeling and simulation of hydraulic components for passenger cars, Vehicle System Dynamics journal, Vol. 44, Supplement, 2006, 581-589.
- [16] H.Dalayeli, Industrial hydraulic, Volume 1, Sixth Edition, 2006, in Persian.
- [17] R.N.Jazar, Vehicle dynamics theory and application, Springer, 2008.
- [18] H.Dalayeli, Industrial hydraulic, Volume 2, Third Edition, 2006, in Persian.