

# Characteristics of Cascade and C3MR Cycle on Natural Gas Liquefaction Process

Jung-in Yoon, Ho-saeng Lee, Seung-taek Oh, Sang-gyu Lee and Keun-hyung Choi

**Abstract**—In this paper, several different types of natural gas liquefaction cycle. First, two processes are a cascade process with two staged compression were designed and simulated. These include Inter-cooler which is consisted to Propane, Ethylene and Methane cycle, and also, liquid-gas heat exchanger is applied to between of methane and ethylene cycles (process2) and between of ethylene and propane (process3). Also, these cycles are compared with two staged cascade process using only a Inter-cooler (process1). The COP of process2 and process3 showed about 13.99% and 6.95% higher than process1, respectively. Also, the yield efficiency of LNG improved comparing with process1 by 13.99% lower specific power. Additionally, C3MR process are simulated and compared with Process 2.

**Keywords**—Cascade. C3MR. LNG. Inter-cooler.

## I. INTRODUCTION

NATURAL gas is the mixture with methane, ethane, propane, butane, etc., and methane accounts for about 80% of these components, and normal boiling point is about  $-162^{\circ}\text{C}$ . [1] Natural gas is being preferred as the green energy which is colorlessness, odorless and non-toxicity. Furthermore consumption rate of natural gas is increasing according to increment of international oil prices. [2] Natural gas transportation systems are divided into PNG (Pipeline Natural Gas) system and LNG (Liquefied Natural Gas) system. LNG system has an advantage which is easier to transfer with handling smaller volume about 1/600 than PNG system. Therefore, natural gas liquefaction industry has been in the spotlight recently as a higher value-added industry. [3] However, some developed companies monopolize liquefaction plant market.

The researches and developments are started in 1960s. D. L. Andress of Phillips company described about development of Optimized cascade process, [4] Kikkawa et al. simulated mixed refrigerant liquefaction process using pre-cooling loop and expander with CHEM CAD software, [5] Terry et al. analyzed

and compared representative liquefaction process with Hysys software, [6] Wen-Sheng Cao et al. simulated liquefaction process using refrigerant which mixed nitrogen and methane with Hysys software, and then compared performances with mixed refrigerant liquefaction process. [7] In the Korea, Yoon et al. simulated cascade process with Hysys software, and then offered basic data to this research. [8]-[12]

In this study, we will offer basic data those are analyzed Characteristics of Performance of Cascade and C3MR processes through simulation with Hysys software to secure to secure a competitiveness in the industry of natural gas liquefaction plant.

## II. LIQUEFACTION PROCESS

### A. Basic Cascade Process

This process consists of three pure refrigerants which have different boiling temperature, such as methane, ethylene and propane. First of all, natural gas is cooled to  $-35^{\circ}\text{C}$  in the propane cycle, then it is cooled to  $-90^{\circ}\text{C}$  in the ethylene cycle, finally it is liquefied to  $-155^{\circ}\text{C}$  in the methane cycle.

### B. Cascade Process with Two Staged Inter-cooler

This process is that two staged compression with intercooler type is applied on the basic cascade process (process1). Liquefied refrigerant from condenser is bypassed and evaporate in the intercooler after expanded. Therefore main refrigerant to evaporator is sub-cooled.

### C. Cascade Process with Two Staged Inter-cooler

These processes are those liquid-gas heat exchangers are applied to between of two cycles. One of these processes is that sub-cooled liquid refrigerant which is bypassed from inter-cooler in the ethylene cycle and hot gaseous refrigerant from outlet of high pressure compressor in the methane cycle are exchanged the heat in the liquid-gas heat exchanger to liquefy the hot gaseous methane (process2). The other process is that one more liquid-gas heat exchanger is applied to between of propane and ethylene cycle (process3) on the process2. Fig. 1 shows about process 2.

### D. C3MR(Propane Mixed Refrigerant) Process

This process are formed two cycles such as MR (Mixed Refrigerant) cycle and C3 (Propane) cycle. Natural gas is pre-cooled to about  $-35^{\circ}\text{C}$  through C3 cooler, than liquefied at  $-160^{\circ}\text{C}$  in the MR heat exchanger. This process is shown in the Fig.2

Jung-in Yoon is with Pukyong National University, Busan, 608-739, Korea, (corresponding author to provide phone: 82-051-629-6180; fax: 82-051-629-6180; e-mail: Yoonji@pknu.ac.kr).

Ho-saeng Lee, with Pukyong National University, Busan, 608-739, Korea, (e-mail: purger77@pknu.ac.kr).

Seung-taek Oh is with Pukyong National University, Busan, 608-739, Korea, (e-mail: tmdxorl@pknu.ac.kr).

Sang-gyu Lee is with Korea Gas Corporation, Incheon, 406-130, Korea, (e-mail: lsg@kogas.or.kr)

Keun-hyung Choi is with Korea Gas Corporation, Incheon, 406-130, Korea, (e-mail: kevin@kogas.or.kr)

### III. SIMULATION CONDITION

#### A. Condition of simulation

In this simulation, a feed gas composition is assumed with treated natural gas which is removed acid gas, water, mercury and heavy hydrocarbons from Nigeria LNG plant. Table 1 shows feed gas and MR composition. Assumed conditions of simulation are shown in Table 2. Feed gas mass flow is set based on trane capacity 5MTPA (Million Ton Per Annum, a bypass flow rate of cascade process is set 15% of mass flow of each cycle, a middle pressure is set 50% of high pressure and outlet pressure of expansion valve of the intercooler inlet side is assumed same as middle pressure.

TABLE I  
COMPOSITION OF NATURAL GAS & MR

Component	Mole fraction of Cascade[%]	Mole fraction of MR[%]
Nitrogen	0.007	0.02
Methane	0.82	0.44
Ethane	0.112	0.39
Propane	0.04	0.15
iso-Butane	0.012	-
n-Butane	0.009	-
Total	1	1

#### B. Equations

TABLE II  
ASSUMED CONDITIONS

Parameter	Cascade	C3MR
Refrigerant	Methane, Ethylene, Propane	MR
Bypass flow rate	50	-
Middle pressure	50	-
Feed gas mass flow rate	158.5	
Feed gas temperature	32	
Feed gas pressure	5000	
2 <sup>nd</sup> fluid temperature	40	

Two kinds of main equations are used for the liquefaction simulation.[13] The Peng- Robinson equation of state applies functionality to some specific component-component interaction parameters, which can be used in the calculation of phase equilibrium.

It is written by

$$P = \frac{RT}{V-b} - \frac{a}{V(V+b)+b(V-b)} \quad (1)$$

$$a = \sum_{i=1}^N \sum_{j=1}^N a_i a_j (a_i a_j)^{ab} \cdot (1 - k_{ij})$$

$$b = \sum_{i=1}^N a_i b_i$$

Where P [Pa] is a pressure, R [N·m/kg·K] is a gas constant, T [K] is a temperature, V [m<sup>3</sup>/kg] is a specific volume, a and b are the constants relating to the gas species, x is mole fraction of a certain component, k is binary interaction coefficient.

It is rewritten as

$$P = Z^3 - (1-B)Z^2 + (A-2B-3B^2)Z - (AB-B^2-B^3) = 0 \quad (2)$$

$$A = \frac{aP}{(RT)^2} \quad B = \frac{bP}{RT}$$

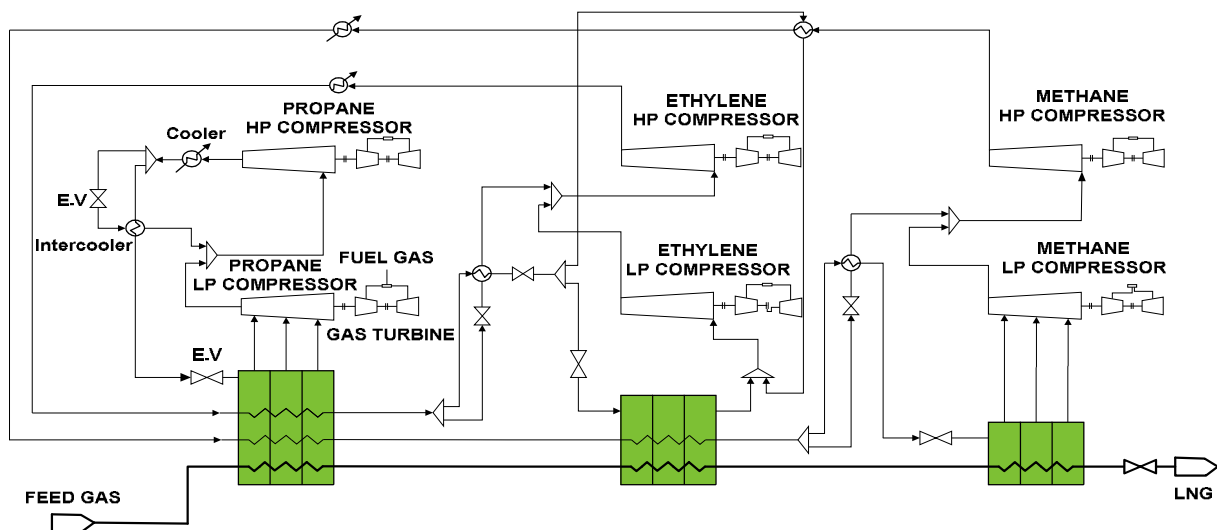

Fig.1 Schematic diagram of cascade process using liquid-gas heat exchanger

Where Z is a constraining factor, A and B are the coefficients relating to the gas state parameters.

The Lee-Kesler-Plöcker equation is an accurate general method for non-polar substances and mixtures, which can be used in the calculation of enthalpy and entropy of mixed components.

It is given by

$$P = Z^{(0)} + \frac{\omega}{\omega^{(r)}} (Z^{(r)} - Z^{(0)}) \quad (3)$$

where  $\omega$  is an acentric factor,  $o$  and  $r$  denote the relevant parameters of simple and reference liquids.

#### IV. RESULTS AND CONSIDERATIONS

##### A. Cascade process

Fig. 4 shows comparison of variation of each refrigerant mass flow rate. Only mass flow rate of propane of Process 2 decreased about 2.4%, but that of ethylene and methane increased about 8.2% and 4.4% than those of process1. Mass flow rate of all refrigerants of Process 3 are increased about 2.3 ~ 9.4%. According to supplement of liquid-gas heat exchanger, bypass mass flow rate increased and mass flow rate of refrigerant to each cycle's evaporator also decreased then that of whole cycles increased. The other hand, temperature of inlet of compressor is drop owing to increment of sub-cooling and then the compression work is decreased. Therefore, we can conclude that COP is improved.

Performances of each process in a same conditions such as liquefaction rate and temperature are shown in Fig. 5. Refrigeration capacity of process 2 is 0.9% higher and that of process 3 is lower than that of process 1. Since a state of high temperature of methane is cooled with bypassed ethylene

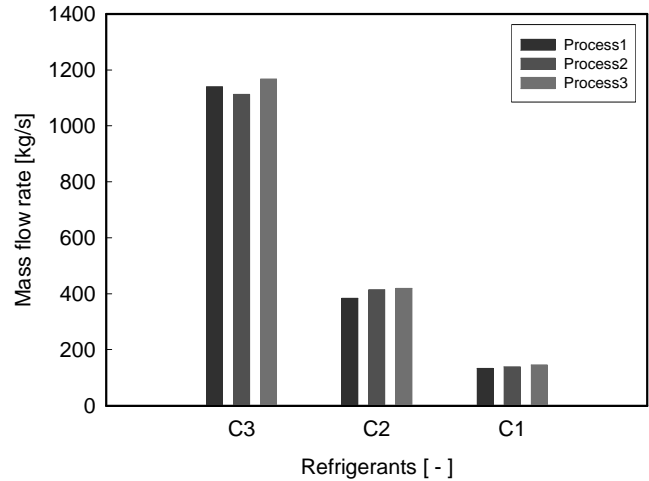

Fig. 4 Comparison of refrigerant mass flow rate

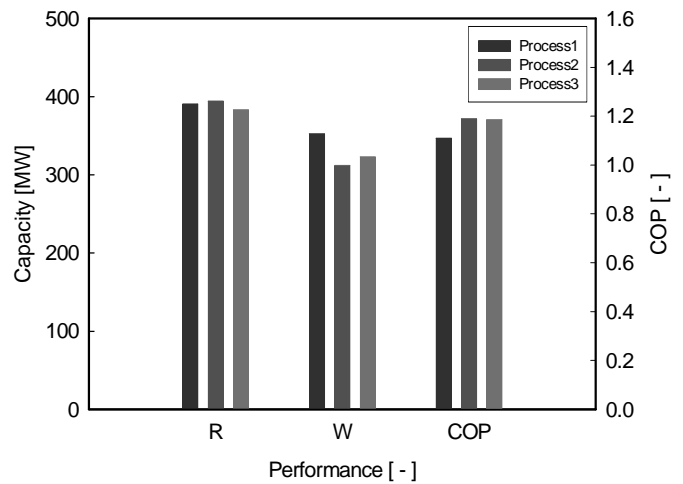

Fig. 5 Comparison of performance

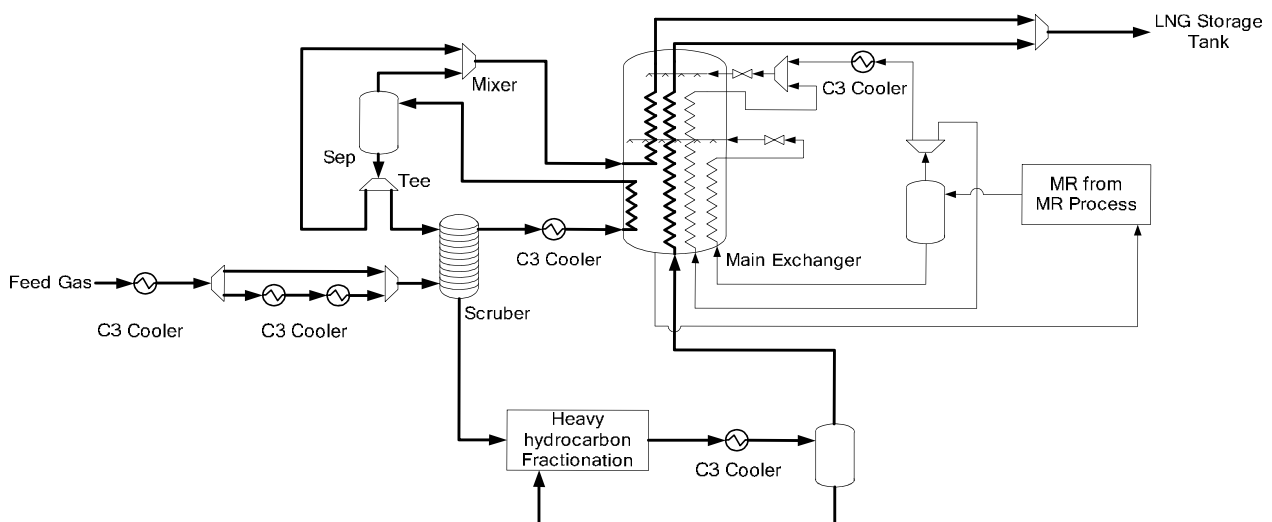

Fig.2 Schematic diagram of C3MR

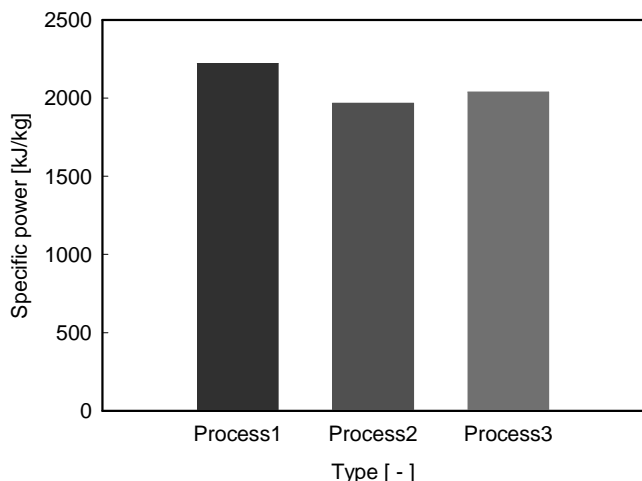

Fig. 6 Comparison of specific power

condensing temperature is decreased as a result, refrigeration capacity of process 2 increased. Refrigeration capacity of Process 3 decreased, even though condensing temperature is lower. This is because, mass flow rate of propane to inlet of propane evaporator which has dominant influence on refrigerant capacity is decreased as bypassed.

Compressor work of process 2 and that of process 3 are 11.44% and 8.26% lower than that of process 1. In this figure, process 3 shows higher compressor work than that of Process 2. This is because, requirement of refrigerant is increased with decrement of mass flow rate of propane to inlet of propane evaporator as liquid-gas heat exchanger is added. COP means efficiency of system and that is calculated by refrigeration capacity per compressor work. COP of process 2 shows the highest increment ratio about 13.9%.

Fig. 6 and Fig. 7 show power consumption per productivity of LNG and productivity of LNG per power requirement. Power consumption per productivity of LNG of Process 2 is the largest decrement ratio about 11.44% and productivity of LNG per power requirement of Process 2 is the highest increment ratio about 1.68%. As a result, performance and efficiency of process 2 is expected that is the best in these processes.

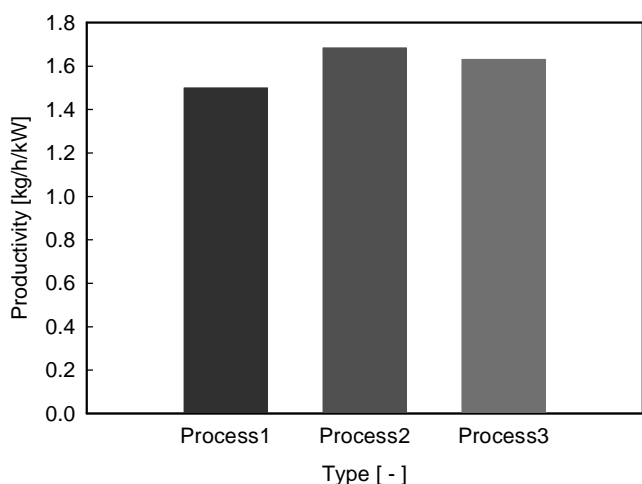

Fig. 7 Comparison of productivity

### B. C3MR process

This process has the highest performance and efficiency in existing liquefaction plants and it has a position up to 70% in liquefaction plant market in the world. For these reasons, it is simulated and analyzed. Performances of C3MR is shown in Table 3.

TABLE III  
PERFORMANCES OF C3MR

Process	Compressor Work [MW]	Refrigerant Capacity [MW]	COP [-]	Specific Power [kJ/kg]
C3MR	171.9	366.1	2.13	934.6
Cascade	312.1	394.5	1.26	1,968.5

Its performances show difference caused by containing heat exchange line such as recovery of waste heat from cascade in principal parameter. Later on, research on C3MR process will be proceeded and we will develop more efficient C3MR process.

### V. CONCLUSIONS

In this study, liquefaction processes are simulated and analyzed focused on decrement of power consumption per productivity of LNG and increment of productivity of LNG per power requirement by reducing compressor work which has a great influence on efficiency of liquefaction process. Results are showed as follows.

1. Mass flow rate of only propane of process 2 decreased about 2.4%, but that of the others increased about 2.3 ~ 9.4%.
2. Refrigeration capacity of Process 2 increased, but that of process 2 decreased compared with process 1. Compressor works of Process 2 and process 3 decreased and COP of process 2 shows the highest increment ratio about 13.9%.
3. Power consumption per productivity of LNG of Process 2 is the largest decrement ratio about 11.44% and productivity of LNG per power requirement of Process 2 is the highest increment ratio about 1.68%.

In this research, process 2 is the top ranked with high Efficiency in cascade processes and we will use of these result to research on improvement of performance and efficiency in liquefaction process.

### ACKNOWLEDGMENT

This research was supported by a grant from the Gas Plant R&D Center funded by the Ministry of Land, Transportation and Maritime Affairs (MLTM) of the Korean government.

### REFERENCES

- [1] Sang gyu Lee, Kun hyung Choe, Young myung Yang, The state of art of LNG Liquefaction Plant Technologies, The 3rd Korean Congress of Refrigeration, vol. 3, pp. 65-68, 2009
- [2] H. S. Chang., B. N. Lee, B. S. Gu, A Raise Plan of competitiveness of Internal Company in the overseas Plant market, Construction & Economy Research Institute of Korea, Vol. 19, pp. 2-30, 2007
- [3] Seung Taek Oh, Ho Saeng Lee, Jung In Yoon, Sang Gyu Lee, Development of LNG Liquefaction Process, Journal of the SAREK, Vol. 38, No. 3, pp. 13-17, 2009

- [4] D. L. Andress, "The Phillips Optimized Cascade LNG Process a Quarter Century of Improvement", The Permission of the Institute of Gas Technology, 1996
- [5] Yoshitugi Kikkawa et. al, "Development of Liquefaction Process for Natural Gas", Journal of Chemical Engineering of Japan, Vol. 30, No. 4, pp. 625-630, 1997
- [6] L. Terry, "Comparison of Liquefaction Process", LNG Journal 21, No. 3, pp. 28-33, 1998
- [7] Wen-sheng Cao et. al, "Parameter Comparison of Two Small-scale Natural Gas Liquefaction Process in Skid-mounted Packages", Applies Thermal Engineering, No. 26, pp. 898-904, 2006
- [8] Seung Taek Oh, Hyun Woo Kim, Ho Saeng Lee, Gyeong Beom Yi, Jung In Yoon, Sang Gyu Lee, Simulation of LNG liquefaction cycle using
- [9] two stage intercooler, Proceedings of KIGAS Spring conference, pp. 225-228, 2009
- [10] H. S. Lee, S. T. Oh, H. W. Kim, J. I. Yoon, G. B. Yi, S. G. Lee, "Analysis of Cryogenic Refrigeration Cycle using Two Stage Intercooler", 5th International Conference on Diffusion in Solids and Liquids, pp. 40-41, 2009
- [11] H. S. Lee, S. T. Oh, H. W. Kim, W. J. Choi, J. I. Yoon and S. G. Lee, Comparison of Performance of Cryogenic Liquefaction Process with Expander, Proceedings of the KSPSE Spring Conference, pp. 250-254, 2009
- [12] Seung-taek Oh, Ho-saeng Lee, Gyeong-Beom Yi, Jung-in Yoon, Sang-gyu Lee, Characteristics of cryogenic liquefaction cycle using two stage compression type, Proceedings of the SAREK Summer Annual Conference, pp. 109, 2009
- [13] C. R. Robert, "The Properties of Gases a Liquid, 4<sup>th</sup> Edition, McGraw-Hill Book Company, 1987