

# The Optimized Cascade PI Controllers of the Generator Control Unit in the Aircraft Power System

W. Chayinthu, K-N. Areerak, K-L. Areerak, and A. Srikaew

**Abstract**—This paper presents the optimal controller design of the generator control unit in the aircraft power system. The adaptive tabu search technique is applied to tune the controller parameters until the best terminal output voltage of generator is achieved. The output response from the system with the controllers designed by the proposed technique is compared with those from the conventional method. The transient simulations using the commercial software package show that the controllers designed from the adaptive tabu search algorithm can provide the better output performance compared with the result from the classical method. The proposed design technique is very flexible and useful for electrical aircraft engineers.

**Keywords**—Cascade PI controllers, DQ method, Adaptive tabu search, Generator control unit, Aircraft power system, Modeling, Simulation, Artificial Intelligence.

## I. INTRODUCTION

**M**ORE Electric Aircraft (MEA) concept [1], [2] is a major trend in aircraft electrical power system (EPS) and results in an increase in electrical loads based on power electronic converters and motor drive systems. In addition, the generator control unit (GCU) in the aircraft system is normally used to stabilize the voltage at the generator feeders. The GCU has cascade PI controllers with an inner field current control loop. The aim of this paper is to present how to design the controller of GCU to achieve the best output voltage performance.

Presently, the artificial intelligence (AI) techniques are widely applied to many works of engineering such as the system identifications using adaptive tabu search (ATS) [3]-[7], the protection design in power system via ATS [8], the active power filter design using genetic algorithm (GA) [9], power loss minimization using particle swarm optimization (PSO) and artificial bee colony (ABC) [10], reactive power optimization for distribution systems based on ant colony optimization (ACO) [11], and etc. According to the literature

W. Chayinthu is master student at the electrical engineering, PEMC research group, School of Electrical Engineering, Suranaree University of Technology Nakhon Ratchasima, 30000, Thailand.

K-N. Areerak is lecturer at the PEMC research group, School of Electrical Engineering, Suranaree University of Technology, Nakhon Ratchasima, 30000, Thailand (corresponding author: kongpan@sut.ac.th)

K-L. Areerak is lecturer at the PEMC research group, School of Electrical Engineering, Suranaree University of Technology, Nakhon Ratchasima, 30000, Thailand.

A. Srikaew is lecturer at the School of Electrical Engineering, Suranaree University of Technology, Nakhon Ratchasima, 30000, Thailand.

review papers, the artificial intelligence technique called ATS is applied to design the controller of GCU for the aircraft power system. The structure of the controller in the paper is the PI cascade having the field current loop control as the inner loop and voltage loop control as the outer loop [12].

Normally, the simple block diagram is used for the controller design using the conventional method in which some system dynamic is ignored. Hence, in the paper, the DQ method [13], [14] is applied to analyze the three-phase diode rectifier to achieve the dynamic model that can explain the behavior of the whole aircraft power system.

In addition, when the controllers are designed via the ATS method, the searching process needs to simulate the power electronic system for each tuned controller parameter until the appropriate parameters are obtained. It is well known that the transient simulations of the power electronic system consume the vast simulation time due to the switching devices in the circuit. Therefore, according to the huge simulation time of the switching devices, the application of AI techniques is not widely applied to design the controller of the power converter. To solve the simulation time problem, the proposed averaging model derived from the DQ method can be also used in the paper instead of the exact topology model. Before using the reported mathematical model, this model has to be compared with the intensive time-domain simulation via the full switching model of software package in terms of accuracy and simulation time.

The comparison results will show later that the DQ mathematical models provide high accuracies in both transient and steady-state responses with the faster simulation time. Hence, the reported model derived from the DQ method is suitable for the optimal controller design via the ATS algorithm. The final results show that the proposed technique using the ATS algorithm with the DQ model can be used to design the controller of GCU in which the better output response is obtained compared with the waveforms from the conventional design method.

The paper is structured as follows. In Section II, the aircraft electrical power system is reviewed. The considered system with deriving the dynamic model by using the DQ modeling methods is explained in Section III. Moreover, the comparison results between the reported model and the full switching model from the commercial software package in terms of accuracy and simulation time are also illustrated in Section III to ensure that the proposed model can explain the dynamic of the whole aircraft power system with the fast simulation time.

The ATS algorithm is briefly explained in Section IV. In Section V, the controller designs using the ATS algorithm are addressed. The simulation results are fully shown in Section

VI. Finally, Section VII concludes and discusses the advantages of the proposed technique for the optimal controller design of the GCU in the aircraft power system.

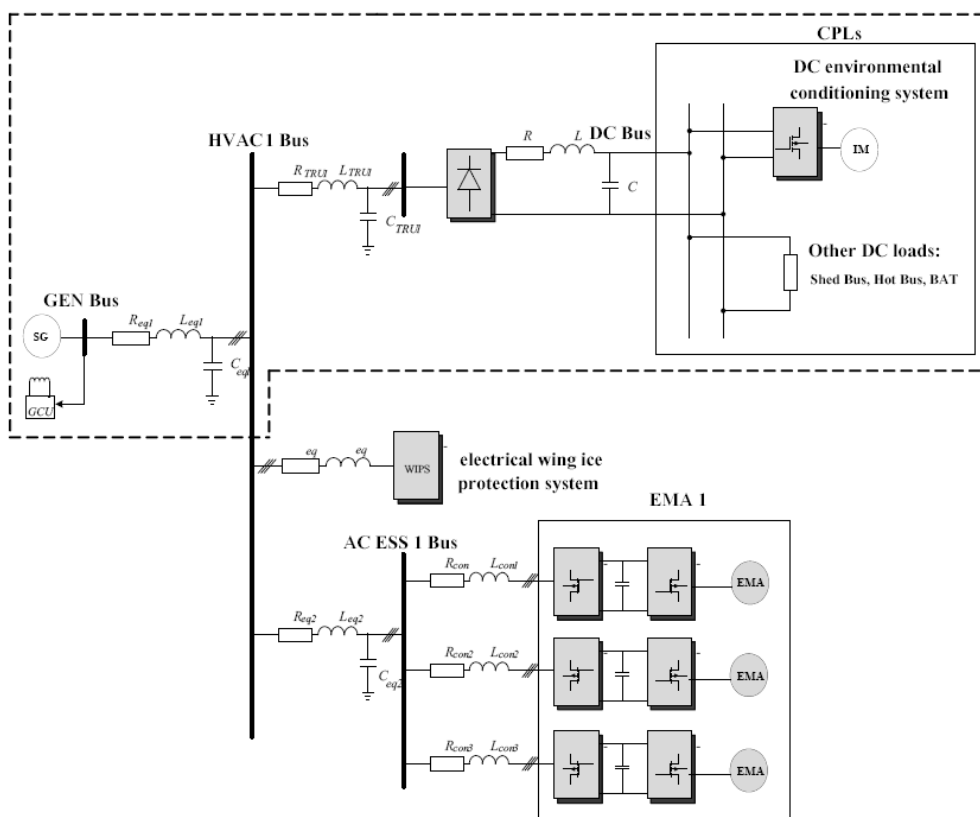

Fig.1 The generalized electrical aircraft power system

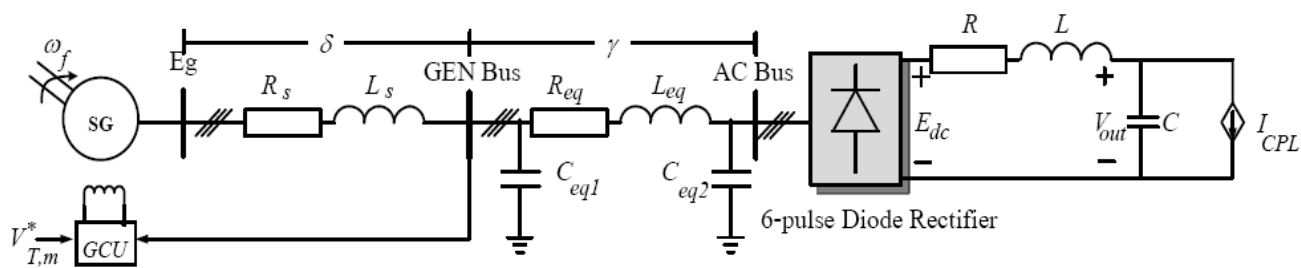

Fig. 2 The considered power system

## II. THE GENERALIZED AIRCRAFT ELECTRICAL POWER SYSTEM

In this paper, the large aircraft power system architecture considered is based on the More Open Electrical Technologies (MOET) Large Aircraft Electrical System Architecture from Airbus France (document WP3.11 Architecture V0 [15]). The generalized electrical aircraft power systems based on the MOET system for ‘one generator’ is shown in Fig. 1. This system diagram is used as a basis for the studies in this paper. The 250 kVA generator feeds 230Vac three-phase power with variable frequency 300-900 Hz onto the HVAC1 bus. The three-phase diode rectifier produces the DC link bus voltage

(HVDC1) +/-270V feeding the electromechanical actuator for an electrical environmental conditioning system (ECSM1) and other DC loads through the HVDC1 bus. The generator also supplies electricity to an electrical wing ice protection system (WIPS1) and the AC ESS1 bus. The AC ESS1 bus supplies a controlled PWM rectifier unit feeding the electromechanical actuators (EMA) for aileron, rudder, flaps, spoilers, and elevator.

## III. THE CONSIDERED SYSTEM

Section II discussed the main elements of aircraft power system architecture as previously shown in Fig. 1. However,

this paper focuses on only the system consisting of the synchronous generator with GCU (SG-GCU), three-phase rectifier, DC-link filters feeding the electromechanical actuator for an electrical environmental conditioning system (ECSM1), and other DC loads through the HVDC1 bus as given in Fig. 1 (dashdot line). The ECSM1 load behaves as the

constant power load (CPL). Interestingly, the ideal CPL can be used to represent ECSM1 for the studies in the paper under the assumption that an infinitely fast controller action of ECSM1 is obtained. Therefore, the considered power system in the paper is depicted in Fig. 2.

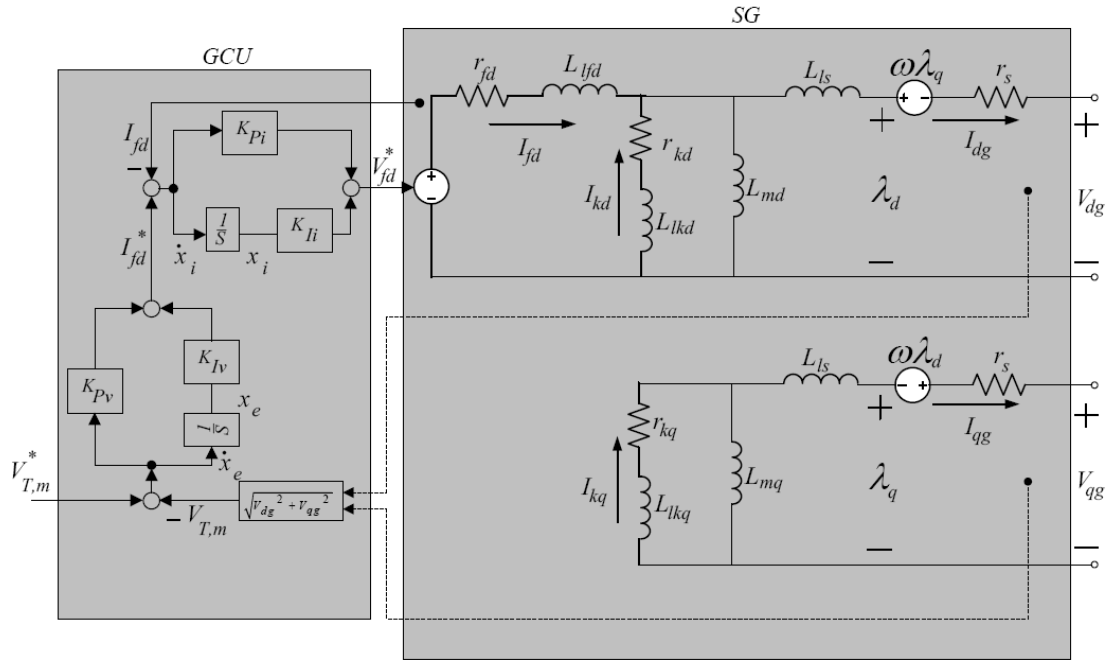

Fig. 3 The SG-GCU model

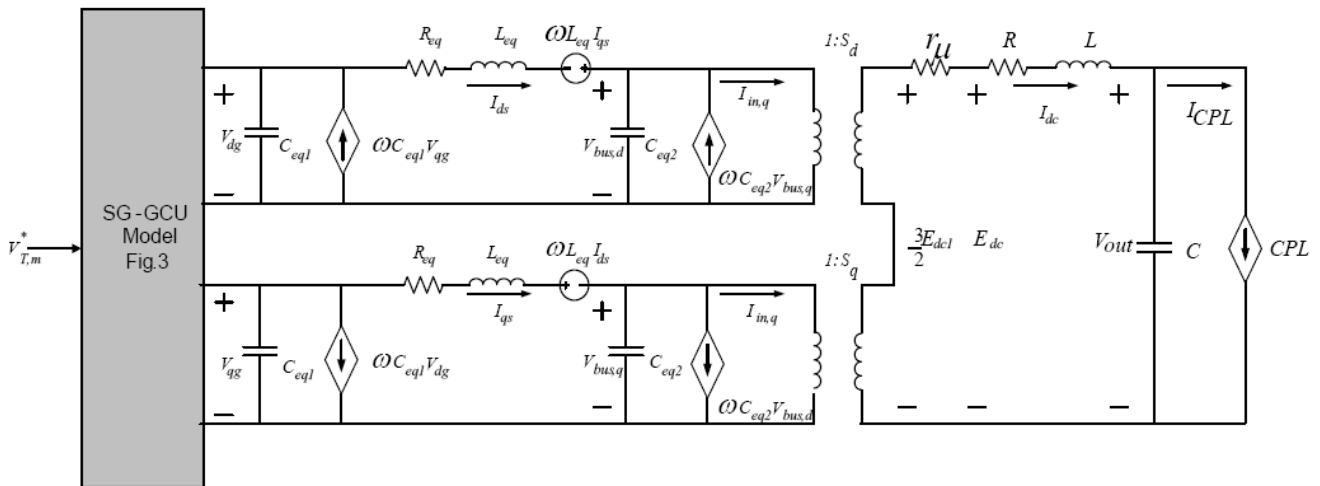

Fig. 4 The equivalent circuit of the studied power system

To combine the dynamic of generator and GCU into the power, it is necessary to consider the synchronous generator (SG) model. It is well known that a SG is normally modelled in the dq reference frame fixed on the rotor [16] and is supplemented by a GCU stabilizing the voltage at the generator feeders. The GCU has a cascade control structure with an inner field current control loop. The shaft speed is

regarded as an input variable. The equivalent circuit of the SG-GCU in the synchronously rotating dq frame is shown in Fig. 3. The parameters  $K_{Pv}$ ,  $K_{Iv}$ ,  $K_{Pi}$ ,  $K_{Ii}$  are the proportional and integral gains of the voltage and current PI controllers.  $V_{T,m}^*$  is the reference for the SG feeder voltage (peak value). The SG-GCU model of Fig. 3 will be used as the dynamic

model for the optimal controller design via the ATS algorithm in Section V.

It is well known that the cable section can be normally modelled on the DQ frame. Moreover, the three-phase diode rectifier can be treated as a transformer on DQ frame based on the DQ approach [14]. As a result, the equivalent circuit of the aircraft power system of Fig. 2 can be represented in the DQ frame as given in Fig. 4.

As can be seen in Fig. 4, the ideal CPL can be considered as a voltage-dependent current source given by (1).

$$I_{CPL} = \frac{P_{CPL}}{V_{out}} \quad (1)$$

Applying the KVL and KCL into the circuit of Fig. 4 with (1), the dynamic model of the considered power system can be expressed as given in (2).

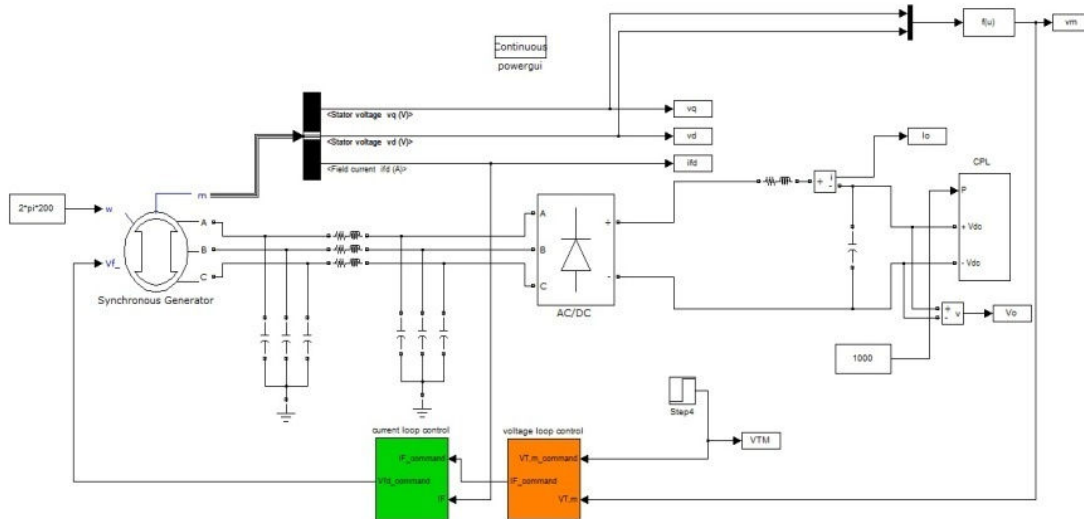

Fig. 5 The full topology model in SPS™ of SIMULINK

The model in (2) can be coded in MATLAB to provide the generator feeder voltage response with the fast simulation time. Notice that the cascade PI controller parameters ( $K_{Pv}$ ,  $K_{Iv}$ ,  $K_{Pi}$ , and  $K_{Ii}$ ) appear in the dynamic model in which the ATS algorithm will search these parameters via the dynamic model of (2). However, before using the dynamic model of (2), the transient simulation from the reported model has to be compared with those from the commercial software package; here is the SimPowerSystem™ (SPS™) of SIMULINK. The exact topology model of SPS™ for the system in Fig. 2 is depicted in Fig. 5. The set of parameters for the system in Fig. 2 is given in Table I [12].

Fig. 6 shows the comparison of the generator voltage responses of the system in Fig. 2 between the exact topology model as given in Fig. 5 and the DQ model as given in (2) to a step change of the voltage command  $V_{T,m}^*$  from 282.84 V (200V<sub>rms</sub>) to 325.27 V (230V<sub>rms</sub>) that occurs at  $t = 0.5$  s. The parameters of PI controllers for Fig. 6 are designed via the conventional method as given in Table I. The details how to design the PI controllers using the conventional method can be found in [12].

From the comparison results of both models, it confirms that the mathematical model of the power system with a GCU derived from the DQ method provide a good accuracy in both transient and steady-state responses. The model can describe the dynamic behavior of the whole aircraft power system.

Moreover, the simulation time when the system was simulated via the proposed model coding in MATLAB requires 1.38 second, while the full topology model of SPS™ consumes 460.15 second. Hence, the proposed DQ model as described in this section is suitable for the optimal controller design of the GCU via the ATS algorithm because the very fast simulation time can be achieved.

$$\begin{aligned}
 &-(L_{ls} + L_{md})\dot{i}_{dg} + L_{md}\dot{i}_{fd} + L_{md}\dot{i}_{kd} = r_s I_{dg} - \omega(L_{ls} + L_{mq})I_{qg} + \omega L_{mq}I_{kq} + V_{dg} \\
 &-L_{md}\dot{i}_{dg} + (L_{lfd} + L_{md})\dot{i}_{fd} + L_{md}\dot{i}_{kd} - K_{Pv}\dot{x}_i = -r_{fd}I_{fd} + K_{Iv}x_i \\
 &-L_{md}\dot{i}_{dg} + L_{md}\dot{i}_{fd} + (L_{lkd} + L_{md})\dot{i}_{kd} = -r_{kd}I_{kd} \\
 &-(L_{ls} + L_{mq})\dot{i}_{qg} + L_{mq}\dot{i}_{kq} = \omega(L_{ls} + L_{md})I_{dg} - \omega L_{md}I_{fd} - \omega L_{md}I_{kd} + r_s I_{qg} + V_{qg} \\
 &-L_{mq}\dot{i}_{qg} + (L_{lkq} + L_{mq})\dot{i}_{kq} = -r_{kq}I_{kq} \\
 &\dot{x}_e = V_{T,m}^* - \sqrt{V_{dg}^2 + V_{qg}^2} - K_{Pv}\dot{x}_e + \dot{x}_i = -I_{fd} + K_{Iv}x_e \\
 &\dot{V}_{dg} = \frac{1}{C_{eq1}}I_{dg} + \omega V_{qg} - \frac{1}{C_{eq1}}I_{ds} \\
 &\dot{V}_{qg} = \frac{1}{C_{eq1}}I_{qg} - \omega V_{dg} - \frac{1}{C_{eq1}}I_{qs} \\
 &\dot{I}_{ds} = \frac{1}{L_{eq}}V_{dg} - \frac{r_{eq}}{L_{eq}}I_{ds} + \omega I_{qs} - \frac{1}{L_{eq}}V_{bus,d} \\
 &\dot{I}_{qs} = \frac{1}{L_{eq}}V_{qg} - \omega I_{ds} - \frac{r_{eq}}{L_{eq}}I_{qs} - \frac{1}{L_{eq}}V_{bus,q} \\
 &\dot{V}_{bus,d} = \frac{1}{C_{eq2}}I_{ds} + \omega V_{bus,q} - \frac{2\sqrt{3}}{\pi} \frac{I_{dc}}{C_{eq2}} \cos(\delta + \gamma) \\
 &\dot{V}_{bus,q} = \frac{1}{C_{eq2}}I_{qs} - \omega V_{bus,d} + \frac{2\sqrt{3}}{\pi} \frac{I_{dc}}{C_{eq2}} \sin(\delta + \gamma) \\
 &\dot{I}_{dc} = \frac{3\sqrt{3}}{\pi L} \cos(\delta + \gamma)V_{bus,d} - \frac{3\sqrt{3}}{\pi L} \sin(\delta + \gamma)V_{bus,q} - \frac{(r_{\mu} + R)}{L} I_{dc} - \frac{1}{L} V_{out} \\
 &\dot{V}_{out} = \frac{1}{C} I_{dc} - \frac{1}{C} \frac{P_{CPL}}{V_{out}}
 \end{aligned} \tag{2}$$

TABLE I  
THE SYSTEM PARAMETERS

Parameter	Value	Description
$V_{T,m}^*$	282.84 to 325.27 V	terminal voltage control
$r_s$	0.0044 $\Omega$	stator resistance
$r_{fd}$	0.068884 $\Omega$	field resistance
$r_{kd}$	0.0142 $\Omega$	d-axis resistance
$r_{kq}$	0.003095 $\Omega$	q-axis resistance
$L_{ls}$	$1.98943 \times 10^{-5}$ H	stator leakage inductance
$L_{lfd}$	$3.28257 \times 10^{-5}$ H	field leakage inductance
$L_{lkd}$	$3.4079 \times 10^{-5}$ H	d-axis leakage inductance
$L_{lkq}$	$1.442739 \times 10^{-4}$ H	q-axis leakage inductance
$L_{md}$	$2.20164 \times 10^{-4}$ H	stator d-axis magnetizing inductance
$L_{mq}$	$1.61807 \times 10^{-4}$ H	stator q-axis magnetizing inductance
$P$	4 poles	number of poles in generator
$\omega$	$2\pi \times 400$ rad/s	source frequency
$\omega_{n,voltage}$	15 Hz	natural frequency of voltage loop in GCU
	$(K_{Pv}=1.78, K_{Iv}=227.02)$	
$\omega_{n,current}$	100 Hz	natural frequency of current loop in GCU
	$(K_{Pv}=0.0487, K_{Iv}=99.88)$	
$R_{eq}$	0.01 $\Omega$	transmission line resistance
$L_{eq}$	$24 \times 10^{-6}$ H	transmission line inductance
$C_{eq1}$ and $C_{eq2}$	$2 \times 10^{-9}$ F	transmission line capacitance
$R$	0.1 $\Omega$	dc link resistance
$L$	$6.5 \times 10^{-3}$ H	dc link inductance
$C$	$500 \times 10^{-6}$ F	dc link capacitance
$P_{CPL}$	1000 W	constant power load

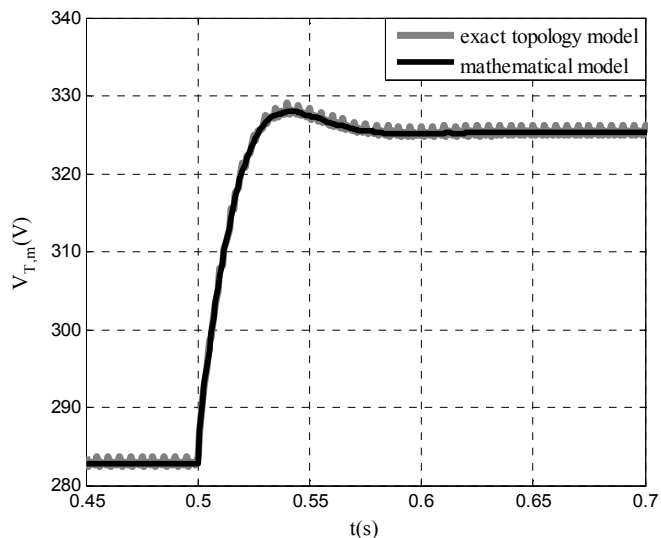

Fig. 6 Response of generator voltage for changing  $V_{T,m}^*$  from 282.84 V to 325.27 V

#### IV. ATS ALGORITHM

The ATS algorithm is improved from the Tabu Search (TS) method by adding two mechanisms namely back-tracking and adaptive search radius. The modified version of the TS method has been named the adaptive tabu search of ATS. The ATS algorithm can be outlined as follows:

- Step 1. Initialize the tabu list  $TL$ , and  $Count$  (a number of search round) = 0.
- Step 2. Randomly select the initial solution  $S_0$  from the search space.  $S_0$  is set as a local minimum and  $S_0 = best\_neighbor$  as shown in Fig. 7.

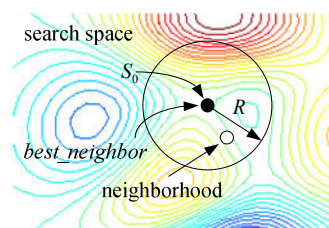

Fig. 7 Random  $S_0$  in search space

Step III: Update  $Count$ , then randomly select  $N$  new solutions from the search space of a radius  $R$ . Let  $S_j(r)$  be a set containing  $N$  solutions as shown in Fig. 7.

Step IV: Compute the cost value of each member of  $S_j(r)$ . Then, choose the best solution and assign it as  $best\_neighbor1$  (see Fig. 8).

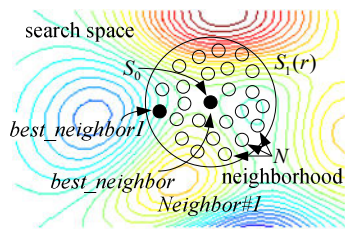

Fig. 8 Neighborhood around  $S_0$

Step V: If  $best\_neighbor1 < best\_neighbor$ , then keep  $best\_neighbor$  in the  $TL$ , set  $best\_neighbor = best\_neighbor1$  (see Fig. 9), and set  $S_0 = best\_neighbor$  (see Fig. 10). Otherwise, put  $best\_neighbor1$  in the  $TL$  instead.

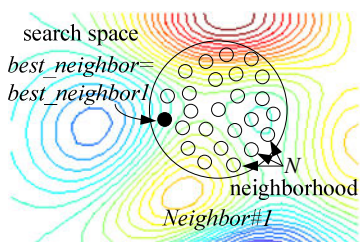

Fig. 9 Assign a new  $best\_neighbor$

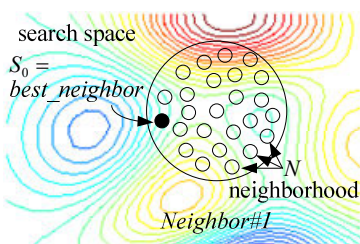

Fig. 10 Assign a new  $S_0$

Step VI: Evaluate the termination criteria ( $TC$ ) and the aspiration criteria ( $AC$ ). If  $Count \geq MAX\_Count$  (the maximum number allowance of search round), stop the searching process. The current best solution is the overall best solution. Otherwise, go back to Step II and start the searching process again until all criteria is satisfied (see Fig. 11).

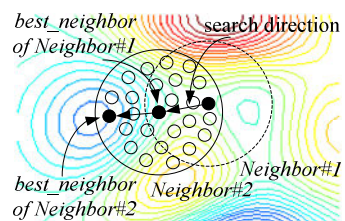

Fig. 11 Searching process in the next iteration

The back-tracking process allows the system to go back and look up the previous solutions in  $TL$ . The better solution is then chosen among the current and the previous solutions. Fig. 12 illustrates details of the back-tracking process.

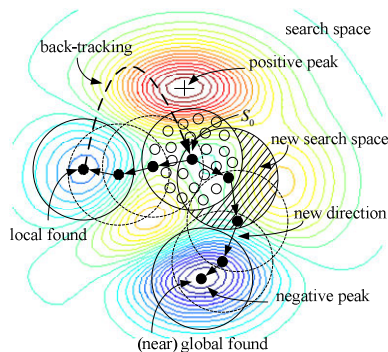

Fig. 12 Back-tracking in ATS algorithm

Given this new search space to explore, the search process is likely to have more chances of escaping from the local optimum. The back-tracking mechanism can be added into Step V to improve the searching performance.

The adaptive radius process as depicted in Fig. 13 decreases the search area during the searching process. The adaptive radius mechanism has been developed to adjust the radius ( $R$ ) by using the cost of the solution. The criterion for adapting the search radius is given in (3).

$$radius_{new} = \frac{radius_{old}}{DF} \quad (3)$$

where  $DF$  is a decreasing factor. The adaptive search radius mechanism can be added into the end of Step VI to improve the searching performance. The more details of ATS algorithm can be found in [3]-[8].

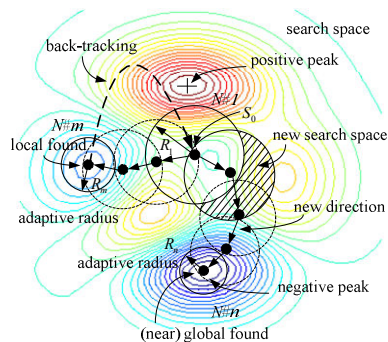

Fig. 13 ATS algorithm with adaptive search radius mechanism

## V. CONTROLLER DESIGN

The block diagram to explain how to search the PI controller parameters of GCU using ATS methods is shown in Fig. 14. The mathematical model derived from the DQ method is used to simulate the system during the search process in which the computational time can considerably reduced.

In Fig. 14, ATS algorithm will search the appropriate controller parameters  $K_{Pv}$ ,  $K_{Iv}$ ,  $K_{Pi}$ ,  $K_{Li}$  in which the objective value ( $W$ ) is defined by

$$W(T_r, T_s, P.O.) = \sigma T_r + \alpha T_s + \gamma P.O. \quad (4)$$

and

$$\sigma + \alpha + \gamma = 1 \quad (5)$$

where

$P.O.$  is the percent overshoot of the generator voltage response.

$T_r$  is the rise time of the generator voltage response.

$T_s$  is the setting time of the generator voltage response.

$\sigma$ ,  $\alpha$ , and  $\gamma$  are the priority coefficients of  $T_r$ ,  $T_s$ , and  $P.O.$ , respectively.

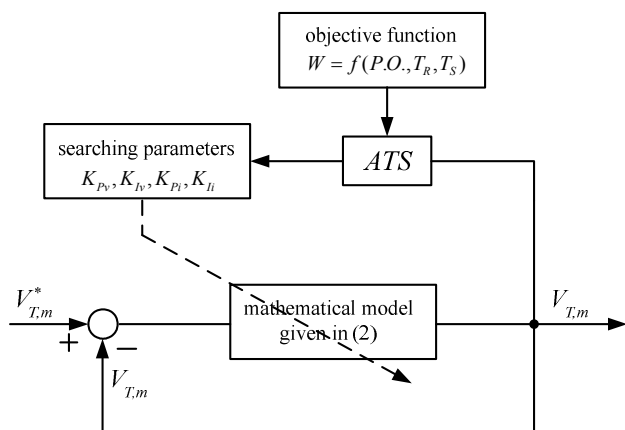

Fig. 14 The ATS method for the cascade PI controller design of GCU

In this paper, the values of  $\sigma$ ,  $\alpha$ , and  $\gamma$  are set to 0.34, 0.33, and 0.33, respectively. The ATS searching method will try to search the best controller parameters until the minimum  $W$  is achieved. It means that the controller parameters from the searching process provide the best performance of the generator voltage response. According to Fig.14, the steps of searching controller parameters by using ATS method are as follows:

- Step 1. Determine the boundary of parameters. In this paper, the upper and lower limits of  $K_{Pv}$ ,  $K_{Iv}$ ,  $K_{Pi}$ ,  $K_{Ii}$  are set to [1 4], [100 300], [0.01 1], [90 300], respectively
- Step 2. Define the initial value for the PI controller parameters by random within the search space as defined from Step 1.
- Step 3. Define the  $R = 4$ , and  $DF = 1.3$ .
- Step 4. Define the cost value, here is  $W$  given by (4) in which it can be calculated from the output response of the objective function as given in the model of (2).
- Step 5. Define the maximum of searching iteration for ATS ( $MAX\_count$ ). In this paper, it is equal to 100 iterations.

## VI. SEARCHING RESULTS

In this section, the system as shown in Fig.2 having the controllers designed by using the ATS algorithm and the conventional methods is simulated by using SPS<sup>TM</sup> in SIMULINK. The aim of the ATS approach is to minimize the  $W$  value to achieve the best generator voltage response. The comparison results of the controller parameters that are designed from the difference methods are given in Table II.

TABLE II  
THE COMPARISON BETWEEN ATS AND CONVENTIONAL METHOD

Controller Parameters	Design Method	
	Conventional Method	ATS Method
$K_{Pv}$	1.78	3.08
$K_{Iv}$	227.02	173.93
$K_{Pi}$	0.0487	0.01
$K_{Ii}$	99.88	288.36
$W$	0.3232	0.0335

According to Table II, the controllers designed from the ATS method provide the minimum  $W$  value compared with those of the conventional method. Fig.15 shows the generator voltage response to a step change of  $V_{T,m}^*$  from 282.84 V to 325.27 V that occurs at  $t = 0.5$  second. The comparison results show that the generator voltage response when the controllers designed by the ATS method is better than that from the conventional method in terms of percent overshoot, rise time and setting time under the changing of command input. In addition, the convergence of  $W$  value during the ATS searching process is depicted in Fig.16.

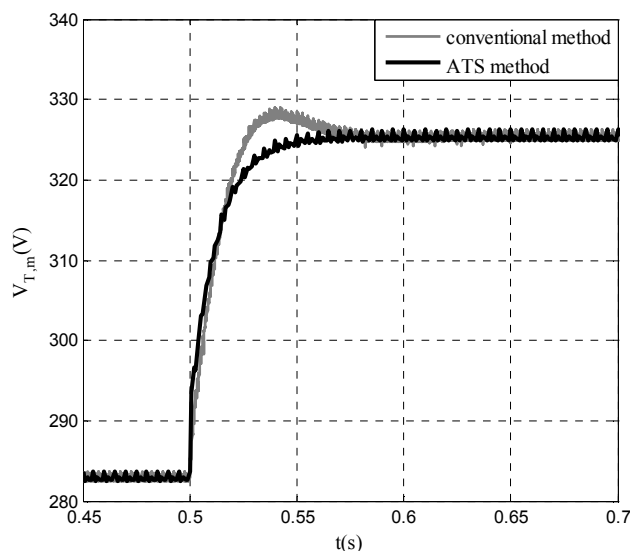

Fig. 15 The comparison results

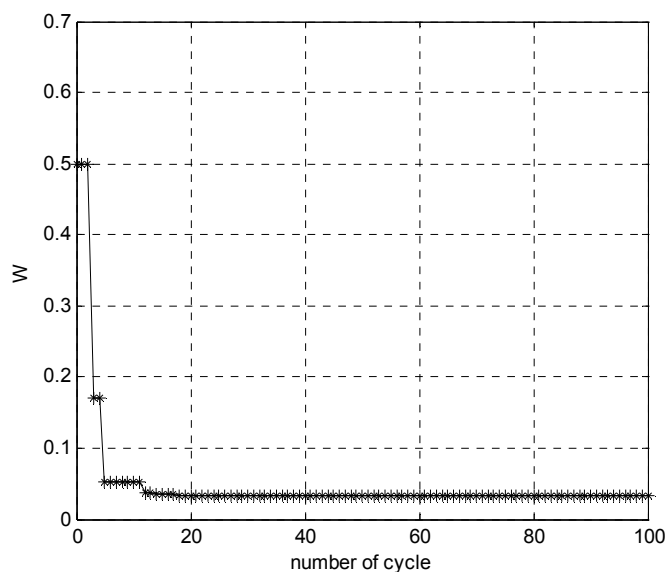

Fig. 16 The convergence of  $W$  value from the ATS searching method

## VII. CONCLUSION

The paper presents the cooperation between the averaging model derived from the DQ method and the ATS algorithm to design the appropriate cascade PI controller parameters of the GCU in the aircraft electrical power system. The resulting output generator voltage response at the generator feeder using the ATS design is better than that of the conventional method. Moreover, the paper also show that the simulation of the switching converter system using the DQ model consumes the faster computational time compared with the simulation time of the exact topology model from the software package. Hence, the reported dynamic model is suitable for the optimal controller design application in which the repeating calculation during the searching process is needed. The proposed design technique is very useful for engineers.

## ACKNOWLEDGMENTS

This work was supported by Suranaree University of Technology (SUT) and by the office of the Higher Education Commission under NRU project of Thailand.

## REFERENCES

- [1] J.A. Rosero, J.A. Ortega, E. Aldabas, and L. Romeral, "Moving Towards a More Electric Aircraft," *IEEE Aerospace and Electronic Systems Magazine*, pp. 3-9, March 2007.
- [2] J.A. Weimer, "The Role of Electric Machines and Drives in the More Electric Aircraft," in *Proc. IEEE International Conference on Electric Machines and Drives (IEMDC'03)*, Madison, Wisconsin, USA, 1-4 June 2003, pp.11-15.
- [3] D. Puangdownreong, K-N. Areerak, A. Srikaew, S. Sujitjorn and P. Totarong, System Identification via Adaptive Tabu Search, In *Proceedings IEEE International Conference on Industrial Technology (ICIT02)*, 2002, pp.915-920.
- [4] S. Sujitjorn, T. Kulworawanichpong and D. Puangdownreong and K-N Areerak, Adaptive Tabu Search and Applications in Engineering Design, *Book Chapters in Integrated Intelligent Systems for Engineering Design* (ed. X. F. Zha and R..J. Howlett), IOS Press, The Netherlands, 2006, pp. 233-257.

- [5] D.Puangdownreong, K-N. Areerak, K-L. Areerak, T. Kulworawanichpong, and S. Sujitjorn, "Application of adaptive tabu search to system identification", *IATED International Conference on Modelling, Identification, and Control (MIC2005)*, Innsbruck, Austria: February 16-18, 2005, pp.178-183.
- [6] T. Kulworawanichpong, K-L. Areerak, K-N. Areerak, P. Pao-la-or, D. Puangdownreong, and S. Sujitjorn, "Dynamic parameter identification of induction motors using intelligent search techniques", *IATED International Conference on Modelling, Identification, and Control (MIC2005)*, Innsbruck, Austria: February 16-18, 2005, pp.328-332.
- [7] T. Kulworawanichpong, K-L. Areerak, K-N. Areerak, and S. Sujitjorn, "Harmonic Identification for Active Power Filters Via Adaptive Tabu Search Method", *LNCS (Lecture Notes in Computer Science)*, Springer-Verlag Heidelberg, vol. 3215, 2004, pp. 687-694.
- [8] K-N. Areerak, T. Kulworawanichpong and S. Sujitjorn, "Moving Towards a New Era of Intelligent Protection through Digital Relaying in Power Systems", *Lecture Notes in Computer Science*, Springer-Verlag Heidelberg, vol. 3213, 2004, pp. 1255-1261.
- [9] T. Narongrit, K-L. Areerak, and K-N. Areerak, "Design of an Active Power Filter using Genetic Algorithm Technique", *The 9<sup>th</sup> WSEAS International Conference on Artificial Intelligent, Knowledge Engineering and Data Bases (AIKED'10)*, Cambridge, United Kingdom: February 20-22, 2010, pp.46-50.
- [10] U. Leeton, D. Uthitsunthorn, U. Kwannetr, N. Sinsuphun, T. Kulworawanichpong, "Power loss minimization using optimal power flow based on particle swarm optimization", *International Conference on Electrical Engineering/Electronics Computer Telecommunications and Information Technology (ECTI-CON)*, Chaing Mai: May 19-21, 2010, pp. 440-444.
- [11] G. Lirui, H. Limin, Z. Liguu, L. Weina, and H. Jie, "Reactive Power Optimization for sidtribution systems based on Dual Population Ant Colony Optimization," in *Proc. 27<sup>th</sup> Chinese Control Conference (CCC 2008)*, China, pp. 89-93.
- [12] K-N. Areerak, T. Wu, S.V. Bozhko, G.M. Asher, and D.W.P. Thomas, "Aircraft Power System Stability Study Including Effect of Voltage Control and Actuators Dynamic," *IEEE Transactions on Aerospace and Electronic Systems*, vol. 47, no. 4, October 2011.
- [13] K-N. Areerak, S.V. Bozhko, G.M. Asher, and D.W.P. Thomas, 2008. "DQ-Transformation Approach for Modelling and Stability Analysis of AC-DC Power System with Controlled PWM Rectifier and Constant Power Loads," in *Proc. 13<sup>th</sup> International Power Electronics and Motion Control Conference (EPE-PEMC 2008)*, Poznan, Poland.
- [14] K. Chaijarunudomrung, K-N. Areerak, and K-L. Areerak, 2010. "Modeling of Three-phase Controlled Rectifier using a DQ method", *2010 International Conference on Advances in Energy Engineering (ICAEE 2010)*, pp.56-59.
- [15] More Open Electrical Technologies (MOET project): <http://www.eurtd.com/moet>.
- [16] P.C. Krause, O. Wasynczuk, and S.D. Sudhoff, "Analysis of Electric Machinery and Drive Systems," John Wiley & Son, Inc, 2002.



**W. Chayinthu** received the B.S. degree in electrical engineering from Suranaree University of Technology (SUT), Nakhon Ratchasima, Thailand, in 2010, where he is currently studying toward the M.Eng. degree in electrical engineering. His main research interests include stability analysis, modeling of power electronic system, constant power loads, and artificial intelligence applications.



**K-N. Areerak** received the B.Eng. and M.Eng. degrees from Suranaree University of Technology (SUT), Nakhon Ratchasima, Thailand, in 2000 and 2001, respectively and the Ph.D. degree from the University of Nottingham, Nottingham, UK., in 2009, all in electrical engineering. In 2002, he was a Lecturer in the Electrical and Electronic Department, Rangsit University, Thailand. Since 2003, he has been a Lecturer in the School of Electrical Engineering, SUT. His main research interests include system identifications, artificial intelligence application, stability analysis of power systems with constant power loads, modeling and control of power electronic based systems, and control theory.





**K-L. Areerak** received the B.Eng, M.Eng, and Ph.D. degrees in electrical engineering from Suranaree University of Technology (SUT), Thailand, in 2000, 2003, and 2007, respectively. Since 2007, he has been a Lecturer and Head of Power Quality Research Unit (PQRU) in the School of Electrical Engineering, SUT. He received the Assistant Professor in Electrical Engineering in 2009. His main research interests include

active power filter, harmonic elimination, AI application, motor drive, and intelligence control system.

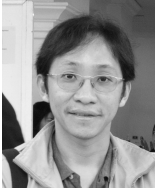

**A. Srikaew** was born in Ubol Ratchathani, Thailand, in 1972. He received the B.Eng. degree from King Mongkut's Institute of Technology Ladkrabang, Bangkok, Thailand, in 1994 and the M.S. and Ph.D. degrees, both in electrical engineering, from Vanderbilt University, Nashville, TN, in 1997 and 2000, respectively. Since 2000, he has been with the School of Electrical Engineering, Institute of Engineering,

Suranaree University of Technology, Nakhon Ratchasima, Thailand, where he is currently an Associate Professor. His main research interests are in the area of computer and robot vision, image processing, neural networks, artificial Intelligence, and intelligent systems.