

# Decoupled, Reduced Order Model for Double Output Induction Generator Using Integral Manifolds and Iterative Separation Theory

M. Sedighzadeh, and A. Rezazadeh

**Abstract**—In this paper presents a technique for developing the computational efficiency in simulating double output induction generators (DOIG) with two rotor circuits where stator transients are to be included. Iterative decomposition is used to separate the flux–Linkage equations into decoupled fast and slow subsystems, after which the model order of the fast subsystems is reduced by neglecting the heavily damped fast transients caused by the second rotor circuit using integral manifolds theory. The two decoupled subsystems along with the equation for the very slowly changing slip constitute a three time-scale model for the machine which resulted in increasing computational speed. Finally, the proposed method of reduced order in this paper is compared with the other conventional methods in linear and nonlinear modes and it is shown that this method is better than the other methods regarding simulation accuracy and speed.

**Keywords**—DOIG, Iterative separation, Integral manifolds, Reduced order.

## I. INTRODUCTION

WIND energy conversion systems have in the past two decades been the object of strong interest as a viable source of electrical energy. Various electromechanical schemes for generating electricity from the wind have been suggested. Variable speed generation schemes offer a number of advantages when compared with fixed speed induction generation. At a given wind speed, higher energy capture is possible by maximizing turbine efficiency through adjustment of shaft speed. Reduction of the torque ripple in the drive train and torsion mode resonance can also be achieved with adjustable speed operation. One such variable speed scheme is the static Kramer drive, also referred to as the sub synchronous converter cascade, which when mechanically driven above synchronous speed will operate as a generator i.e. double output induction generator (DOIG). The system in its conventional form is shown in Fig. 1. It consist of a wound rotor induction machine connected through its slip rings to a three phase diode bridge rectifier and a line commutated inverter connected to the ac supply via a step up

transformer[1]. The double output induction generator is modeled based on particular type of application. For instance, in transient stability studies of power systems, high-frequency oscillatory transients of the active and reactive Electromechanical transients of double output induction generators (DOIG) are usually simulated digitally and the degree of detail of the machine model used for the simulation powers caused by the machine stator winding are usually ignored.

However, there are several applications such as power system studies of short circuits, relay coordination, sub synchronous resonance, switching transients and shaft stresses, where machine stator (and network) transients should be included [2].

In this paper, a procedure is presented to reduce computational effort when stator transients of DOIG's are be included. The method is developed by judicious interpretation of the physical phenomena involved, decomposition of the transients into fast and slow parts, and model order reduction by neglecting heavily damped fast transients using integral manifolds.

Large DOIG's are generally equipped with a two rotor circuits (double cage) or deep-bar rotor. In the following, a double-cage DOIG will be considered.

The resulting model, however, can also be applied with some degree of approximation to DOIG's with deep-bar rotors since an equivalent double cage can always be found which provides the machine with an admittance locus closely fitting that of a deep-bar induction machine [3].

In [4], some of the methodologies currently available to reduce the order of induction machines models have been introduced.

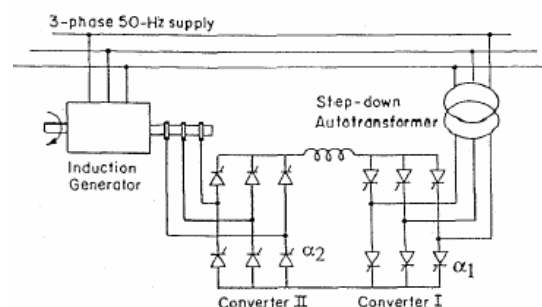

Fig. 1 Schematic representation of DOIG

Manuscript received October 6, 2007.

Authors are with Faculty of Electrical and Computer Engineering, Shahid Beheshti University, Tehran, 1983963113, Iran (phone: +98-21-29902290; fax: +98-21-22431804; e-mail: m\_sedighi@sbu.ac.ir).

One of the known techniques used in power system as singular perturbations decomposes the system according to its fast and slow dynamics and then lowers the model order by first neglecting the fast dynamics phenomena [4]. The effect of fast dynamics are then reintroduced as boundary layer correction calculated in separated time scales, which leads to correct static gains.

The technique known in the literature is the concept of iterative separation [5] and integral manifolds, a nonlinear generalization of the notion of invariant subspace in linear systems [6]. This paper employs the manifold concept as a tool for reduced order modeling and decomposition of DOIG.

## II. DOIG FULL ORDER MODEL

In this paragraph, the equations describing the subsystems of a variable speed wind turbine with DOIG and converter (rectifier and inverter) will be developed. The equations for the rotor, the generator and the converter will be given here. The equations have been developed using the following assumptions:

- 1-All rotating mass is represented by one element: The so-called 'lumped-mass' representation. Elastic shafts and resulting torsion forces are neglected.
- 2-Magnetic saturation in the DOIG is neglected.
- 3-Dynamic phenomena in the converter are neglected

Using the subscripts 1,2 and 3 to refer to the stator winding, first and second circuits respectively, the d,q equations in per-unit for the flux linkages of a DOIG with two rotor circuit can be expressed in the synchronously revolving reference frame [7] as follows (see appendix for notations and parameters not defined in the text):

$$\begin{aligned} \dot{\varphi}_{1d} &= -(r_1 l_{11} / l) \varphi_{1d} + \omega \varphi_{1q} + (r_1 l_{21}^2 / l) \varphi_{2d} + (r_1 l_{21}^2 / l) \varphi_{3d} + v_{1d} \\ \dot{\varphi}_{1q} &= -\omega \varphi_{1d} - (r_1 l_{11} / l) \varphi_{1q} + (r_1 l_{21}^2 / l) \varphi_{2q} + (r_1 l_{21}^2 / l) \varphi_{3q} + v_{1q} \end{aligned} \quad (1)$$

$$\begin{aligned} \dot{\varphi}_{2d} &= [(r_2 + R_c)(l_{21}^2 / l) + R_c l_{23}^2 / l] \varphi_{1d} - [(r_2 + R_c)(l_{22} / l) - l_{1m}^2 R_c / l] \varphi_{2d} \\ &+ s \omega \varphi_{2q} + [(r_2 + R_c)(l_{21}^2 / l) + R_c l_{23}^2 / l] \varphi_{3d} + v_{2d} \end{aligned} \quad (2)$$

$$\begin{aligned} \dot{\varphi}_{2q} &= [(r_2 + R_c)(l_{21}^2 / l) + R_c l_{23}^2 / l] \varphi_{1q} - s \omega \varphi_{2d} \\ &- [(r_2 + R_c)(l_{22} / l) - l_{1m}^2 R_c / l] \varphi_{2q} + [(r_2 + R_c)(l_{21}^2 / l) + R_c l_{23}^2 / l] \varphi_{3q} + v_{2q} \\ \tau_3 \dot{\varphi}_{3d} &= [(1 + R_c / r_3)(l_{21}^2 / l) + R_c l_{23}^2 / r_3] \varphi_{1d} + [(1 + R_c / r_3)(l_{1m}^2 / l) \\ &- R_c l_{22} / r_3] \varphi_{2d} - [(1 + R_c / r_3)(l_{33} / l) + R_c l_{31}^2 / r_3] \varphi_{3d} + (s \omega l / r_3) \varphi_{3q} \end{aligned} \quad (3)$$

$$\begin{aligned} \tau_3 \dot{\varphi}_{3q} &= [(1 + R_c / r_3)(l_{21}^2 / l) + R_c l_{23}^2 / r_3] \varphi_{1q} + [(1 + R_c / r_3)(l_{1m}^2 / l) \\ &- R_c l_{22} / r_3] \varphi_{2q} - (s \omega l / r_3) \varphi_{3d} - [(1 + R_c / r_3)(l_{33} / l) + R_c l_{31}^2 / r_3] \varphi_{3q} \end{aligned}$$

$$T_e = (l_{21}^2 / l)(\varphi_{1d} \varphi_{2q} - \varphi_{1q} \varphi_{2d}) + (l_{21}^2 / l)(\varphi_{1d} \varphi_{3q} - \varphi_{1q} \varphi_{3d}) \quad (4)$$

Where

$$\tau_3 = l / r_3 \quad (5)$$

Due to existence of the common end-ring in the double cage DOIG used in this study, equations (1)-(3) contain terms which describe voltage drop on common resistance  $R_c$ .

$$s^* = (\omega / 2H)(T_e - T_l) \quad (6)$$

$$T_l = K \omega_r^2 \quad (7)$$

Where  $K$  corresponds to full load.

The variable  $\varphi_1$  and  $\varphi_3$  contain mainly fast transients whereas  $\varphi_2$  is predominantly slow. Since the fast transient parts of  $\varphi_2$  are small compared with its slow part as well as with the fast transient parts of  $\varphi_1$  and  $\varphi_3$ , equations (1), (2) and (3) are state separable, i.e. the fast and slow modes can be separated by an iterative process. This will convert the sixth order flux-linkage equations into a set of simultaneous fourth order equations for the fast transients and a set of simultaneous second order equations for the slow transients. These separated sets of equations, along with the equation for the very slowly changing slip, provide a simulation model which will reduce the computational effort if the integration time steps for the three subsystems are properly selected.

## III. ITERATIVE SEPARATION OF SLOW AND FAST MODES [11]

Grouping the machine flux-linkages into the predominantly fast changing flux linkages of the stator winding and second rotor circuit

$$\varphi_{ss} = [\varphi_{1d} \dots \varphi_{1q} \dots \varphi_{3d} \dots \varphi_{3q}] \quad (8)$$

And the slowly varying flux-linkages of the first rotor circuit are written:

$$\varphi_r = [\varphi_{2d} \dots \varphi_{2q}] \quad (9)$$

Equations (1), (2) and (3) can be written in partitioned form as

$$\begin{bmatrix} \dot{\varphi}_{ss} \\ \dot{\varphi}_r \end{bmatrix} = \begin{bmatrix} A & \dots & B \\ C & \dots & D \end{bmatrix} \begin{bmatrix} \varphi_{ss} \\ \varphi_r \end{bmatrix} + \begin{bmatrix} v_1 \\ v_2 \end{bmatrix} \quad (10)$$

$$v_1 = \begin{bmatrix} v_{1d} \\ v_{1q} \\ 0 \\ 0 \end{bmatrix} \dots v_2 = \begin{bmatrix} v_{2d} \\ v_{2q} \end{bmatrix}$$

To better isolate the fast and slow modes from each other, it is necessary to reduce the effect of the slowly varying part of  $\varphi_r$  on  $\varphi_{ss}$ , and the effect of the fast varying part of  $\varphi_{ss}$  on  $\varphi_r$ . This is equivalent to reducing the coupling matrices  $B$  and  $C$  in equation (10), which will be carried out iteratively.

First, we define  $\varphi_{ss}^0$ . As the quasi-steady state valued for  $\varphi_{ss}$  by setting  $\dot{\varphi}_{ss}^0$  to zero in equation (10) gives

$$\varphi_{ss}^0 = -A^{-1} B \varphi_r - A^{-1} v_1 \quad (11)$$

Thus,  $\varphi_{ss}^0$  is the value of  $\varphi_{ss}$  if  $\varphi_{ss}$  were instantly damped. To remove the slowly varying part of  $\varphi_{ss}$ ,  $\mu_1$  is introduced as the difference between  $\varphi_{ss}$  and  $\varphi_{ss}^0$  from (11):

$$\mu_1 = \varphi_{ss} + A^{-1}B\varphi_r + A^{-1}v_1 \quad (12)$$

Substituting  $\varphi_{ss}$  from (12) in (10) and ignoring the  $s^{\bullet}$  terms in  $A^{\bullet}$  (since, as noted earlier,  $s$  is very slowly varying), yield

$$\mu_1^{\bullet} - A^{-1}v_1^{\bullet} = A_1\mu_1 + B_1\varphi_r - A^{-1}BCA^{-1}v_1 \quad (13)$$

And

$$\varphi_r^{\bullet} = C\mu_1 + D_1\varphi_r + v_2 - CA^{-1}v_1 \quad (14)$$

With

$$A_1 = A + A^{-1}BC \dots B_1 = A^{-1}BD_1 \dots D_1 = D - CA^{-1}B \quad (15)$$

Introducing

$$\eta_1 = \mu_1 - A^{-1}v_1 \quad (16)$$

Or, considering (12),

$$\eta_1 = \varphi_{ss} + A^{-1}B\varphi_r \quad (17)$$

Where  $\eta_1$  is as fast as  $\mu_1$  and equations (13) and (14) are rewritten

$$\eta_1^{\bullet} = A_1\eta_1 + B_1\varphi_r + v_1 \quad (18)$$

And

$$\varphi_r^{\bullet} = C\eta_1 + D_1\varphi_r + v_2 \quad (19)$$

Equations (18) and (19) are similar to (10) except that  $\eta_1$  has replaced  $\varphi_{ss}$  and the effect of  $\varphi_r$  on the  $\eta_1^{\bullet}$  equation is attenuated since it can be shown that the elements of  $B_1$  are smaller than those of  $B$ .

To further reduce the effect of  $\varphi_r$ , the attenuation process is repeated by defining, as in (17),

$$\eta_2 = \eta_1 + A_1^{-1}B_1\varphi_r \quad (20)$$

And subsequent substitution of  $\eta_1$  from (20) into (18) and (19):

$$\eta_2^{\bullet} = A_1\eta_2 + B_2\varphi_r + v_1 \quad (21)$$

$$\varphi_r^{\bullet} = C\eta_2 + D_2\varphi_r + v_2 \quad (22)$$

Where

$$A_2 = A_1 + A_1^{-1}B_1C \dots B_2 = A_1^{-1}B_1D_2 \dots D_2 = D_1 - CA_1^{-1}B_1 \quad (23)$$

Equations (21) and (22) have replaced (18) and (19) but now the effect of  $\varphi_r$  is more attenuated, because  $B_2$  is smaller than  $B_1$ .

In general, if the attenuation process is carried out  $n$  times, the resulting equations are

$$\eta_n^{\bullet} = A_n\eta_n + B_n\varphi_r + v_1 \quad (24)$$

and

$$\varphi_r^{\bullet} = C\eta_n + D_n\varphi_r + v_2 \quad (25)$$

Where

$$\eta_n = \eta_{n-1} + A_{n-1}^{-1}B_{n-1}\varphi_r \quad (26)$$

With

$$A_n = A_{n-1} + A_{n-1}^{-1}B_{n-1}C \dots B_n = A_{n-1}^{-1}B_{n-1}D_n \dots D_n = D_{n-1} - CA_{n-1}^{-1}B_{n-1} \quad (27)$$

The coupling of the fast variable  $\eta_n$  into the slow variable  $\varphi_r$  equation in (25) is still  $C$ . To reduce this coupling by iterative separation  $\eta_n$  is eliminated in equations (24) and (25):

$$\varphi_r^{\bullet} - CA_n^{-1}\eta_n^{\bullet} = (D_n - CA_n^{-1}B_n)\varphi_r - CA_n^{-1}v_1 + v_2 \quad (28)$$

The right hand side of (28) contains less of the fast transients than the right hand side of (25) since  $\eta_n$  is eliminated. Thus, the variable

$$\sigma_1 = \varphi_r - CA_n^{-1}\eta_n \quad (29)$$

Contains less fast transients than  $\varphi_r$ , substituting  $\varphi_r$  from (29) into (24) and (25), and ignoring the  $s^{\bullet}$  terms in  $A^{\bullet}$  yield

$$\eta_n^{\bullet} = A_n\eta_n + B_n\sigma_1 + v_1 \quad (30)$$

And

$$\sigma_1^{\bullet} = C\eta_n + D_n\sigma_1 - F_n v_1 + v_2 \quad (31)$$

With

$$A_{n1} = A_n + B_nCA_n^{-1} \dots C_1 = D_{n1}CA_n^{-1} \dots D_{n1} = D_n - CA_n^{-1}B_n \dots F_{n1} = CA_n^{-1}$$

Carrying out the iterative decoupling process of the fast transients from the slow variable equation  $m$  times results in

$$\eta_m^{\bullet} = A_{mm}\eta_m + B_m\sigma_m + v_1 \quad (32)$$

And

$$\sigma_m^{\bullet} = C_m\eta_m + D_m\sigma_m - F_{mm}v_1 + v_2 \quad (33)$$

Where

$$\sigma_m = \sigma_{m-1} - C_{m-1}A_{mm-1}^{-1}\eta_m \quad (34)$$

With

$$A_{mm} = A_{mm-1} + B_mC_{m-1}A_{mm-1}^{-1} \dots C_m = D_{mm}C_{m-1}A_{mm-1}^{-1} \dots D_{mm} = D_{mm-1} - C_{m-1}A_{mm-1}^{-1}B_m \dots F_{mm} = C_{m-1}A_{mm-1}^{-1} \dots F_{m0} = 0 \quad (35)$$

It can be shown that at sufficiently low absolute slip values, the elements of  $B_n$  and  $C_m$  approach zero as  $n$  and  $m$  go to infinity for typical machine parameters. Generally, the convergence of this iteration process is quite fast. If  $B_n$  and  $C_m$  are sufficiently small, equations (32) and (33) can be simulated in decoupled from as

$$\eta_m^{\bullet} = A_{mm}\eta_m + v_1 \quad (36)$$

And

$$\sigma_m^* = D_{nm}\sigma_m - F_{nm}v_1 + v_2 \quad (37)$$

However, a small steady-state error is created by ignoring  $B_n$  and  $C_m$ . This can be compensated by inserting the steady state variables  $\eta_n^o$  and  $\varepsilon_m^o$  in (36) and (37) as follows:

$$\eta_n^* = A_{nm}\eta_n + B_n\sigma_m^o + v_1 \quad (38)$$

$$\sigma_m^* = C_m\eta_n^o + D_{nm}\sigma_m - F_{nm}v_1 + v_2 \quad (39)$$

From which  $\eta_n^o$  and  $\eta_n^o$  can be found by setting  $\eta_n^* = \varepsilon_m^* = 0$ . The result can be written as

$$\eta_n^* = A_{nm}\eta_n + G_{nm}v_1 \quad (40)$$

And

$$\sigma_m^* = D_{nm}\sigma_m - H_{nm}v_1 + v_2 \quad (41)$$

Where

$$G_{nm} = B_n D_{nm}^{-1} H_{nm} + I \dots H_{nm} = C_m A_{nm}^{-1} G_{nm} + F_{nm} \quad (42)$$

From which  $G_{nm}$  and  $H_{nm}$  can be solved.

#### IV. NEGLECTING HEAVILY DAMPED FAST TRANSIENTS USING INTEGRAL MANIFOLDS

##### A. Integral Manifolds Theory [6, 7]

The term “manifold” in this paper refers to a functional relationship between variables. For example, a manifold for  $z$  as a function of  $x$  is simply another term for the expression.

$$z = h(x) \quad (43)$$

When  $x$  is a scalar, the manifold is a line when plotted in the  $x, z$  plane. When the variable,  $x$  is two dimensional, the manifold is a surface.

To define an integral manifold, we have to introduce a multidimensional dynamic model of the form

$$\frac{dx}{dt} = f(x, z) \dots \dots \dots x(0) = x^0 \quad (44)$$

$$\frac{dz}{dt} = g(x, z) \dots \dots \dots z(0) = z^0 \quad (45)$$

An integral manifold for  $z$  as a function of  $x$  is a manifold

$$z = h(x) \quad (46)$$

Which satisfies the differential equation for variable,  $z$ . Thus, if it satisfies following equation,  $h(x)$  is an integral manifold of (44)-(45)

$$\frac{\partial h}{\partial x} f(x, h) = g(x, h) \quad (47)$$

If the initial conditions on the variable,  $x$  and variable,  $z$  lie on the manifold ( $z^0 = h(x^0)$ ), then the integral manifold is an exact solution of the differential equation (45), and the following reduced order model is exact.

$$\frac{dx}{dt} = f(x, h(x)) \dots \dots \dots x(0) = x^0 \quad (48)$$

##### B. Application to DOIG

The integral manifolds theory outlined in the previous section was applied to the case of the DOIG detailed model.

Lets equation (40) for the fast transients be partitioned as

$$\begin{bmatrix} \eta_{sw}^* \\ \eta_{sc}^* \end{bmatrix} = \begin{bmatrix} K \dots \dots L \\ P \dots \dots Q \end{bmatrix} \begin{bmatrix} \eta_{sw} \\ \eta_{sc} \end{bmatrix} + \begin{bmatrix} R \\ T \end{bmatrix} v_1 \quad (49)$$

Here the predominant fast transients in  $\eta_{sw}$  caused by the natural mode associated with the stator winding flux – linkage  $\phi_1$ , are lightly damped and highly oscillatory. The predominant fast transients in  $\eta_{sc}$ , caused by the natural mode associated with the second circuits rotor cage flux-linkage,  $\phi_3$ , are heavily damped. In this section, the state variable  $\eta_{sc}$  related to second circuits rotor is eliminated using integral manifolds.

According to integral manifolds theory that is defined in [13] variables  $x$  and  $z$

$$\begin{aligned} x &= [\eta_{sw} \dots \sigma_m \dots s] \\ z &= [\eta_{sc}] \end{aligned} \quad (50)$$

$$\varepsilon = \tau_3 = l / r_3 \quad (51)$$

and  
 When  $\tau_3$  is non zero but small, we let  $\tau_3 = \varepsilon$  and search for the unknown functions:

$$\eta_{sc} = h(\eta_{sw}, \sigma_m, s, \varepsilon) \quad (52)$$

$$\text{Using two power series in } \varepsilon \text{ about } \varepsilon = 0, \text{ namely,} \\ h = h_0 + \varepsilon h_1 + \varepsilon^2 h_2 + \dots \quad (53)$$

To find the terms  $h_0, h_1, \dots$  of the series, we use the fact the function  $h$  must satisfies (47). In view of (46), these give,

$$\varepsilon \frac{\partial h}{\partial \eta_{sw}} \cdot \frac{d\eta_{sw}}{dt} + \varepsilon \frac{\partial h}{\partial \sigma_m} \cdot \frac{d\sigma_m}{dt} + \varepsilon \frac{\partial h}{\partial s} \cdot \frac{ds}{dt} = (l / r_3)(P\eta_{sw} + Qh + Tv_1) \quad (54)$$

Which are partial deferential equations that must be satisfied by the series (53) as identities for all  $\varepsilon$  near to zero. With using (6), (37) and (49) and substituting into (54), we obtain expressions in terms of  $\varepsilon^0, \varepsilon^1, \varepsilon^2, \dots$ .

Equating coefficients of  $\varepsilon$  gives the identities to be satisfied by each  $h_i$ . Due to decompose  $\eta_n$  and  $\sigma_m$ , the second term of left side (54) is zero. Also  $s$  is very slowly in compare with other variables, so the third term of left side (54) is zero. For  $h_0$  we equate all the terms not containing  $\varepsilon$  giving,

$$h_0 = -Q^{-1}P\eta_{sw} - Q^{-1}Tv_1 \quad (55)$$

Equating coefficients of  $\varepsilon^1$  gives

$$h_1 = -(r_3 / l)Q^{-1}P[(K - LQ^{-1}P)\eta_{sw} + (R - LQ^{-1}T)v_1]$$

This process can be continued to obtain higher order terms if desired. Stopping with two terms, the approximate manifold expression is,

$$h = \eta_{sc} = h_0 + \epsilon h_1 \quad (56)$$

Therefore dynamic equations for the state variable related to second circuits rotor,  $\eta_{sc}^{\bullet}$  are converted to algebraic equations and detailed model is reduced order to fifth order. Equations (49) are rewritten as following:

$$\eta_{sw}^{\bullet} = K'' \eta_{sw} + R'' v_1 \quad (57)$$

Where

$$K'' = K + LQ^{-1}P(I - K - LQ^{-1}P) \quad (58)$$

And

$$R'' = -LQ^{-1}T + LQ^{-1}P(R - LQ^{-1}T) + R \quad (59)$$

Thus, equations (6), (37) and (57) constitute a partially decomposed, reduced order model (fifth order) for the DOIG.

#### V. LINEARIZATION NEW MODEL

Each of the two nonlinear models full order and fifth order can be linear around an operating point if it is assume that the variables have sufficiently small deviations from the operating point. For example this assumption is made in dynamic stability studies of power systems where it is customary to use a linear model so that linear system analysis methods can be conveniently applied.

The linearization process could be directly applied to the fifth order DOIG model. However, the coefficients of the resulting equations, particularly for the fifth-order model, would have rather complicated algebraic expressions. An equivalent approach is through linearization the complete seventh order model and then numerically deriving the linear fifth model by following process. Let the linear and decomposed seventh-order equations be partitioned as

$$\Delta \eta_n^{\bullet} = A_{nmo} \Delta \eta_n + G_{nmo} \Delta v_1 \quad (60)$$

$$\Delta \sigma_m^{\bullet} = D_{nmo} \Delta \sigma_m - H_{nmo} \Delta v_1 + \Delta v_2 \quad (61)$$

$$\Delta s^{\bullet} = f(\Delta \rho_d, \Delta \rho_q, \Delta \rho_{2d}, \Delta \rho_{2q}, \Delta \rho_{3d}, \Delta \rho_{3q}, \Delta s) \quad (62)$$

Where  $\Delta$  is small deviation in operating point. Linear equations (49) rewritten as

$$\Delta \eta_{sw}^{\bullet} = K_O \Delta \eta_{sw} + L_O \Delta \eta_{sc} + R_O \Delta v_1 \quad (63)$$

$$\Delta \eta_{sc}^{\bullet} = P_O \Delta \eta_{sw} + Q_O \Delta \eta_{sc} + T_O \Delta v_1 \quad (64)$$

Thus, for the fifth-order model,  $\Delta \eta_{sc}$  represents the second rotor circuit flux linkage. For a linear time invariant system, the integral manifold is sought in the form [6]

$$\Delta \eta_{sc} = E \Delta \eta_{sw} + q(\Delta v_1) \quad (65)$$

The substitution (65) in to (63) and (64) yields:

$$\begin{aligned} E[K_O \Delta \eta_{sw} + L_O[E \Delta \eta_{sw} + q(\Delta v_1)] + R_O \Delta v_1] = \\ Q_O[E \Delta \eta_{sw} + q(\Delta v_1)] + P_O \Delta \eta_{sw} + T_O \Delta v_1 \end{aligned} \quad (66)$$

Collecting the  $\Delta \eta_{sw}$ -dependent terms we require that the constant matrix  $E$  be a solution of

$$EK_O - Q_O E + EL_O E - P_O = 0 \quad (67)$$

With such a  $E$ , the  $\Delta v_1$ -dependent terms require that

$$[Q_O - EL_O]q(\Delta v_1) + [T_O - ER_O]\Delta v_1 = 0 \quad (68)$$

Which provided  $(Q_O - EL_O)^{-1}$  exists, is satisfies by

$$q(\Delta v_1) = (Q_O - EL_O)^{-1}[T_O - ER_O]\Delta v_1 \quad (69)$$

The description of the system (63) and (64) restricted to the manifold (65) is given by the reduced order model:

$$\Delta \eta_{sw}^{\bullet} = [K_O + EL_O]\Delta \eta_{sw} + [L_O(Q_O - EL_O)^{-1}(T_O - ER_O) + R_O]\Delta v_1 \quad (70)$$

If initial conditions for  $\Delta \eta_{sw}$  and  $\Delta \eta_{sc}$  satisfies in (65), thus, reduced order model is (70), but if initial conditions don't meet manifold conditions, we seek expression similar to nonlinear model.

The accuracy of the proposed linear reduced-order model can be verified by comparing the sets of Eigen values of the linear full-order model, linear fifth-order model(singular perturbation method) and linear fifth-order model( proposed method). The sets of eigenvalues are listed in Table I.

#### VI. SIMULATION ALGORITHM

The decomposed, reduced order model consists of three sets of differential equations, i.e., (57) for the fast state  $\eta_{sw}$ , (37) for the slow state  $\sigma_m$ , and (6) for very slow slip  $s$ . These can be solved with different integration time steps, say  $\Delta t$ ,  $M * \Delta t$  and  $N * \Delta t$  respectively. The integers  $M$  and  $N$  ( $N > M > 1$ , and  $(N/M)$  is an integer) are selected in accordance with the response speeds of the associated states.

At first the fast and slow variables are initialized as  $\eta_{sw}^o$  and  $\sigma_m^o$ , the matrices  $D_{nm}$ ,  $H_{nm}$ ,  $R''$  and  $K''$  are formed using initial slip value. Then,  $\eta_{sw}(t + \Delta t)$  is computed  $M$  times using time step  $\Delta t$ . Next,  $\sigma_m(t + \Delta t)$  is calculated using time step  $M * \Delta t$ . This set of variables is calculated  $(M/N)$  times. Then the slip,  $s(t + N * \Delta t)$ , is determined using time step  $N * \Delta t$ , along with updating the matrices  $D_{nm}$ ,  $H_{nm}$ ,  $R''$  and  $K''$  with the new slip.

#### VII. MODEL VALIDATION

To validate the procedure, the decomposed, reduced order new model response was compared to that of the original full order, reduced order model using singular perturbation theory and reduced order with quasi steady state i.e.  $\varphi_3^{\bullet} = 0$ . The model parameters listed in [7]. The iterative separation procedure was carried out for only two full iteration, i.e.  $n=m=2$ . The basic time step  $\Delta t$  for the fast variable and for the full order model was taken equal to 0.0004 s. furthermore,  $M$  and  $N$  were selected to be 5 and 50 respectively so that the slow variable time step is 0.002 s and the time step for the slip is 0.02 s. Fourth order Runge kutta integration method was used. The

relevant variables are generally the instantaneous active and reactive power flows, at the machine terminals, speed and electromagnetic torque obtained respectively from

$$P = v_{1d}i_{1d} + v_{1q}i_{1q} + v_{2d}i_{2d} + v_{2q}i_{2q} \quad (71)$$

$$Q = v_{1q}i_{1d} - v_{1d}i_{1q} + v_{2q}i_{2d} - v_{2d}i_{2q} \quad (72)$$

$$\omega_r = (1-s)\omega \quad (73)$$

A start-up corresponding to mechanical torque increase 0 to %100 is simulated for the different nonlinear models and the behaviors of active power, reactive power, speed and electromagnetic torque are shown in Fig. 2.

The second selected case study targets the simulation of a fault in the a.c. system which causes the voltage dip in generator terminal at 50 msec and normal operation occurring 500 msec after which normal operation voltages was restored. Fig. 3 shows the active and reactive power flows, speed and electromagnetic torque for the different normal models.

These simulations are confirmed, the defined method in this paper is more careful than other methods.

Another note is speed simulation. Due to fast and slow modes is decoupled, the necessary simulation time less than other methods. In Table II simulation speed for all of methods is compared.

TABLE I

EIGEN VALUES ASSOCIATED WITH STATOR WINDING, FIRST AND SECOND ROTOR WINDING

Variable Associated with Eigen values	Full order	Fifth order order (integral manifold)	Fifth order order (singular perturbation)
Speed	-6.912	-6.951	-7.18
Stator winding flux linkage	-12.94+j311.74 -12.94-j311.74	-11.34+j312.54 -11.34-j312.54	-10+j313.76 -10-j313.76
First winding flux linkage	-6.62+j5.84 -6.62-j5.84	-6.52+j5.98 -6.52-j5.98	-6.412+j6.01 -6.412-j6.01
Second winding flux linkage	-317.1+j0.902 -317.1-j0.902	.....	.....

TABLE II  
 SIMULATION SPEED

model	Simulation speed(%)
Full order	100
Quasi steady state	125
Singular perturbation	140
New model	146

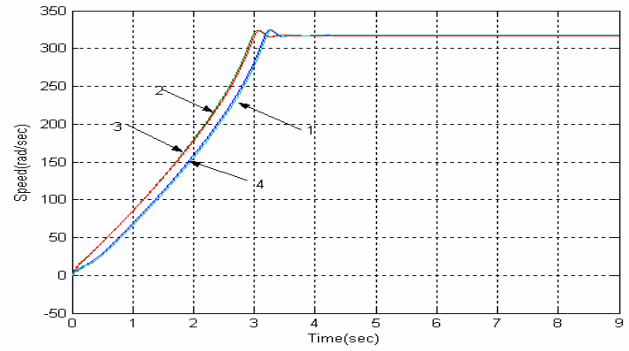

(a) Rotor speed

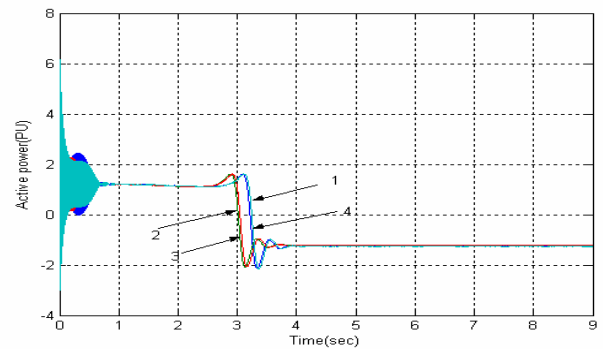

(b) Active power

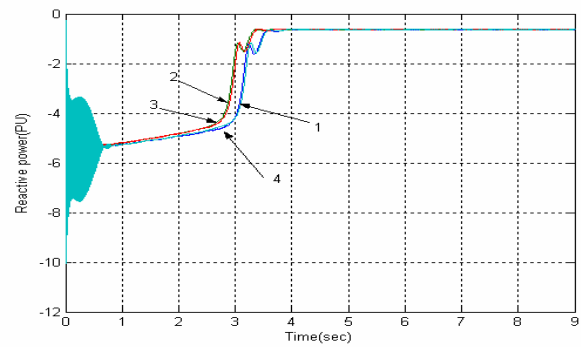

(c) Reactive power

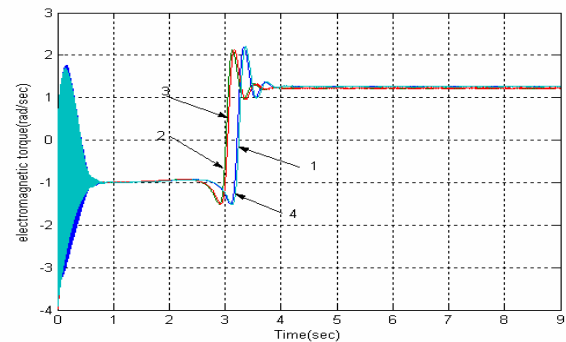

(d) Electromagnetic Torque

Fig. 2 DOIG response at start-up (1) detailed model, (2) quasi steady state model, (3) singular perturbation model, (4) new model

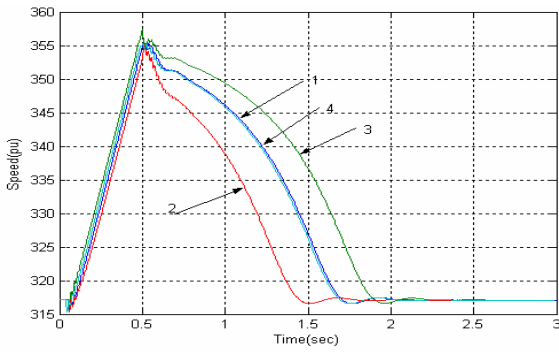

(a) Rotor speed

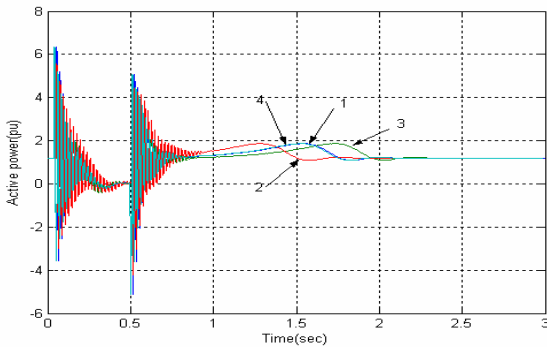

(b) Active power

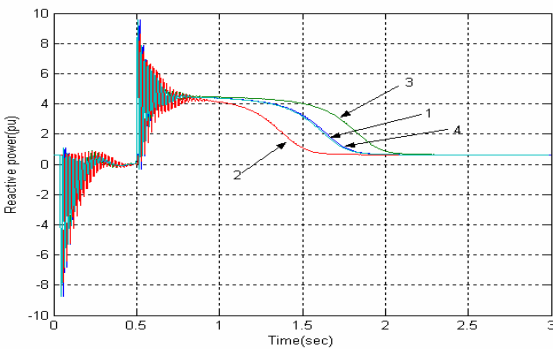

(c) Reactive power

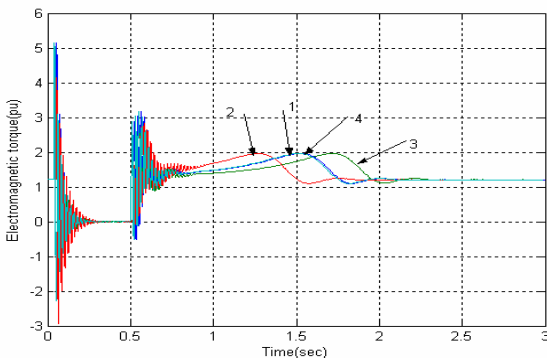

(d) Electromagnetic Torque

Fig. 3 DOIG response to temporary three phase fault (1) detailed model, (2) quasi steady state model, (3) singular perturbation model, (4) new model.

## VIII. CONCLUSION

This paper presents that the decomposed, reduced order model of a DOIG using integral manifold adequately reproduces the original model responses to typical power system voltage conditions. Implementing of the separation procedure through two complete iterations proved to be sufficient to produce results almost identical to those of the original model.

The program used for comparing the computer simulation showed a speed advantage of better than other models for the modified model over the original model.

Furthermore, since the equations for the fast and slow variables are completely decoupled, parallel processing may be used to advantage.

Because of improved computational efficiency, the modified model may be used in studies where machine stator and network transients must be included but where long term behavior is also of interest.

## REFERENCES

- [1] J. B. Ekanayake, L. Holdsworth, X. Wu, N. Jenkins, "Dynamic Modeling of Doubly Fed Induction Generator Wind Turbines", IEEE Trans. On power systems, Vol. 18, No. 2, May 2003, pp.803-809.
- [2] N. Gunarathnam, D. W. Novotny, "The effect of neglecting stator transients of induction machines in dynamic stability studies", IEEE T-PAS-99 PP.2050-2059, Nov 1980.
- [3] E. Levil, D. Rauski, "Self excitation modeling in deep bar and double cage induction generators", IEEE Sixth International Conference on Electrical Machines and Drives, 1993, 8-10 Sep., 1993.
- [4] Castro, R.M.G.; Ferreira de Jesus, J.M.; "A wind park reduced-order model using singular perturbations theory," IEEE Transactions on Energy Conversion, Volume: 11, No:4, Dec.1996, Page(s): 735 -741.
- [5] G. Richrds, O.T. Tan, "Decomposed, reduced order model for double cage induction machines", IEEE T-EC-1, No.3, Sept. 1986, pp.87-93.
- [6] Tseng, H.C.; Kokotovic, P.V.; "Tracking and disturbance rejection in nonlinear systems: the integral manifold approach", Proceedings of the 27th IEEE Conference on Decision and Control, 1988, 7-9 Dec. 1988, Page(s):459-463, vol.1.
- [7] Sedighzadeh. M., Kalantar, M; "A wind farm reduced order model using Integral manifold theory," IASTED conf. Modeling, identification and control (MIC 2004), 23-25 Feb 2004, Switzerland, PP.281-286.