

Locating Critical Failure Surface in Rock Slope Stability with Hybrid Model Based on Artificial Immune System and Cellular Learning Automata (CLA-AIS)

Ramin Javadzadeh and Emad Javadzadeh

Abstract—Locating the critical slip surface with the minimum factor of safety for a rock slope is a difficult problem. In recent years, some modern global optimization methods have been developed with success in treating various types of problems, but very few of such methods have been applied to rock mechanical problems. In this paper, use of hybrid model based on artificial immune system and cellular learning automata is proposed. The results show that the algorithm is an effective and efficient optimization method with a high level of confidence rate.

Keywords—CLA-AIS, Failure surface, optimization methods, Rock slope

I. INTRODUCTION

THE rock slope stability analysis has been extensively studied in the last two decades. Many methods for analysis slope have been developed. The common analytical methods include Bishop's simplified method[1], Morgenstern and Price's method[2], Spencer's method[3], the General Limit Equilibrium method[4] and the generalized Wedge method[5]. Many new approaches based on intelligence and machine learning have been developed to automate search in critical slop surface such as fuzzy logic[6] artificial neural network[7] genetic algorithm[8] and particle swarm optimization[9-11].

In this paper, Hybrid models based on artificial immune system and cellular learning automata(CLA-AIS)[12] and Bishop's simplified method are applied to locate the critical slip surface with the minimum factor of safety for a jointed rock mass slope stability.

The paper is divided as follows. The second section presents the Hybrid models based on artificial immune system and cellular learning automata(CLA-AIS). Rock slope stability method is introduced in the third section. Experimental results are reported in Section 4 and the paper is ended with conclusions in Section 5.

II. HYBRID MODELS BASED ON ARTIFICIAL IMMUNE SYSTEM AND CELLULAR LEARNING AUTOMATA(CLA-AIS)

In the CLA-AIS model the population of antibodies is conformed to a cellular grid and within each CA cell there are learning automata equal to the number of variables forming antibody (problem space dimension) and antibody value is determined according to the learning automata[12].

To this end, it is assumed that each cell in the cellular grid of CLA has two components, in this model: antibody and antibody model. Antibodies are the middle solutions to the specified problem. Antibody model is comprised of some learning automata that learn how to assign antibody values in order to achieve global optimum based on their own and the other genomes experiences. As a result, the evolution process improves the antibody value according to the evaluation function. The learning automata is assigned to antibodies in a way that every antibody variable has one learning automaton assigned to. [12].

Cellular learning automaton $CLA(L_1, \dots, L_k)$ with k cells in which each cell has some learning automata is studied. In each cell, there is one string in real domain that represents the state of that cell. The string is the antibody in the algorithm. assuming that CLA is synchronous, in time t every cell, i , investigates its own and its neighbors antibody and selects some of them to be appropriate neighbors according to the evaluation function. Each cell develops a reinforcement signal vector for its learning automata according to its selected neighbors. Then, learning algorithm updates the probability of each action of learning automata to improve antibodies in terms of reaching global optimum. According to artificial immune system and learning automata algorithms, every antibody establishes clone based on the values provided by

learning automata. Afterwards, X_{t+1}^i best antibody of the clone is selected to produce the new antibody. Figure 1 illustrates a CLA-AIS model[12].

Ramin Javadzadeh., Bojnourd Branch, Islamic Azad University-Bojnourd, Iran (Email: javadzadeh.r@srbiau.ac).

Emad Javadzadeh., Bojnourd Branch, Islamic Azad University-Bojnourd, Iran (Email: emadpce@gmail.com).

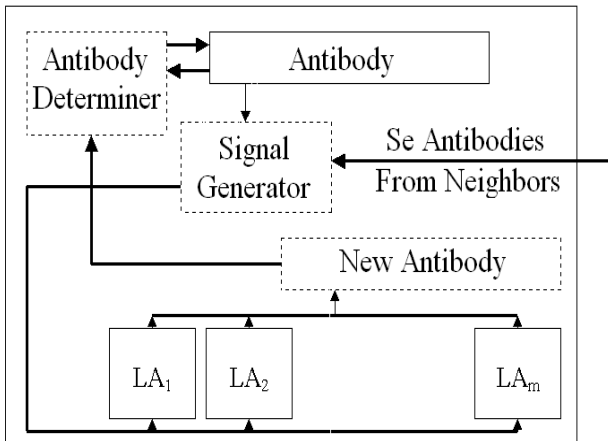

Fig. 1 A CLA-AIS model

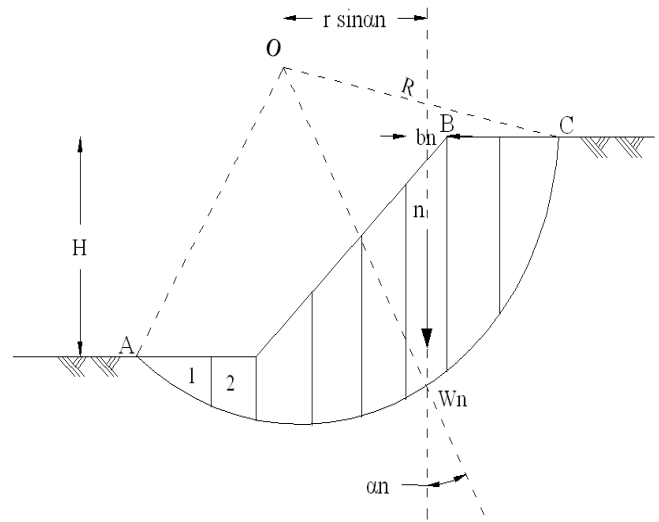

Fig. 2 Circular slip surface

III. THE SIMPLIFIED BISHOP METHOD

Bishop developed the Simplified Bishop Method. This procedure is based on the assumption that the interslice forces are horizontal, as shown in Figure 2 and 3 circular slip surfaces is also assumed in the Simplified Bishop Method. Forces are summed in the vertical direction [13]. The resulting equilibrium equation is combined with the Mohr-Coulomb equation and the definition of the factor of safety to determine the forces on the basis of the slice. Finally, moments are summed about the center of the circular slip surface to obtain the following expression for the factor of safety.

$$F_s = \frac{\sum_{n=1}^{n=p} (cb_n + W_n \tan \phi + \Delta T \cdot \tan \phi) \cdot \frac{1}{m_{\alpha(n)}}}{\sum_{n=1}^{n=p} W_n \sin \alpha_n} \quad (1)$$

where Δx is the width of the slice, and m_{α} is defined by the following equation,

$$m_{\alpha(n)} = \cos \alpha_n + \frac{\tan \phi \cdot \sin \alpha_n}{F_s} \quad (2)$$

The terms W , c , ϕ , u , P , M_p , and R are defined as earlier for the OMS. Factors of safety calculated from Equation 2 satisfy equilibrium of forces in the vertical direction and overall equilibrium of moments about the center of a circle. Because the value of the term m_{α} depends on the factor of safety, the factor of safety appears on both sides of equation 2. Equation 2 cannot be manipulated such that an explicit expression is obtained for the factor of safety m_{α} . Thus, an iterative, trial and error procedure used to solve the factor of safety as well as illustrated in figure.3 in order to calculate m_{α} .

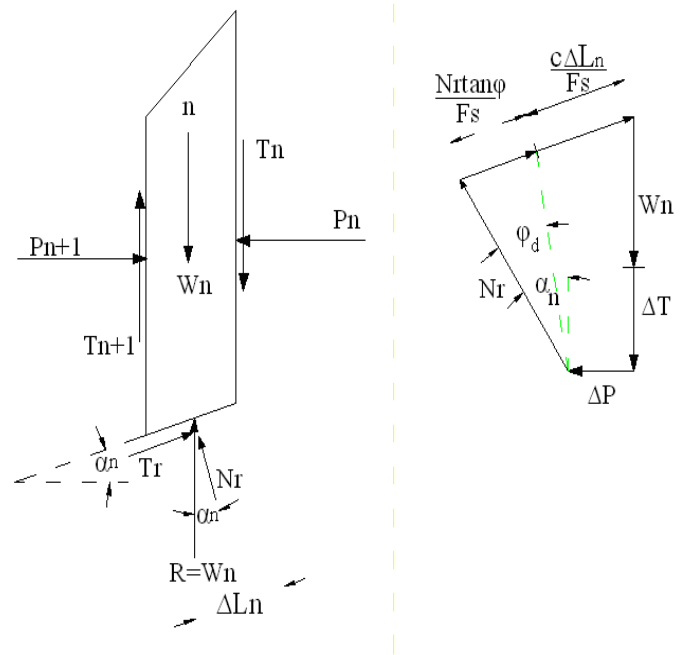

Fig. 3 Typical slice and forces for Simplified Bishop Method

The Simplified Bishop Method does not satisfy limitations horizontal equilibrium of forces. Because horizontal force equilibrium is not completely satisfied, the suitability of the Simplified Bishop Method for pseudo-static earthquake analyses is under question due to an additional horizontal force is applied. The method is also restricted to analysis with circular shear surfaces [13]. It has been shown by a number of investigators (Whitman and Bailey 1967; Fredlund and Krahn 1977) that the factors of safety calculated by the Simplified Bishop Method is comparable well with factors of safety which is calculated using rigorous methods, usually within 5 percent. Furthermore, the procedure is relatively simple compared to more rigorous solutions, computer executes solutions rapidly, and hand calculations are not very

time-consuming. The method is widely used all over the world, and thus, a good record of experience with the method exists. The Simplified Bishop Method is an acceptable method for calculating factor of safety for circular slip surfaces. It is recommended that, the Simplified Bishop Method is used where major structures are designed. The final design should be checked using Spencer's Method.

steeper slope of 75° in likewise homogeneous rock is discussed [14].

The first example for rock data is taken from Hammah et al [15]. The geometry of the slope and the meshing used in the FE calculation is shown in Fig. 6. Material data are given in Table 1. The stress domain for fitting is set to $s_3 \text{ max} = 237$ kPa following the recommendation by Hoek et al. [16].

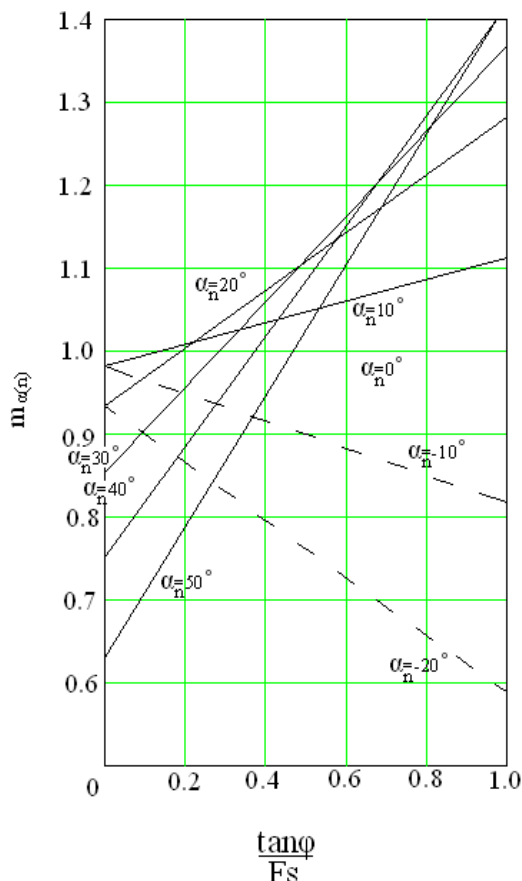

Fig. 4 calculation of m_α

Verification procedures: When the Simplified Bishop Method is used for computer calculations, results can be verified by hand calculations using a calculator or a spreadsheet program, or using slope stability charts. An approximate assessment of calculations can also be performed using the Ordinary Method of Slices, although the OMS will usually give a lower value for the factor of safety, especially if ϕ is greater than zero and pore pressures are high [13].

IV. EXPERIMENTAL RESULT

The merits of the proposed extensions compared to the HB failure criterion can be best illustrated in slope failure examples. Results from the HB and the HBMN criteria with intrinsic material strength reduction are compared to results from analyses that employ equivalent MC criteria. The chosen examples are simple, excluding soil layering, ground water flow, etc. First, a relatively flat slope (35.5°) in a homogeneous weathered rock layer is investigated. Second, a

TABLE I

MATERIAL PARAMETERS USED IN THE SLOPE FAILURE ANALSES

slope	W (MN/m ³)	σ_{ci} (MPa)	m_i	GSI	D	ϕ (°)	C(kPa)
35.5°	0.025	30	2.0	5	0.0	21	20
75.0°	0.026	40	10.0	45	0.9	38	180

All plane strain analyses were performed with the FE code Plaxis V8 using six noded triangular elements. The applied load stepping scheme relies on an arc-length method. Specifically, slope stability was determined for the HB, the mixed HBMN, and the MC failure criteria. For the latter the commercially available phi-c reduction procedure within Plaxis V8 was applied. The factors of safety for the HB and the mixed HBMN were derived by varying the material strength reduction factor g in steps of 0.01 and subsequently applying gravity load to the slope. The highest factor that leads to a convergent solution is considered the ultimate strength reduction factor, or the factor of safety. The equivalent MC parameters were additionally applied in a Bishop slope stability calculation. The Bishop analysis reproduced the results of the j-c reduction scheme reasonably well. Differences to results from the j-c reduction scheme were found to be well below 2%.

Results of the FE slope analysis are shown in Fig. 5. The geometrical shapes of localized shear strains are almost identical in all analyses. At the same time they are also in reasonably good agreement with the circular failure surface assumed in the simplified Bishop analysis. The material strength reduction factors at which failure occurs are however not in close agreement (Table 2). A detailed discussion of the results follows the next example, which is a steeper slope of 75.0°. Calculation procedures are the same as outlined above. The geometry is given in Fig. 6, material parameters are shown in Table 2. Both, geometry and material parameters are selected in close agreement to an example presented in Wyllie and Mah [17]. The results from the steeper slope calculation are illustrated in Fig. 9 and quantified in Table III. The results from the hybrid method base on CLA-AIS and Bishop method for example one is illustrated in Fig. 10 and for example two is illustrated in Fig. 11 and quantified in Table 3.

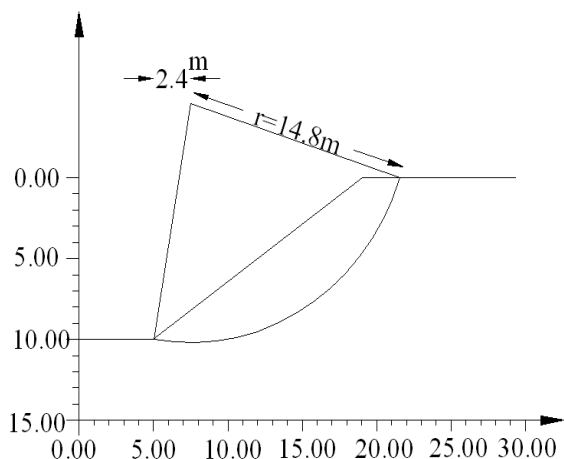

Fig. 5 results from the hybrid method base on CLA-AIS and Bishop method for example one

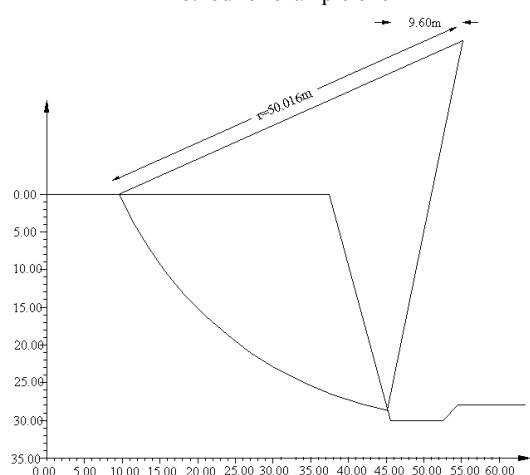

Fig. 6 results from the hybrid method base on CLA-AIS and Bishop method for example two

V. DISCUSSION OF RESULTS

In both slope examples, the factorized HB calculation gives the least slope stability. When the influence of the intermediate principal stress on failure (HBMN) is included, the factor of safety increases. In the example one, the analysis with equivalent MC parameters that was determined by the procedure outlined in [18] gives higher slope stabilities than the HB analysis. Especially, in the steep slope example, the differences are significant.

TABLE II
 SLOPE FAILURE ANALYSES RESULTS

slope	Bishop	MC	HB	HBMN	Hybrid method
35.5°	1.37	1.37	1.51	1.72	1.3756
75.0°	1.55	1.54	1.00	1.02	1.60

The geometrical shapes of localized shear strains are almost identical in the different analyses of the flat slope. In the analysis of the steep slope, the localized shear strains in the HB and HBMN differ notably from those observed in the equivalent hybrid method based on CLA-AIS and Bishop method calculation. As the friction angle in the latter is

generally underestimated in the apex region, it is reasonable to obtain somewhat steeper bands of localized shear strains in the factorized HB and HBMN calculations.

Finally, the following conclusions can be drawn from the examples presented: (a) an equivalent hybrid method based on CLA-AIS and Bishop Method calculation can suggest higher slope stabilities than the HB criterion, it is derived for. Ambiguities in deriving equivalent hybrid method based on CLA-AIS and Bishop Method parameters can be avoided when the HB criterion is factorized directly. (b) The intermediate principal stress influence on material strength indicates higher slope stabilities. The use of the mixed HBMN criterion can save the time to produce the design.

REFERENCES

- [1] A.W. Bishop, "The use of the slip circle in the stability analysis of slopes". *Geotechnique*, 1955 vol.5, pp.7-17.
- [2] N. R. Morgenstem and V. E. Price, "The analysis of stability of general slip surface". *Geotechnique*, 1965 vol.15, pp.79-93.
- [3] E. Spencer, "A method of analysis of the stability of embankments assuming parallel interslice force". *Geotechnique*, 1967 vol.17, pp.11-26
- [4] D. G. Fredland, and J. Krahn, "Comparison of slope stability method of analysis", *Con . Geot. J.*, 1977, vol.14, pp.429-439.
- [5] , I. B. Donald and P. S. K. Giam, "a. Improved comprehensive limit equilibrium stability analysis", *Dept. of Civil Engrg, Report No .1/1989*, Monash University, Melbourne, Australia.
- [6] H. Bandemer. and S. Gottwald ,. "Fuzzy set, fuzzy logic, fuzzy methods with applications", 1994, wiley & sons, Ltd
- [7] M. T Hagan , H. B. Demuth and M. Beale, "Neural Network Desig"n, PWS Publishing Company.
- [8] Z. Michalewicz, "Genetic Algorithms + Data Structures = Evolution Programs", 1996 *Springer-Verlag*, Berlin.
- [9] A. P. Engelbercht. "Computational Intelligence An Introduction", 2007, *Second Edition*, John Wiley & sons, Ltd
- [10] ,I. C. Trelea, "The particle swarm optimization algorithm, *Convergence analysis and parameter selection*", 2003, *Information Processing*, vol.6, pp. 317-325.