

# Generalized Noise Analysis of Log Domain Static Translinear Circuits

E. Farshidi

## II. BASIC PRINCIPLE

### A. Log Domain Translinear Circuits

In general, the main scenario of a log domain circuit is that its signals are externally linear in current domain, but internally compressed and nonlinear in voltage domain. Transistors are good choice for log domain because the I-V relationship of bipolar transistors and MOS transistors in weak inversion region is defined as

$$I = I_S e^{\frac{V}{U_T}} \quad (1)$$

where  $I_S$  is a specific current parameter of the semiconductor device,  $U_T$  is thermal potential,  $I$  is the collector current of bipolar, or drain current of MOS transistor and  $V$  is the base-emitter voltage of bipolar or gate-source voltage of MOS transistor

The main Kirchoff's voltage law (KVL) equation of  $N$  series voltages  $v_1, v_2, \dots, v_n$  of the base-emitter voltages of bipolar [1] or the gate-source voltages of MOS transistors [7] in a translinear loop, as shown in figure1, can be expressed as:

$$\sum_{k=1}^N \pm V_k = 0. \quad (2)$$

To write above equation in terms of sum of logs, (1) is substituted into (2) that yields

$$\sum_{k=1}^N \pm \ln(I_k) = 0 \quad (3)$$

Assuming that  $w_{out}$  is the number of output current repeats and  $w_k$  is the number of current  $I_k$  repeats in translinear loop, and with the aim of solving (3) for the output current  $I_{out}$ , the equation can be rearranged as

$$w_{out} \ln(I_{out}) = \sum_{k=1}^N \mp w_k \ln(I_k). \quad (4)$$

Then the final translinear equation in the absence of noise sources is given by

$$I_{out}|_{NL} = \prod_{k=1}^N I_k^{\mp \frac{w_k}{w_{out}}} \quad (5)$$

where  $I_{out}|_{NL}$  denotes the noiseless output current.

**Abstract**—This paper presents a new general technique for analysis of noise in static log-domain translinear circuits. It is demonstrated that employing this technique, leads to a general, simple and routine method of the noise analysis. The circuit has been simulated by HSPICE. The simulation results are seen to conform to the theoretical analysis and shows benefits of the proposed circuit.

**Keywords**—Noise analysis, log-domain, static, dynamic, translinear loop, companding.

## I. INTRODUCTION

THE continuing trend toward low voltage/power circuits has increased the interest of researchers in the applications of log domain [1-3] and other types [4-5] of companding (compressing/ expanding) techniques. In a system employing companding, the dynamic range of a signal is different at various points of the signal path and input-output current relationship is linear, even though the system is internally nonlinear. Thus, the main advantage of these systems is that they offer large dynamic range because of voltage swing reduction at internal nodes. The nonlinear internal nodes lead to an unusual behaviour with respect to the noise. In addition, because of the large signal behaviour of the circuit, the noises are non-stationary. A noise analysis method for static log domain translinear circuits have been reported by Roermund et al. [6]. In this method noise analysis has been done for some special cases of static circuits. In present work a new general noise analysis technique for translinear circuits, in which the noise of each individual transistor can be transferred to the output node, is presented. The paper organized as follows: In section II, the basic principle of operation of log domain translinear circuit and definition of autocorrelation and power spectral density is presented, in section III a new general noise analysis for static translinear circuits is discussed, in section IV the proposed analysis method is applied for three examples, then simulation results are discussed in section V and concluding remarks are provided in section VI.

E. Farshidi is with the department of Electrical Engineering, Shahid Chamran University of Ahvaz, Ahvaz, Iran (e-mail: farshidi@scu.ac.ir).

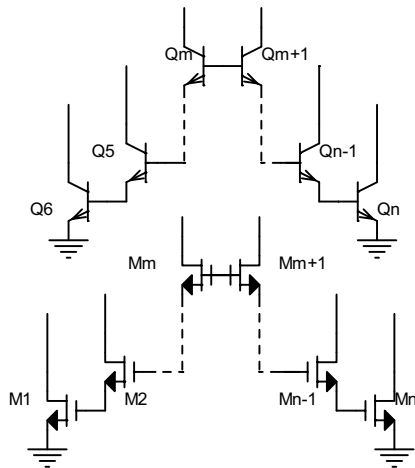

Fig. 1 A BJT translinear loop (up) and a MOS translinear loop (down)

### B. Autocorrelation and Power Spectral Density

In current-mode systems in the presence of noise, the output current  $I_{out}$  can be divided into three components: deterministic component  $C(t)$ , signal component  $SIG(t)$  and a noise component  $T(t)$  defined as [8]:

$$C(t) = E[I_{out}]_{\vec{s}, \vec{n}} \quad (6)$$

$$SIG(t) = E[I_{out}] - C(t) \quad (7)$$

$$T(t) = I_{out}(t) - SIG(t) - C(t) \quad (8)$$

where  $\vec{s}$  denotes the vector of input signals,  $\vec{n}$  the vector of noise sources and  $E[\cdot]$  the mathematical expectation. Also the autocorrelation  $R(\tau, t)$  of signal  $X(t)$  is defined as

$$R_T(\tau, t) = E[X(\tau)X(t+\tau)] \quad (9)$$

and the time dependent frequency spectrum of generalized non-stationary signals  $S(\omega, t)$  is obtained by calculating the Fourier transform of an autocorrelation function  $R(\tau, t)$  with respect to the variable  $\tau$  as follows[9]

$$S(\omega, t) = \int_{-\infty}^{+\infty} R(\tau, t) e^{-j\omega\tau} d\tau \quad (10)$$

Since signals  $C(t)$ ,  $SIG(t)$  and  $T(t)$  are completely uncorrelated the autocorrelation functions  $R_C(\tau, t)$ ,  $R_{SIG}(\tau, t)$  and  $R_T(\tau, t)$ , and power spectral density functions  $S_C(\omega, t)$ ,  $S_{SIG}(\omega, t)$  and  $S_T(\omega, t)$  can be calculated directly.

The dominant noise source of the bipolar or weak inversion MOS transistor, is shot noise, that its autocorrelation is given by

$$R_{i_n}(\tau, t) = qI(t)\delta(t) \quad (11)$$

where  $q$  is the unity charge,  $i_n$  is the current noise source and  $I(t)$  is the collector or drain current.

Using (10) the double-sided power spectral density function of shot noise is given by [9]

$$S_{i_n}(\omega, t) = qI_c \quad (12)$$

In non-stationary noises, each separate noise term in  $T(t)$ , denoted by  $T_k(t)$ , consists of a noise current source  $i_{n,k}(t)$  multiplied by a noise free time dependent factor  $G_k(t)$ , where all these separate noise sources are uncorrelated. Thus, using (9), (10) and (11) the power spectral density of  $T_k(t)$  becomes [9]

$$S_{T_k}(\omega, t) = qI_k G_k^2 \quad (13)$$

The signal to noise ration (SNR) can be obtained by time averaging of  $S_{SIG}(\omega, t)$  and  $S_T(\omega, t)$ , followed by a division.

### III. ANALYSIS OF NOISE OF STATIC TRANSLINEAR CIRCUITS

Shot noise represented by current source can be easily incorporated in the translinear loop equation. Figure 1 shows a BJT and a MOS transistor that are biased with collector and drain current  $I(t)$  and accompanied by a shot noise source  $i_n(t)$ .

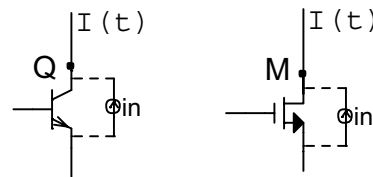

Fig. 2 BJT and MOS transistors, in presence of noise

In the presence of the noise, (4) can be rewritten as

$$w_{out} \ln(I_{out} + i_{n,out}) = \sum_{k=1}^{\mp} w_k \ln(I_k + i_{n,k}) \quad (14)$$

Since current noise in each transistor is much smaller than its current bias ( $i_k(t) \ll I_k$ ) applying first-order Taylor approximation for each term of right hand side results

$$\ln(I_{out} + i_{n,out}) \cong \ln(I_k) + \frac{i_{n,k}}{I_k} \quad (15)$$

Substituting (15) into (13) gives

$$w_{out} \ln(I_{out} + i_{n,out}) = \sum_{k=1}^{\mp} w_k \left[ \ln(I_k) + \frac{i_{n,k}}{I_k} \right] \quad (16)$$

Assuming that

$$\sum_{k=1}^{\mp} \frac{i_{n,k}}{I_k} \ll \sum_{k=1}^{\mp} \ln(I_k) \quad (17)$$

and solving (16) for  $I_{out}$ , then using first-order Taylor approximation as  $e^{X+dx} \cong e^X(1+dx)$  results

$$I_{out} = \prod_{k=1}^n I_k^{\frac{w_k}{w_{out}}} \left( 1 \mp \frac{1}{w_{out}} \sum_{k=1}^n \frac{w_k i_{n,k}}{I_k} \right) - i_{n,out} \quad (18)$$

Rearranging and substituting (5) into (18) gives

$$I_{out} = I_{out|NL} + \frac{I_{out|NL}}{w_{out}} \left( \mp \sum_{k=1}^n w_k \times \frac{i_{n,k}}{I_k} - w_{out} \times \frac{i_{n,out}}{I_{out|NL}} \right) \quad (19)$$

The first term of the right hand side of the equation indicates the noiseless output current and second term indicates equivalent output noise component that can be represented, respectively by (20) and (21):

$$S(t) + C(t) = I_{out|NL} \quad (20)$$

$$T(t) = \frac{I_{out|NL}}{w_{out}} \left( \mp \sum_{k=1}^n w_k \times \frac{i_{n,k}}{I_k} - w_{out} \times \frac{i_{n,out}}{I_{out|NL}} \right) \quad (21)$$

To obtain some intuition about (21), it can be noticed that:

- A) In case of  $w_{out} = w_k = 1$ , the noise current source  $i_k$  of each transistor in translinear loop with bias current  $I_k$  can be transferred to the output by division of noise source to the bias current of that transistor and multiplication of the result by the noiseless output current.
- B) With the existence of repeated output current  $w_{out}$ , the transferred noise will be divided by this factor.
- C) The total transferred noise of  $w_k$  transistors with bias current  $I_k$  is  $w_k$  times of each single transistor.

The main advantage of (21) is that, in spite of the fact that translinear circuits are internally nonlinear, it offers a general equivalent output referred noise for all transistors noises. It should be pointed out that this method covers the results of especial cases given in [6].

All terms of (21) are mutually independent, therefore the autocorrelation of T(t) is given by

$$R_T(\tau, t) = \sum_{k=1}^n \frac{w_k}{(w_{out})^2} \times \frac{I_{out|NL}^2 R_{i_{n,k}}(\tau, t)}{I_k^2} + \frac{1}{w_{out}} \times R_{i_{n,out}}(\tau, t) \quad (22)$$

and power spectral density of T(t) is expressed as

$$S_T(\omega, t) = \left( \sum_{k=1}^n \frac{q w_k}{w_{out}^2} \times \frac{(I_{out|NL})^2}{I_k} \right) + \frac{q}{w_{out}} I_{out|NL} \quad (23)$$

#### IV. EXAMPLES

This section applies the proposed noise analysis method for three circuits containing static translinear loop.

##### A. Square Circuit

Considering the square circuit of figure 3[6], that contains a translinear loop, and using (5), the output-input relationship in the absence of noise is given by

$$I_{out|NL} = \frac{(I_{in})^2}{I_b} \quad (24)$$

where  $I_{out|NL}$ ,  $I_{in}$  and  $I_b$  are noiseless output current, input current and bias current, respectively.

Applying (20) and (21) to this circuit gives

$$S(t) + C(t) = I_{out|NL} = \frac{(I_{in})^2}{I_b} \quad (25)$$

$$T(t) = I_{out|NL} \left( \frac{2i_{n,1}}{I_{in}} - \frac{i_{n,3}}{I_b} - \frac{i_{n,4}}{I_{out|NL}} \right) \rightarrow T(t) = \frac{2I_{in}i_{n,1}}{I_b} - \frac{(I_{in})^2 i_{n,3}}{I_b^2} - i_{n,4} \quad (26)$$

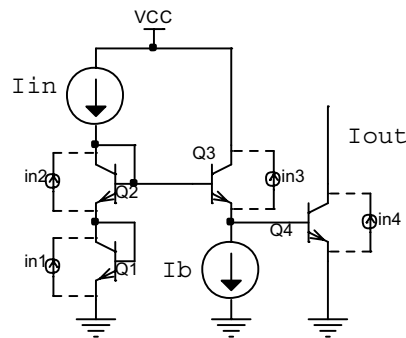

Fig.3 The square circuit in presence of current noise sources

Using (23) the power spectral density of the total output noise  $T(t)$  is found to be

$$S_T(\omega, t) = q \frac{(I_{in})^4}{I_b^2} \left[ \frac{2}{I_{in}} + \frac{1}{I_b} \right] + q \frac{(I_{in})^2}{I_b} \rightarrow S_T(\omega, t) = q \left[ \frac{2(I_{in})^3}{I_b^2} + \frac{(I_{in})^4}{I_b^3} \right] + \frac{q(I_{in})^2}{I_b} \quad (27)$$

It should be pointed out that these results are the same as reported in [6].

##### B. A MOS Translinear Circuit

In this section the proposed method is applied for the sample MOS translinear circuit of figure 4. In this circuit by having MOS transistors in weak inversion region, the analysis of the circuit shows that the following relation exists between the input and output currents:

$$I_{out|NL}^2 = \frac{(I_{in})^3}{I_b} \quad (32)$$

Using (21), the total output noise is obtained by

$$T(t) = \frac{I_{out|NL}}{2} \left( \frac{3i_{n,1}}{I_{in}} - \frac{i_{n,2}}{I_b} - \frac{2i_{n,4}}{I_{out|NL}} \right) \quad (33)$$

Substituting (32) into (33) gives

$$T(t) = \frac{(I_{in})^3}{2I_b} \left( \frac{3i_{n,1}}{I_{in}} - \frac{i_{n,2}}{I_b} - \frac{2i_{n,4}}{I_{out|NL}} \right) \quad (34)$$

And applying (23) the power spectral density is given by

$$S_T(\omega, t) = \frac{q}{4} \frac{(I_{in})^3}{I_b} \left[ \frac{3}{I_{in}} + \frac{1}{I_b} \right] + \frac{q}{2} \left[ \frac{(I_{in})^3}{I_b} \right]^{\frac{1}{2}} \rightarrow$$

$$S_T(\omega, t) = \frac{q}{4} \left[ \frac{3I_{in}^2}{I_b} + \frac{I_{in}^3}{I_b^2} + \frac{2I_{in}^2}{I_b^{\frac{3}{2}}} \right] \quad (35)$$

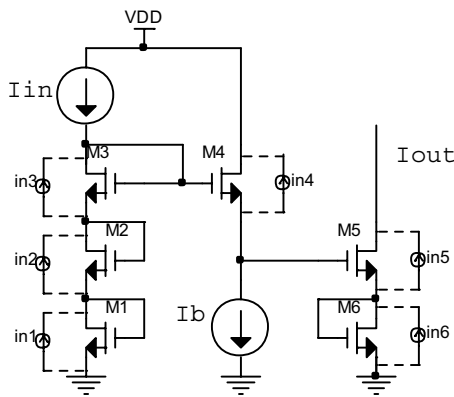

Fig. 4 A MOS translinear circuit in presence of current noise sources

### V. SIMULATION RESULTS

Simulation of translinear circuit of figure 4 was performed using HSPICE with 0.6um AMS CMOS process parameters. MOS transistors were biased in weak inversion and the aspect ratio of the NMOS and PMOS transistors were 50um/10um and 100um/10um, respectively. Stationary current noises  $i_{n1}$ ,  $i_{n2}$  and  $i_{n3}$  were injected at different frequency and amplitudes and for clarity the effect of the other transistors noise sources was assumed to be zero ( $i_{n4} = i_{n5} = i_{n6} = 0$ ).  $V_{dd}=2.5V$ ,  $I_{in}=200nA$  and  $I_b=100nA$  were employed. Using (32) the noiseless output current with above assumption is obtained as

$$I_{out|NL}^2 = \frac{(200nA)^3}{100nA} \rightarrow I_{out|NL} \approx 282.84nA \quad (36)$$

Applying (33) the equivalent output current noise  $T(t)$  yields:

$$T(t) = \frac{I_{out|NL}}{2} \left( \frac{3i_{n1}}{I_{in}} \right) \rightarrow$$

$$T(t) \approx \frac{282.84}{2} \left( \frac{3i_{n1}}{200} \right) = 2.12i_{n1} \quad (37)$$

The simulation results together with the calculated results of (37) are shown in figure 5. The figure demonstrates the validity of the proposed noise analysis.

### VI. CONCLUSION

A general method for the noise analysis of the static translinear loop circuits has been presented, that leads to representation of the power spectral density of the equivalent output noise. The only assumption made is that the noise is

“small,” the assumption that is valid for practical circuits.

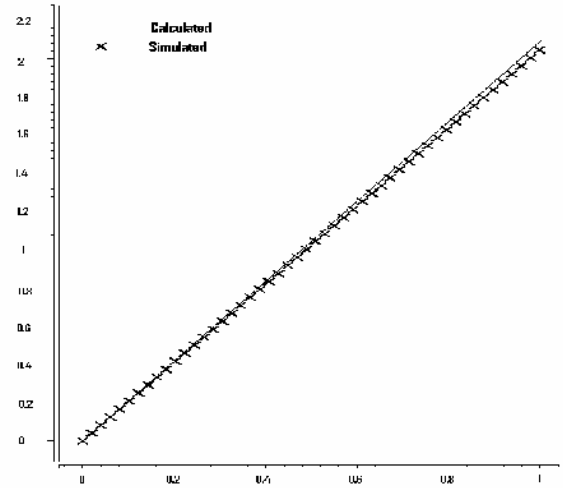

Fig. 5 Simulated and calculated noise transfer function

### REFERENCES

- [1] B. Gilbert, “Translinear circuits: A proposed classification,” *Electron.Lett.*, vol. 11, no. 1, pp. 14-16, 1975.
- [2] D. R. Frey, “Exponential state space filters: A generic current mode design strategy,” *IEEE Trans. Circuits Syst. I*, vol. 43, pp. 34-42, Jan.1996.
- [3] R. W. Adams, “filtering in the log domain,” presented at the 63<sup>rd</sup> Audio Eng. Soc. Conf., New York, NY, preprint q1470, May 1979.
- [4] E. Seevinck and R. J. Wiegierink, “Generalized translinear circuit principle,” *IEEE J.Solid -State Circuits*, vol. 26, no. 8, pp. 1098-1102, aug.1991.
- [5] A. J. Lopez-Martin and A. Carlosena, “Systematic design of companding systems by component substitution,” *Anal. Integr. Circuits Signal Process.*, vol. 28, pp. 91-106, 2001.
- [6] J. Mulder, M. H. L. Kouwenhoven, W. A. Serdijn, A. C. van der Woerd, and A. H. M. van Roermund, “Nonlinear analysis of noise in static and dynamic translinear circuits,” *IEEE Trans. Circuits Syst. II*, vol. 46, pp. 266-277, Mar.1999.
- [7] T. Serrano-Gotarredona, B. Linares-Barranco, and A. G. Andreou, “A General Translinear Principle for Subthreshold MOS Transistors,” *IEEE Trans. On Circuits and Systems-I: fundamental Theory and Applications*, vol.46, no. 5, pp. 607-616, May 1999.
- [8] N. M. Blachman, “The signal-signal, noise-noise, and signal-noise output of a nonlinearity,” *IEEE Trans.InformationTheory*, vol. IT-14, pp. 21-27, Jan.1968.
- [9] J. Mulder, W. A. Serdijn, A. C. van der Woerd, and A. H. M. van Roermund, “Dynamic translinear and log-domain circuits analysis and synthesis,” *Kluwer Academic Publishers*, pp.157-189,1999.