

# Dynamic Fuzzy-Neural Network Controller for Induction Motor Drive

M. Zerikat, M. Bendjebbar and N. Benouzza

**Abstract**— In this paper, a novel approach for robust trajectory tracking of induction motor drive is presented. By combining variable structure systems theory with fuzzy logic concept and neural network techniques, a new algorithm is developed. Fuzzy logic was used for the adaptation of the learning algorithm to improve the robustness of learning and operating of the neural network. The developed control algorithm is robust to parameter variations and external influences. It also assures precise trajectory tracking with the prescribed dynamics. The algorithm was verified by simulation and the results obtained demonstrate the effectiveness of the designed controller of induction motor drives which considered as highly non linear dynamic complex systems and variable characteristics over the operating conditions.

**Keywords**— Induction motor, fuzzy-logic control, neural network control, indirect field oriented control.

## I. INTRODUCTION

In lieu of the advances in power electronics and microprocessors, digitally controlled induction motor drives have become increasingly popular. In many industrial drives advanced digital control strategies for the control of field-oriented induction motor drives with a conventional speed PID controller, have gained the widest acceptance in high performance AC servo systems, if the load changes are small and the operating conditions do not force the system too far away from the linear equilibrium point. However, in certain applications, such as steel mills, paper mills, robotics, machine tools, the drive operates under a wide range of load change characteristics and the system parameters vary substantially. To overcome this drawback, the control algorithm should include a complicated computation process to eliminate the variations in the load disturbance

Manuscript is received October 10, 2005

M. Zerikat is with the Department of Electrical and Computer Engineering, Laboratory of Automatic and Analysis Systems, Higher School of ENSET, Oran –ALGERIA ( phone: +213 41 41 97 16; Fax: +231 41 41 98 06; e-mail: [mokhtar.zerikat@enset-oran.dz](mailto:mokhtar.zerikat@enset-oran.dz))

M. Bendjebbar is with the Department of Electrotechnics, Faculty of Electrical Engineering, University of Sciences and Technology USTOran-ALGERIA (e-mail: [bendjebb\\_dz@yahoo.fr](mailto:bendjebb_dz@yahoo.fr))

N. Benouzza is with the Department of Electrotechnics, Faculty of Electrical Engineering, University of Sciences and Technology USTOran-ALGERIA (e-mail: [benouzza@yahoo.com](mailto:benouzza@yahoo.com))

and systems parameters and also obtain high performance AC system. However, the control algorithms applicable to these systems have become increasingly more complicated, requiring extensive computations for real-time implementation. In recent years, Artificial Neural Network intelligent (ANN) and Fuzzy Logic Controllers (FLC) have gained great important and proved their dexterity of many respects [2,3]. In this field several works have been presented [7,8,9,12,13]. It has great potential using to neural topology does not need the mathematical model of the system to be controlled. In modelling and control of dynamical systems, many different versions of neural network structures are used. Since the late 1990s, several applications using neural networks for the compensation of the non linearity caused by the influence of disturbances, i.e. load or parameter variations were described [1,2,3]. Combination of different artificial intelligent technologies in the control field found interesting and efficient applications [4,6]. In fact, neural network have several attributes that make them an interesting new alternative to control an induction motor: one attribute is their highly parallel structure if networks with a higher number of hidden layers are used. All the neurons in a layer can compute simultaneously to enhance the speed. Another attribute is the simplicity of the required computations performed by each neuron of the network. In this study, Multi-Layer Perceptron (MLP) neural networks using the back-propagation learning rule were used to identify the process model. The control signal is then calculated iteratively according to the responses of a reference model and the identified neural model of the process. A fuzzy logic block is added to improve the overall loop properties. The paper is structured as follows. Section 2 describes a mathematical of induction motor drive; Section 3 gives the structure of the proposed control scheme. The recurrent NN identifier and fuzzy PD control design are discussed in sections 4,5 and 6. Section 7 and 8 provide the simulation results and conclusions, respectively

## II. INDUCTION MOTOR MODEL

Using the Park transformation ( e.g. Vas., 1990), the three-phase stator windings ( $s_A, s_B, s_C$ ) can be transformed into equivalent quadratic-phase windings ( $S_d, S_q$ ). The AC motor dynamic models are described by a set electrical and mechanical non-linear differential equations ( Marino, Peseda and Valigi, 1993).

$$\frac{dw_r}{dt} = \frac{n_p M}{J L_r} (\psi_{rd} i_{sq} + \psi_{rq} i_{sd}) - \frac{T_L}{J} \quad (1)$$

$$\frac{di_{sd}}{dt} = \frac{M R_r}{\sigma L_s L_r^2} \psi_{rd} + \frac{n_p M}{\sigma L_s L_r} w_r \psi_{rd} - \frac{M^2 R_r + L_r^2}{\sigma L_s L_r^2} i_{sd}$$

$$\frac{di_{sq}}{dt} = \frac{M R_r}{\sigma L_s L_r^2} \psi_{rq} - \frac{n_p M}{\sigma L_s L_r} w_r \psi_{rd} - \frac{M^2 R_r + L_r^2}{\sigma L_s L_r^2} i_{sq} + \frac{1}{\sigma L_s} u_{sq} \quad (2)$$

$$\frac{d\psi_{rd}}{dt} = -\frac{R_r}{L_r} \psi_{rd} - n_p w_r \psi_{rq} + \frac{R_r}{L_r} M i_{sd}$$

$$\frac{d\psi_{rq}}{dt} = -\frac{R_r}{L_r} \psi_{rq} + n_p w_r \psi_{rd} + \frac{R_r}{L_r} M i_{sq}$$

$$\sigma = 1 - \frac{M^2}{L_s L_r}$$

where  $i$ ,  $u$ ,  $\psi$  denote current, voltage and flux linkage respectively. Subscripts  $r$  and  $s$  stand for rotor and stator.  $\omega_r$  is the rotor speed,  $d$  and  $q$  denote direct and quadratic components of the vectors with respect to the fixed stator reference frame,  $L$  and  $R$  are the auto-inductances and resistances,  $M$  is the mutual inductance and  $T_L$  is the load torque. In the following, we plan to design an fuzzy-neural controller which should stabilize the system and cause  $y(t)$  to track a bounded reference  $r(t)$  asymptotically. In other words, the aim is to determine the control input  $u(t)$  for all  $t \geq t_0$ , so that  $\lim_{t \rightarrow \infty} \|\omega_r(t) - \omega(t)\| \leq \varepsilon$ , for some specified constant  $\varepsilon \geq 0$

### III. THE PROPOSED CONTROL SCHEME

Figure 1. depicts the bloc diagram of the proposed closed-loop control scheme. The reference input signal is  $\omega_r$ . A Recurrent Neural Network Identifier (RNNI) was used to determine on-line an approximate current non linear model of the unknown motor dynamics. The Recurrent Neural Network controller (RNNC) was used to produce an adaptive control so that the motor speed can accurately track the reference commmde  $w_r$ . The control signal  $u_{net}$  is combined with the output signal  $u_{fuzzy}$  of the Fuzzy-Logic (FLC) to produce the actual plant input signal  $u$ . The widely used back-propagation learning algorithm, in order to automatically the parameters of the RNNI and RNNC. The control goal is that the plant output  $w$ , follows as closely as possible the out signal  $y_m$  of the reference model. The reference model of the plant is an ideal model that has the desired characteristics related to the rise time, overshoot, steady-state error, etc.

### IV. RECURRENT NEURAL NETWORK IDENTIFIER

We constructed a neural network to estimate the unknown

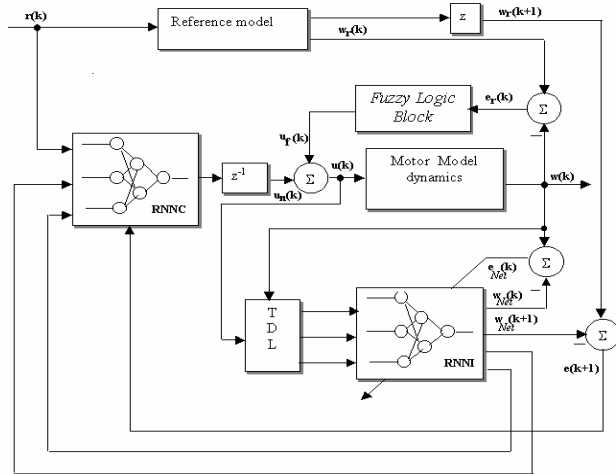

Fig.1 Block diagram representation of the adaptation learning control scheme

parameters to resolve the above difficulty. First, we assumed a plant expressed as:

$$\omega(k) = f(\omega(k-1), \dots, \omega(k-n+1), i_{qs}(k-1), \dots, i_{qs}(k-m)) \quad (4)$$

where  $f$  is an unknown non linear function we want to identify,  $\omega$  and  $i_{qs}$  are the output and input of the plant respectively,  $n$  and  $m$  are the order of the  $\omega$  and  $i_{qs}$ . We now consider the identification of the unknown function  $f$  based on neural network. The network structure of the proposed RNNI is shown in fig.3. Such a neural network contains three layers: input layer; hidden layers and output layer. Each layer is composed of several neurons. The number of the neurons in the input and output layers depends on the number of the selected input and output variables. The numbers of hidden

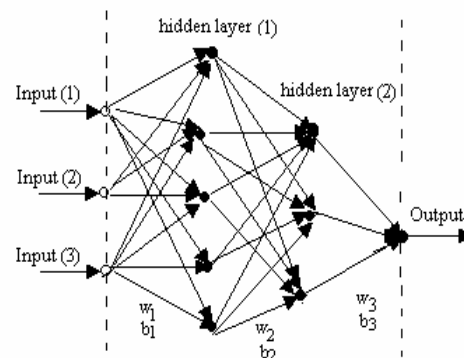

Fig. 3 Architecture of three-layer neural network

layers and the number of neurons in each depend on the system dynamics and the desired degree of accuracy. In Artificial neural network applications, selection of the number of neurons in the input layer is an important aspect. A trial-

and-error basis [5], can be used to select a proper of the hidden neurons. All the neurons in adjacent layers are interconnected. The strength of the interconnected is determined by the weighting vector of the Neural Network (NN). The most common method of NN training is back error propagation algorithm [6]. The algorithm is based on the gradient search-technique that minimizes a cost function of the Mean Squares Errors (MSE). The weights  $w_{ij}$  of the interconnections between two adjacent layers can be updated on the following formula [5,6].

$$w_{ij}(k+1) = w_{ij}(k) + \eta \frac{\partial E}{\partial w_{ij}(k)} \quad (5)$$

where  $\eta$  is a prescribed learning rate and  $k$  is the iteration number, subscripts  $i, j$  indicate the  $i$ -th node in the input layer and the  $j$ -th node in the hidden layer respectively. The cost function  $E$  for training the neural network is defined as:

$$E = \frac{1}{2} \sum_{l=1}^P \sum_{r=1}^K \left( O_r^l - d_r^l \right)^2 \quad (6)$$

where  $O$  neuron output,  $d$  is desired or set-value,  $K$  is number of the neurons in the output layer and  $P$  is the number of the training patterns. In all learning process bipolar sigmoidal activation function has been used. This activation function is non linear and very useful for continuous training scheme. It is defined as:

$$O_j = g(Net_j) = \frac{1}{1 + \exp(-\lambda Net_j)} \quad (7)$$

$\lambda$  is a positive number called as steepness coefficient. This parameter is very important in learning procedure and lies down between one and infinity theoretically.

#### V. RECURRENT NEURAL NETWORK CONTROLLER

The structure of the Neural Network Controller (RNNC) is similar to one of the Neural Network Identifier (RNNI). The objective of RNNC is to develop a back-propagation algorithm such that the output  $\omega(k)$  of the plant can track the reference command  $\omega_r(k)$ . An Integral Proportional (IP) controller is adapted in the speed control loop to calculate the next value of  $u$  using the current iterative value of  $u$ , as well as the current and previous iterative values of the error  $e(k+1)$ . The iterative calculation of the control signal is given by:

$$u(k, t_k) = u(k, t_k) + k_p e(k, t_k) + k_i \sum_{k=0}^t e(k, t_k) \quad (8)$$

Here 
$$e(k, t_k) = \omega_r(k) - \omega_{Net}(k, t_k) \quad (9)$$

Where  $k_p$  and  $k_i$  are the integral-proportional parameters. We need to train ten neural network identifiers to model the Input-Output behaviour of the plant and to iteratively calculate the control value, so as to get a small expected error  $e$ , during each sampling period  $t_k$ . Hence, the tracking problem now, becomes that of adjusting the weights of the RNNC such that:

$$E_c(k) = \frac{1}{2} (\omega_r(k) - \omega_{Net}(k))^2 \quad (10)$$

is minimised.

Using the gradient method, the related weights for the RNNC are calculated. The update rule of weights becomes:

$$V_{ij}(k+1) = V_{ij}(k) + \eta_c \frac{\partial E_c}{\partial V_{ij}(k)} \quad (11)$$

Where  $\eta_c$  is the learning rate of the RNNC.

#### VI. FUZZY PD CONTROLLER DESIGN

The main preference of the fuzzy-logic is that is easy to implement and that it has the ability of generalization. The basic configuration of the fuzzy-logic system is shown in figure 4.

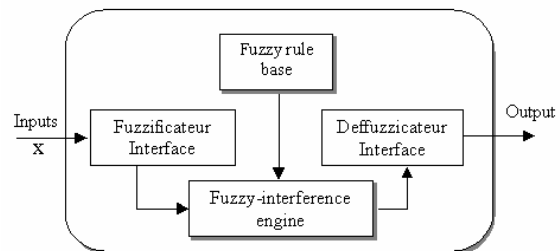

Fig. 4 Basic configuration of the fuzzy logic system

Fuzzy controllers are based on four well known stages. The fuzzification stage takes crisp numerical values and determines their degree of membership in each collection of sets which are given linguistic labels that are meaningful in terms of the problem to be solved. The second part is the fuzzy rule base which expresses relations between the input fuzzy sets  $A$  and  $B$  and the output fuzzy sets  $C$  in the form of: 'IF  $A$  and  $B$  THEN  $C$ '. The fuzzified inputs are combined using these rules in the third part, the fuzzy inference engine. This produces a combined fuzzy output set. The final part, the defuzzifier produces a crisp output from the combined fuzzy output set. Inputs and the output are non-fuzzy values. In this work, a simple Proportional-Derivative (PD) speed control scheme was implemented and used to assess the basic performance of the system. The output of the fuzzy controller  $u_f(k)$  is given by:

$$u_f(k) = F_f(e(k) - ce(k)) \quad (12)$$

Where  $F_f$  is a non linear function determined by fuzzy parameters,  $e(k)$ ,  $ce(k)$  are the error and change-of-error respectively.

A type of those controllers is fuzzy PD controller whose input is the error  $e(k)$ .

$$e(k) = \omega_r(k) - \omega(k) \quad (13)$$

where  $\omega_r(k)$  is the output signal of the reference model and  $\omega(k)$  is the process output at time  $k$ . The control goal is that the plant output signal  $\omega(k)$  follows as closely as possible the output signal  $\omega_r(k)$  of the reference model. The reference model of the plant is an ideal model that has the desired characteristics related to the rise-time, steady-state error. The input-output dynamics of the reference model were assumed to be given by the following second-order model

$$\omega_r(k+1) = a_1 \omega_r(k) + a_2 \omega_r(k-1) + r(k) \quad (14)$$

The constant coefficient in the equation (14) were chosen to guarantee bounded-input bounded-output stability and the steady-state reference track is dictated by the amplitude and functional form of the input  $r(k)$  to the reference model. For the proposed fuzzy controller, the universe of discourse is first partitioned into the five linguistic variables NB, NS, ZE, PS, PB, triangular membership functions are chosen to represent the linguistic variables. Fig. 5 and Fig. 6 show the membership functions and the output of the fuzzy controller is illustrated in Fig. 7

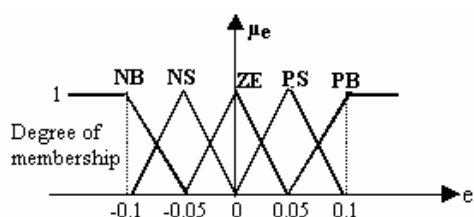

Fig. 5 Membership functions of error

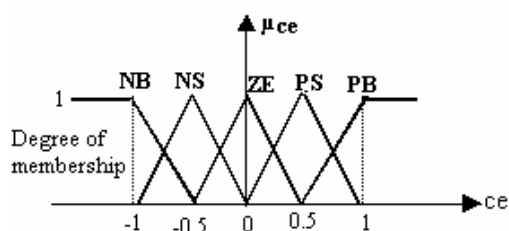

Fig. 6 Membership functions of change in error

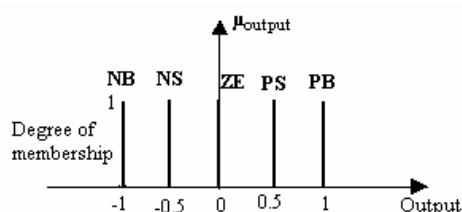

Fig. 7 Membership functions of output signal

TABLE I THE FUZZY CONTROL RULES

$e \setminus ce$	NB	NS	ZE	PS	PB
NB	NB	NB	NS	PB	PS
NS	ZE	NS	ZE	PS	ZE
ZE	PB	PB	ZE	PS	NB
PS	ZE	PS	PB	NS	NB
PB	PB	PS	NS	NS	NB

The labels NB, NS, PB, PS, and ZE denote ‘Negative Big’, ‘Negative Small’, ‘Positive Big’, ‘Positive small’ and Zero, respectively. The max-min inference method was used and the defuzzification was based on the centre of area method.

## VII. SIMULATION RESULTS

The parameters of the induction motor considered in this study are summarized in appendix. The performances of the proposed controllers are evaluated under a variety of operating conditions. The use of both neural network functions with fuzzy compensation yielded satisfying results. The controller algorithm is housed inside the personal computer with Pentium-IV microprocessor and all numerical values of the simulation model are obtained either by measurements or identification from laboratory experiments. The software environment used for these simulation experiments is Matlab Ver. 6.5, with Simulink package and numerical integration is done by the Runge-Kunta 4 algorithm. The reference discrete model with good performance and realisation for a motor speed control system can be chosen as:

$$\omega_r(k+1) = 0.48 \omega_r(k) + 0.25 \omega_r(k-1) + r(k) \quad (15)$$

For all simulations performed in this study, the initial values for the adjustable parameters (weights and biases) of both networks are randomized using the Nguyen-Widrow algorithm [10]. The proportional and derivative parameters of the proposed control scheme are  $k_p=0.52$  and  $k_d=0.01$ . The simulation results are given in fig.8 to fig.12. The plots of these figures show the performances as the combining NN-FLB controller for a variety of step changes in the desired set-point. In the simulations, the learning rate of the recurrent neural network identifier and recurrent neural network controller scheme were set to  $\eta=0.2$  using trial and error to obtain a good speed response. The number of feedward neural network scheme node uses one hidden layer, and the respective number of neurons at the input, hidden, and output layer are  $NN_{2 \times 8 \times 1}$ . Basically, it represents an input-output non linear pattern matching network where the non linearity is introduced by hyperbolic-tan-type transfer function  $\phi(\cdot)$  at the hidden and output layer neurons. An external force of 4 [Nm] is applied to the the induction motor and the speed response is shown in fig. 9. As shown in fig.10, at  $t=0.8s$ , the reference speed is changed from 48 rad/s to 150 rad/s. At  $t=2 s$ , the reference speed is changed from 150 rad/s to 100 rad/s. In the next simulation, the NN-FLB is evaluated under combining trajectory of a square – triangular reference track. One can see from the fig.11 that the results were very successful and the obtained results confirm the validity of the proposed control scheme. In fig.12, one can observe the superior properties of the loop controlled by the NN-FLB control mechanism and the conventional controller such as the proportional, integral and derivative PID.

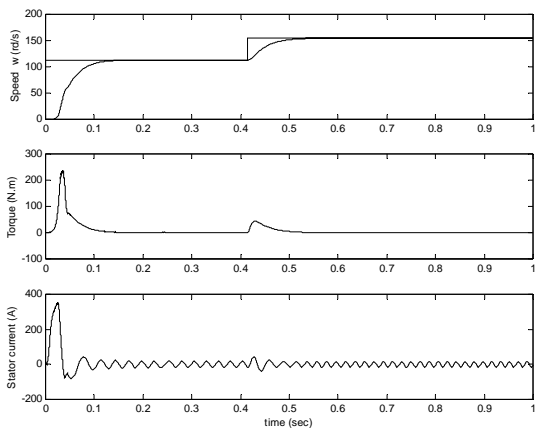

Fig. 8 Speed response under no-load torque

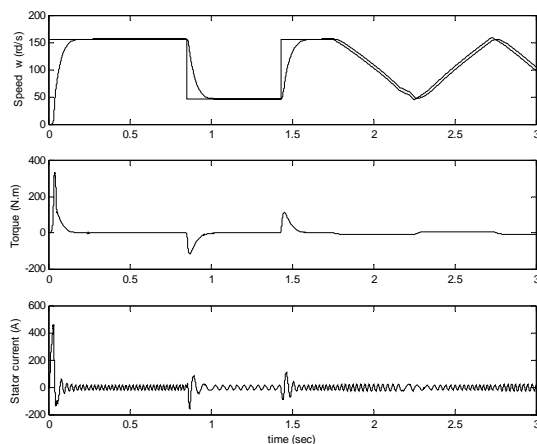

Fig. 11 Speed response of a square - triangular reference track

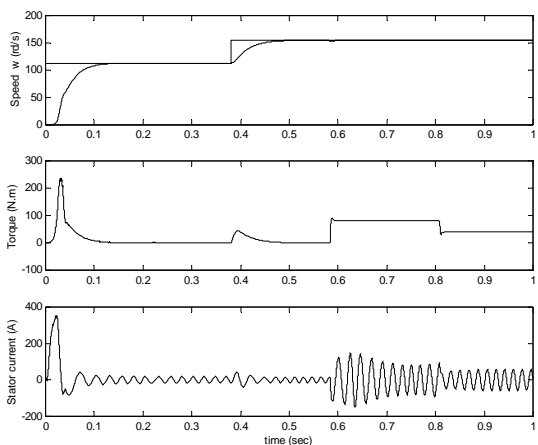

Fig. 9 Speed response with two load torque changes

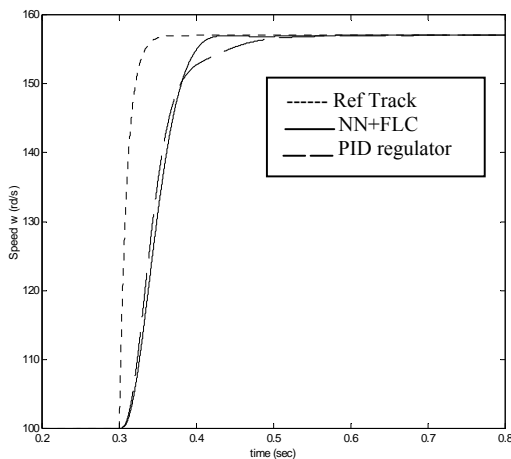

Fig.12 Tracking property with the proposed control scheme and The PID control scheme

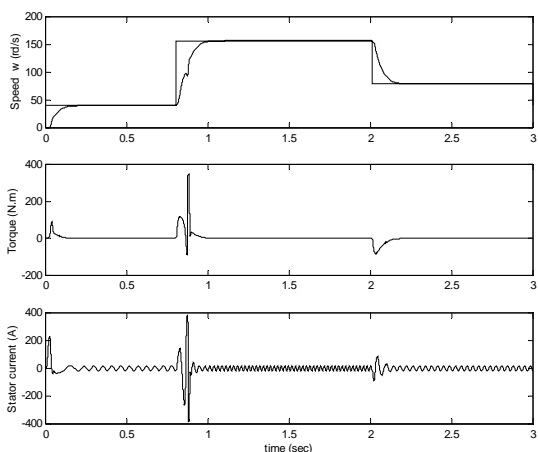

Fig. 10 Speed response following a variable reference

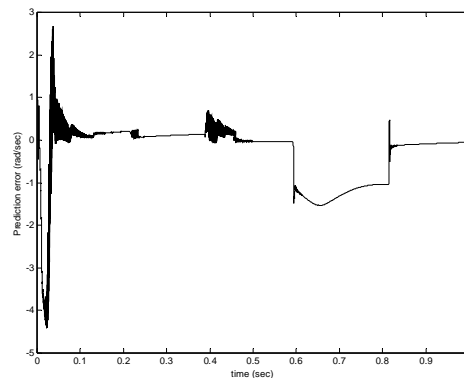

Fig. 13 Neural network model prediction error

### VIII. CONCLUSION

This paper has presented a fuzzy-neural network scheme for controlling the speed of induction motor. The system was analysed and designed, and performances were studied extensively by simulation to validate the theoretical concepts. A dynamical neural network is used to identify the plant on-line and the control signal is then calculated iteratively according to the responses of a reference model and the identified neural model of the process. Theoretical analysis and simulation results demonstrated that the proposed control scheme could accurately and rapidly predict the induction machine dynamics. The proposed control scheme had a good speed response, regardless of parameter variations or external force. The resulting are promising and further studies on similar schemes will be carried out.

### REFERENCES

- [1] C.M. Liaw, Y.S. Kung and C.M. Wu Design and implementation of a high-performance field-oriented induction motor drive. IEEE Trans. Ind. Electron., vol.38,4,pp.275-282,1991.
- [2] M.A. Wishart and R.G. Harley. Identification and control of induction machines using artificial neural networks. IEEE Trans. Ind. Applicat., vol.31,pp.612-619, 1995.
- [3] Y.S. Kung, C.M. Liaw and M.S. Ouyang. Adaptive speed control for induction motor drives using neural networks. IEEE Trans. Ind. Electron. Vol.42,1,pp.25-32, 1995.
- [4] T.C. Chen and T.T. Sheu. Robust speed-controlled induction motor drive based on model reference with neural networks. Inter. Journ. Of Knowledge Based Intelligent Engineering System. Vol.3,3,pp.162-171, 1992.
- [5] Levin and K.S. Narendra. Control dynamics systems using neural networks: Controllability and Stabilization . IEEE Trans. on Neural Networks, Vol.4,No.2, March 1993.
- [6] K.S. Narendra and K. Parthasarathy. Identification and control for dynamical systems using neural networks . IEEE Trans. Neural Networks, NN-1,1,4-27, 1990.
- [7] Y. Edward, Y. Ho and C. Paresh .Control dynamics of speed drive systems using sliding mode controllers with integral compensation . IEEE Trans. On Industry Applications, Vol.,27, No.5, Sept-Oct. 1991.
- [8] Jie Zhang and T.H. Burton. New approach to field orientation control of CSI induction motor drive. IEE Proceedings, Vol.135,Pt. B. No.1; January 1988.
- [9] B. Burton and F. Kamran. Identification and control of induction motor stator currents using fast on-line random training of neural networks . IEEE Trans. on Industry Applications, Vol.33,No.3,May-June,1997.
- [10] D. Nguyen and B. Widrow. Improving the learning speed of two layer neural networks by choosing initial values of adaptive weights. Proc. Int. Joint Conf. Neural Networks, San Diego, CA, pp.21-26, July, 1990.

- [11] G.C.D. Souza, B.K. Bose and J.G. Cleland. Fuzzy logic based on-line efficiency optimization control of an indirect vector controlled induction motor drive, IEEE-IECOM Conf. Maui, HI, pp.1168-1174, november 1993.
- [12] G.C.D. Souza and B.K. Bose. A fuzzy set theory based control of a phase controlled converter DC machine drive, IEE-IAS Annu. Meeting Conf. Rec., Dearborn, MI, pp.854-861, October 1991.
- [13] Q. Li , S.K. Tso and A.N. Poo. PID tuning using neural networks, Intelligent Automation and Control TSI Press Inc., USA, pp.461-465, 1998.



**M. Zerikat** (M'05) received the B.S degree in electrical engineering and the M.S. and Ph.D degrees in electronics and control systems from the University of Sciences and Technology of Oran, Algeria, in 1982, 1992, and 2002, respectively. Following graduation, he joined the university as a lecturer. He is currently a professor in the department of electrotechnics engineering. His current research includes electrical machines, high-performance motor drives modelling and adaptive control systems, image processing and development of intelligent application. He is actively involved in many projects with industry while engaged in teaching, research and consulting in the area of artificial intelligence. Actually he is associate Professor at Electrical Engineering Institute ( ENSET) of Oran- Algeria. He has authored more than 40 technical papers published in international journals and conference proceedings. He authored a book on Automatic control, which was recently published and regularly gives tutorials and industrial courses on these subjects.

Dr. Zerikat is a chairman of the institute of electrical and electronic engineers in the state of Algeria. He is regularly reviews papers for several journals in his area. He is an active member of the industrial COST Education Committee.



**M. Bendjebbar** was born on August, 16, 1965 in Relizan Algeria. He received his B.S degree in Electrical Engineering from the University of Sciences and Technology of Oran, Algeria, in 1989, and the M.S degree from the same University of Sciences and Technology of Oran, in 1993. He is currently Professor of Electrical Engineering at the University of Sciences and Technology of Oran. His research interests include

Electrical machines and Drives Control, Power Electronics, as well as Intelligent Control.



**N. Benouzza** was born on August, 17, 1963 in Oran Algeria. He received his B.S degree in Electrical Engineering from the University of Sciences and Technology of Oran, Algeria, in 1989, and the M.S degree from the same University of Science and Technology of Oran, in 1993. He is currently Professor of Electrical Engineering at the University of Sciences and Technology of Oran. His research interests include

Electrical machines and Drives Control, Power Electronics, as well as Electrical machines Faults Diagnosis.