

Retarding Potential Analyzer Design and Result Analysis for Ion Energy Distribution Measurement of the Thruster Plume in the Laboratory

Ma Ya-li, Tang Fu-jun, Xue Yu-xiong, Chen Yi-feng, Gao Xin, Wang Yi, Tian Kai, and Yan Ze-dong

Abstract—Plasma plume will be produced and arrive at spacecraft when the electric thruster operates on orbit. It's important to characterize the thruster plasma parameters because the plume has significant effects or hazards on spacecraft sub-systems and parts. Through the ground test data of the desired parameters, the major characteristics of the thruster plume will be achieved. Also it is very important for optimizing design of Ion thruster. Retarding Potential Analyzer (RPA) is an effective instrument for plasma ion energy per unit charge distribution measurement. Special RPA should be designed according to certain plume plasma parameters range and feature. In this paper, major principles usable for good RPA design are discussed carefully. Conform to these principles, a four-grid planar electrostatic energy analyzer RPA was designed to avoid false data, and details were discussed including construction, materials, aperture diameter and so on. At the same time, it was designed more suitable for credible and long-duration measurements in the laboratory. In the end, RPA measurement results in the laboratory were given and discussed.

Keywords—Thruster plume ion energy distributions, retarding potential analyzer, ground test.

I. INTRODUCTION

THE Electric Propulsion (EP), thanks to its intrinsically high specific impulse and other significant advantages to the customer, is used more and more broadly in different orbit spacecrafts especially for GEO satellites and large LEO satellites.

Due to the expansion and the energy of the jet, the plume will have physical, mechanical, thermal and electrical effects on surfaces, sub-system and instruments of the spacecraft [1]. So that, it's imperative to gain information of the plume of the electric thruster as more as possible.

During the development of the thruster and before its application on the spacecraft, it is significant for evaluating the thruster performance and its distribution in space, especially

Ma Ya-li is with the Science and Technology on Material Performance Evaluating in Space Environment Laboratory, Lanzhou, 730000, China (phone: 86-931-4585619; fax: 86-931-8265391; e-mail: fengyd2008@gmail.com).

Tang Fu-jun is with the Science and Technology on Vacuum & Cryogenics Technology and Physics Laboratory, Lanzhou, 730000, China (e-mail: yudong_feng@sina.com).

Xue Yu-xiong is with the Science and Technology on Vacuum & Cryogenics Technology and Physics Laboratory, Lanzhou, 730000, China (e-mail: lxueyxx-510@163.com).

optimization of design of Ion thruster through data achieved from laboratory test.

Usually, LP (the Langmuir Probe) and RPA are used together to verify the plume characteristics. RPA are used extensively in the field of electric propulsion to characterize the ion energy distributions in thruster plumes.

II. MECHANISM OF RPA

RPA is a flat gridded probe, consists of a series of electrodes which are separated by insulated washer each other. A collector standing under some grids collects an ion current which varies as a function of the ion retarding electrode potential [2]. The cross section drawing of the essential RPA probe [3] is sketched in Fig. 1.

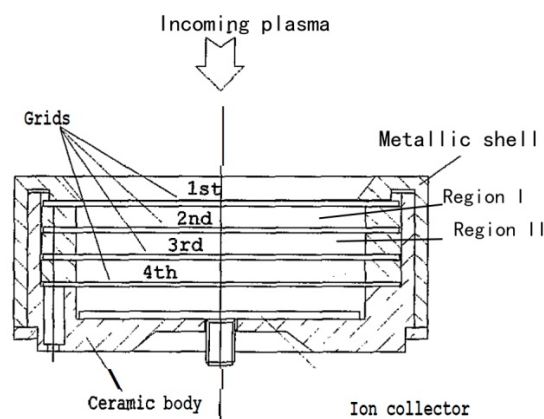

Fig. 1 RPA schematic cross-section drawing

The first grid is the entrance grid which structurally is tied to the S/C ground on orbit. It separates the inner part of the RPA from the outer space. The second grid is the primary electron repeller which filters electrons coming from the external environment by adding enough negative potential relative to the S/C ground. When ions and electrons of plasma enter the analyzer through the entrance grid (1st grid), positive ions will be accelerated toward negatively biased 2nd grid (the primary electron repeller) while incoming electrons will be repelled. Those electrons whose energies lower than the applied voltage will be repelled and be carried away by the power supplier ultimately.

After passed the second grid, positive ions are decelerated. The third grid is an ion selecting grid which is supplied with variable voltage. Only ions whose energy can overcome the retarding voltage applied on the retarding grid can pass through this grid and collected by the collector.

The fourth grid is used for filtering the secondary electrons which internally generated by the collision of ions with RPA internal parts. This grid is supplied with negative voltage relative to S/C ground in order to prevent the secondary electrons arriving at the collector and bringing error to measurement.

The collector gathers the ion finally arrived at it and the current varies as a function of the ion retarding electrode potential. The relationship [3] between them is expressed as follow:

$$f\left(\frac{E_i}{q_i}\right) = \frac{m_i}{q_i^2 e^2 n_i A_c} \left(-\frac{dI}{dV}\right) \quad (1)$$

where E_i is the ion energy, q_i is the ion charge, n_i is the ion density; m_i is the ion mass; A_c is the effective collector area.

For the same type of ion, it has the following relationship:

$$f(V) = f(E_i/q_i) \quad (2)$$

So that, dI/dV is proportion to the ion retarding electrode potential. So the potential distribution function is equivalent to the energy distribution function.

III. RPA PROBE DESIGN

While RPA operation is fairly straight forward, we should pay attention to some physical phenomena which are related the energy resolution, the test validity and the test accuracy. In order to measure perfectly, the inter-electrode spacing, the grid aperture size, the grid thicknesses and the voltage supplied should be considered carefully and designed for proper values.

A. The primary Electron Repeller

When the plasma encounters the primary electron repeller, it must meet two conditions for preventing all electrons from incoming plasma.

a) The grid aperture diameter should be smaller than the Debye length in order to minimize the Debye shielding. If the aperture is many times larger than the Debye length, the voltage impressed on the grid will not permeate the bulk of the plasma, allowing it to pass through.

b) The effective potential at the grid aperture must larger than the maximum of the electrons.

B. Space Charge Effect Analysis

After passing through the primary electron repeller, all particles in Region II are ions. For a given voltage on the ion selecting grid, Region II will be full of ions with different energies then cause space charge effect. That is, the presence of

the ion charge density in Region II raises the potential above the vacuum level [4].

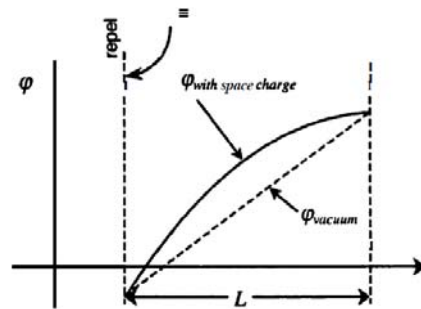

Fig. 2 The potential variation in Region II with and without space charge included

It must ensure that the potential between Region II never exceeds the sweep grid voltage corresponding to the ion energy.

The study shows that the maximum density allowed at the electron repeller grid should be lower than a critical value related with the minimum ion kinetic energy E at the electron repeller grid and the grid separation L . Otherwise potential peak higher than the ion retarding grid will appear in Region II, the ions will be repelled by this potential hill and then will lead to erroneously low ion energy measurements. In SI units, Green's relationship [5] is expressed as follows:

$$n \leq \frac{4 \epsilon_0 E}{9 e^2 L^2} \quad (3)$$

C. Electrostatic Lens Effects

Because of the presence of the grid aperture and RPA's close-spaced electrode configuration, the effective potential at the aperture is always lower than the supplied voltage.

Due to different field strength on either side of each grid and the presence of the grid aperture, electrostatic lens effects occur inside the analyzer. The stronger field always penetrates in the region of the weaker field, so that the equipotential lines bulge through the apertures and form convex surfaces towards the weaker field, as indicated in Fig. 3[6].

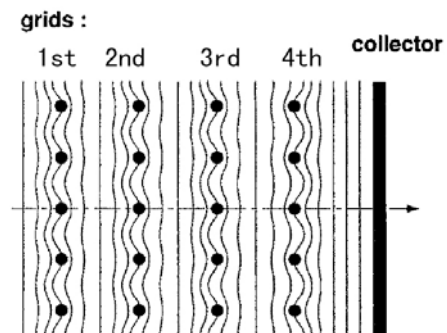

Fig. 3 Qualitative sketch of equipotential lines of the electric field inside the analyzer

The influence factors relative to the effective potential include the grid thickness, aperture size, grid gap.

Using PIC code [7], the effective potential of each grid can be calculated for applied potentials, grid spacing, grid thickness and aperture size.

D. RPA Design Used for Ion Thruster Plume Laboratory Measurement

Based on the above key factor analysis, RPA test system was designed which can be used for either thruster direct flux or CEX (charge exchange) flux measurements in laboratory.

The direct flux has properties such as high energy and high flux density. In order to get the plasma characteristics and stability in time when the ion thruster operates for long duration, the designed RPA must be suitable for long-duration test. So it becomes possible for evaluation and optimization of the ion thruster through the test data.

The designed RPA probe structure is showed as Fig. 4.

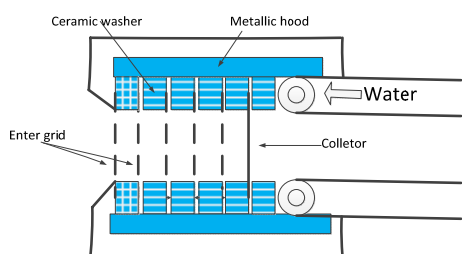

Fig. 4 Schematic cross-section drawing of the designed RPA probe

All analyzer grids are made of stainless steel 316 and the thickness is 0.2mm.

All grids except the entrance grid have the same transparency about 0.5. The collector is made of Mo due to its low electron emission coefficient.

(1) Double entrance grids

This probe was designed to monitor the direct flux of 20cm diameter Xe ion thruster and it operated at 100 mm~600mm axial distance on the thruster centerline where the electron temperature was approximated as 0.5~5 eV and the maximum density was about $1 \times 10^{16} \text{m}^{-3}$. The minimum aperture diameter was set to 0.3mm (in regard to the 316 electrochemically-machined level). So we set 0.3mm as plasma Debye, then the usable density was about $3 \times 10^{14} \text{m}^{-3} \sim 3 \times 10^{15} \text{m}^{-3}$. It meant the entrance grid should attenuate the outside plasma at least 10 times. So that double entrance grid was designed. The first grid has transmission of 10% and the second grid has transmission of 20%. The plasma density became 1/50 of the incoming plasma. The other grid transmission was 50%.

The electron repeller voltage was set to -30V so that the minimum ion energy could be considered as 30eV. The biggest gap between 2nd grid and 3rd grid allowed could be calculated by equation (2) after setting the attenuation of the entrance grid and the electron repeller voltage. The calculated gap was 2.7mm, so 2mm was chosen as the grids' gap.

(2) Grid thickness design

For certain grid gap and voltage, we found that the effective decelerating potential of the ion retarding electrode was greater than 98% of the applied potential when the electrode thickness was 0.2mm.

(3) Thermal effect

The thermal flux (including electrons and ions) received by surfaces might increase temperature and cause damage to materials due to high density of the direct flux, so it was needed to choose ceramic as the insulating material in RPA.

Also, the water-cooled copper housing was contacted with the entrance grid firmly (showed in Fig. 4) for long-duration operation.

Furthermore, the cable was spot welded to the grids to prevent melt of the low temperature solder due to the thermal focus.

(4) ceramic washer design

For laboratory test, sputtering deposition may be caused by high energy ion bombardment with grids. The washer with deposit product may arise short circuit between two grids so that the washer must adopt a maze structure.

With regard to CEX plasma, due to its lower density than the direct flux, the first grid of the entrance grid can be removed and accomplish measurements of the CEX plasma characteristics.

IV. EXPERIMENT SYSTEM AND RESULTS

A. Test System

The test system is showed as Fig. 5. Voltages are supplied by power supplies and ion current is monitor by Keithley 6517A. A computer is used for data record and treatment.

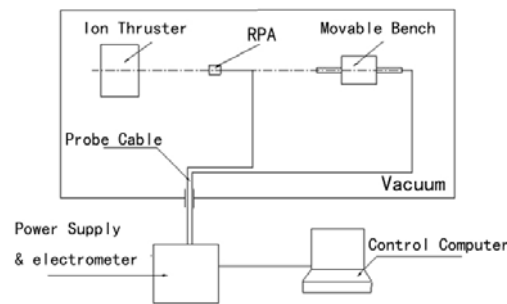

Fig. 5 diagram of plasma test system

B. Experiment Results and Discussion

(1) CEX plasma test results

The RPA was used to get ion energy distribution of the CEX plasma.

In theory, the electron repeller is considered effective for filtering the CEX electrons (0.5~5eV) when the grid potential is set to -30V.

Some unexpected phenomena were found as follows:

a) In condition that the electron repeller voltage is -30V, as can be seen in Fig. 6, the ion current becomes negative as the ion retarding voltage increases. The value becomes more and more negative as the voltage becomes larger and larger.

b) If we adjust the electron repeller voltage more negative, the ion current will be larger and the ion retarding potential becomes more positive than before. Also, the absolute value of the minimum current becomes smaller than before. If we reduce the electron repeller voltage more negative continually, the ion current will become positive and it will keeps constant as the grid 2 voltage changes in a certain range. This is showed in Fig. 6.

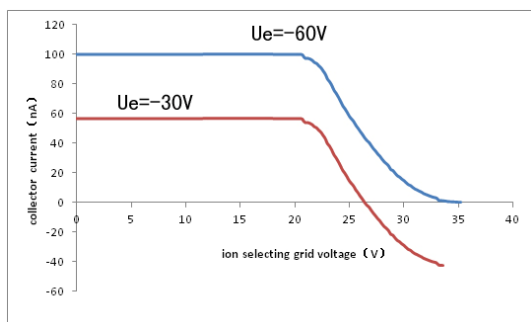

Fig. 6 The influence of the electron repeller voltage on the test

We considered that the negative value coming from the secondary electrons induced by impingement of ions on vacuum walls and other metal materials. These electrons have energy of 0-100eV higher than energy of electrons from thruster plume. The electron repeller can't filter them when it is set to -30V, so that the ion current measured is sum of these secondary electrons and ions. When the ion retarding grid voltage increasing higher than a certain value part of ions are prevented, the current collected mainly consists of these electrons and becomes negative.

In order to acquire more accurate energy distribution of ion, the primary electron repeller must be supplied with more negative voltage. Usually -100V is enough.

(2) Direct flume test results

RPA was used to get energy distribution of direct flume of ion thruster.

Some positions at the centerline were chosen for test. Results were showed in Fig. 7 only for distance of 100mm and 600mm. Apparently, there are some features as follows:

a) The maximum current is different. The current becomes smaller as the distance increase. The current is about 240 μ A at 100mm but 70 μ A at 600mm.

b) The ion energy has narrow distribution. It can be seen that the current almost the same when the ion retarding grid potential is smaller than 850V.

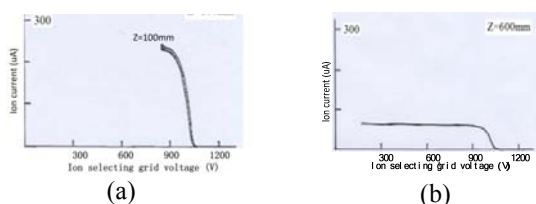

Fig. 7 The I-V curve for ion thruster direct flux

From the I-V curve the energy spectrum of the plasma ions can be obtained using numerical differentiation algorithms.

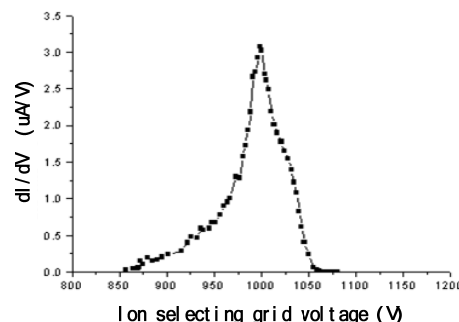

Fig. 8 dl/dV curve for ion thruster direct flux

It can be concluded that the flume has different ion densities along the centerline. The density reduced as the distance increases. The ion energies focus on 950eV~1050eV.

V. CONCLUSION

The major issues in design of RPA used in laboratory have been described carefully. RPA test system was designed suitable for long-duration and high precision measurement of the ion thruster flume performance. Some significative results were achieved.

REFERENCES

- [1] M. Perdu, D. Borie, F. Sainct, Th. Grassin, In Orbit Experimental Package For Electric Propulsion Interaction, 46th International Astronautical Congress, October 2-6, 1995/ Oslo, Norway.
- [2] Lyon Bradley King, Ph.D. Thesis, Transport-property and Mass Spectral Measurements in the Plasma exhaust Plume of a Hall-Effect Space Propulsion system [D].University of Michigan, Department of Aerospace Engineering, 1998.
- [3] M. Capacci, G. Matticari, G. Noci and A. Severi, An Electric Propulsion Diagnostic Package for the Characterization of the Plasma Thruster/Spacecraft Interactions on STENTOR Satellite, AIAA 99-2277, 35th AIAA/ASME/ASAE/ASEE Joint Propulsion Conference and Exhibit 20-24 June 1999.
- [4] Timothy Glover, Ph.D. Thesis, Measurement of Plasma Parameters in the Exhaust of a Magnetoplasma Rocket by Gridded Energy Analyzer and Emissive Langmuir Probe[D]. RICE UNJVERSITY, 2002.4.
- [5] Green, T. S., Plasma Physics, Vol. 12, 1970, p. 877.
- [6] Christian Böhm and Jérôme Perrin, Retarding-field analyzer for measurements of ion energy distributions and secondary electron emission coefficients in low-pressure radio frequency discharges, Rev.Sci.Instrum., Vol.64, No.1, January 1993, P31-p44.
- [7] Colleen M. Marrese, Neha Majumdar, James M. Haas, George Williams, Lyon B. Ring, Alec D. Gallimore, Development of a Single-orifice Retarding Potential Analyzer for Hall Thruster Plume Characterization, IEPC-97-066.

Ma Ya-li is currently a research engineer in Lanzhou Institute of Physics in Gansu, China. His reach has been focused on the space environments and effects.