

A Worst Case Estimation of the Inspection Rate by a Berthing Policy in a Container Terminal

K.H. Yang

Abstract—After the terrorist attack on September 11, 2001 in U.S., the container security issue got high attention, especially by U.S. government, which deployed a lot of measures to promote or improve security systems. U.S. government not only enhances its national security system, but allies with other countries against the potential terrorist attacks in the future. For example CSI (Container Security Initiative), it encourages foreign ports outside U.S. to become CSI ports as a part of U.S. anti-terrorism network. Although promotion of the security could partly reach the goal of anti-terrorism, that will influence the efficiency of container supply chain, which is the main concern when implementing the inspection measurements. This paper proposes a quick estimation methodology for an inspection service rate by a berth allocation heuristic such that the inspection activities will not affect the original container supply chain. Theoretical and simulation results show this approach is effective.

Keywords—Berth allocation, Container, Heuristic, Inspection.

I. INTRODUCTION

THE mature global supply chain system makes the convenient transportation between contraries possible, and lets goods transport in a highly efficient way. Of all the transportation modes, the maritime transportation plays the most important role in the global supply chain system. Such as the United States, the maritime transportation is highly related to its economy. According to the statistics of 2005 from U.S. Bureau of Transportation, 75% of goods imported to or exported from U.S. are transported by maritime transportation, of which is mainly containerized trade. Each year more than six million containers are offloaded at US ports. Containerized trade is not only booming in the U.S., but other countries are. Some other historical statistics [1] showed that around 90% of the world's cargos are moved by vessel and each year over 48 million full containers are transported between major ports in the world. Such a huge amount container transportation flow makes a container terminal play an important role in the supply chain transportation network. Therefore, the shipping containers and its transport system are vital components to the global supply chain [9].

Although the container inspection is one of the terminal operations, it is not highly taken seriously until the terrorism attack on September 11, 2001 in the United States. Before 2001,

port security measures mainly focused on reducing cargo theft, stowaways, and smuggling. An example of the U.S. Custom, only 2% to 4% of several million containers shipped to U.S. were physically examined yearly [7]. In this case, a low inspection rate on the containers makes crime possible to smuggle weapons into the U.S. territory by shipping containers. After the terrorism attack, U.S. government started to pay highly attentions on the security issues, especially maritime security, which would potentially obstruct its economical growth in the future. [11] held a war game simulation experiments for a major U.S. seaport under several terrorist scenarios and concluded successful attacks would not only harm U.S. economy but also global trade.

Since 2001, U.S. government aggressively adopted and implemented new technologies, regulations, and operating process and protocols to prevent the potential terrorist threats. Most of the new measures focused on container terminal operations, including policy measures and technology measures. [9] listed policy measures which included Customs-Trade Partnership Against Terrorism (C-TPAT), Container Security Initiative (CSI), and Maritime Transportation Security Act of 2002 (MTSA) and technology measures, which included Operation Safe Commerce (OSC), Antitamper Seals, Radio-Frequency Identification, X-Ray and Gamma-Ray Scanning, Radiation Pagers, Portal Sensors. In the study, they concluded that security and efficiency are two distinct but interconnected issues in the global supply chain. Improvement on the efficiency of the system may or may not influence the security of the system. However, increasing a security level will reduce efficiency of the system. For example, inspecting more containers will delay the transporting container cargo and further lead to negative economic effects. In order to increase the efficiency of the inspection operations, a lot of researchers focused on developing or improving a high-tech screening device or technology to facilitate the inspection process, such as [2] [4] [5] [6], and etc.. Those studies mainly solved the problems based on the technological perspectives. Not the same as the berth allocation problem, the quay scheduling, or the storage yard operation problem, the container inspection problem is seldom studied based on the operational perspectives. Only few studies discussed the relevant issue, such as [1] established a large-scale linear programming model for finding optimal container inspection strategies under varies limitations, including budget, sensor capacity, time limits, etc. [8] adopted a simulation-based

K. H. Yang is with the Department of Industrial and Systems Engineering, Chung Yuan University, Chung Li, Taiwan, 32023, R.O.C. (corresponding author to provide phone: 886-3-2654428; fax: 886-3-2654499; e-mail: kanghungyang@cycu.edu.tw).

approach to find the balance of diverse of conflicting objectives, for instance, considering efficiency and security factors into the objective function to determine inspection strategies.

[3] combined the operations research and simulation approaches to establish an embedded model with a berthing heuristic, developed by [13], to study how to estimate the best inspection service rate for a container terminal. In the study, numerical lower bound of the service rate was demonstrated by the embedded model. Three potential issues make the study lack of completeness; first, the numerical lower bound probably depends on different scenarios; second, the berthing heuristic is suitable for the linear type terminal. If the topology of a terminal is not linear, the results might be deviated; third, an important assumption for the berthing heuristic is the 'agreeable' assumption [13] [14], i.e., a longer length vessel has a longer processing time. This assumption might be not right in the real world. In this paper, a modified heuristic is proposed to consider the terminal topological factor. At the same time theoretical lower bound is deduced to guarantee the solution quality of the modified heuristic. Also, collected real data are analyzed to examine the validity of the "agreeable" assumption to make conclusions solid.

II. RELATIONS BETWEEN BERTHING AND INSPECTION OPERATIONS

When a container vessel arrives at a port, it has to be berthed at an assigned location. Then quay cranes are assigned to unload containers on the vessel to the landside or load a container from a truck to the vessel. A quay crane will finish an unloading operation first, and then it will start then loading operation. Once a quay crane finishes its jobs; it will move to another location to continue other assigned jobs or temporarily stop and wait for other instructions. The vessel will leave the terminal once it finishes all assigned jobs. The Fig. 1 demonstrates the terminal operational processes.

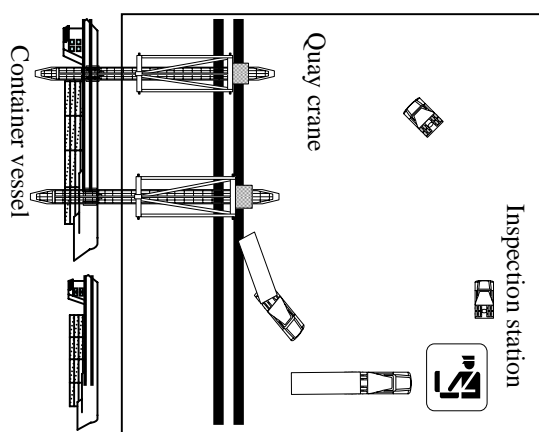

Fig. 1 Terminal operations

Before the terrorism attack, only few containers will be checked because of considering the operational efficiency. Most containers will be delivered to their destinations, and

those suspected containers will need further examinations. However, after the terrorism attack, U.S. government enhanced security measures nationally and internationally. Such as CSI policy, U.S. government asked partner countries to examine 100% of the containers to U.S. Such high container inspection rate will seriously impact the terminal efficiency

An efficient and effective terminal operational flow is mainly determined by efficient utilization of the quay cranes. Addition inspection activities will delay quay cranes operations, unless there is a reasonable inspection service such that terminal container movement is not blocked by the inspection. That is implied that the reasonable inspection service rate can be estimated by the service rate of quay cranes operations. Intuitively, we can just collect quay crane operations data and define the relationship between the quay crane operations and the inspection operation; then a reasonable inspection service rate can be determined. However, it is not true. Quay crane operations data are often confidential and not released to the public. Therefore, it is not easily to estimate the inspection service rate by this approach. However, vessel berthing data are usually on a harbor website and open to the public. Consequently, this study is trying to use an alternative approach to estimate inspection service rate by the vessel berthing policy.

During the data collection period, I interviewed some staffs who are in charge of the terminal operations in the Keelung harbor, which is located in north Taiwan. They explained that the terminal operational efficiency mainly comes from the crane operations. If we further examine the real container terminal data, we find the same conclusions from the interviews. Fig. 2. Crane operations time contributes the most part of vessel berthing time and is highly related to the vessel berthing time (correlation coefficient: 0.7).

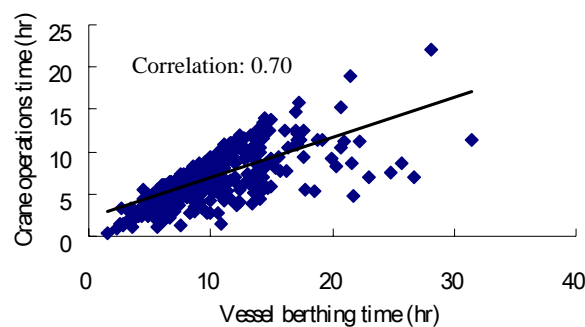

Fig. 2 Relations between vessel berthing time and crane operation time

Fig. 3 shows that the relationship of total processed containers and crane operations time is also highly correlated with each other, which indicates if berthing service rate can be estimated, an inspection service rate can be estimated as well.

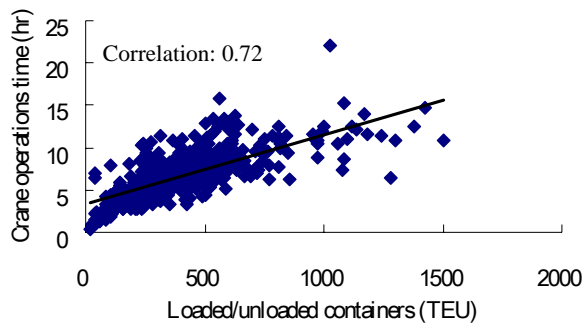

Fig. 3 Relations between crane operations time and containers that need to be processed.

[13] developed a heuristic that was mathematically proved to be an efficient algorithm for the berth allocation problem, which is based on a very important assumption, i.e. “agreeable” assumption, that is, a larger sized vessel has a longer vessel processing time, and vice versa.

Fig. 4 shows that the relationship between vessel length and vessel processing time. The result implied the weak relationship between each other. That indicates we can not precisely estimate the inspection rate by a berthing policy.

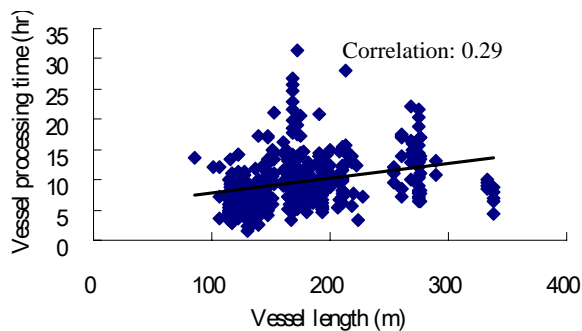

Fig. 4 Relationship between vessel length and vessel processing time

However, the “agreeable” assumption indicates that the larger vessel length will have a longer vessel processing time, which means we will over-estimate the number of containers which need to be inspected. In this case, the results will be upper bound of the problem. That is, the inspection service that we acquire from the approach is in a worst case. If the terminal operations can run smoothly in the worst case, the inspection service rate can definitely apply for all kinds of conditions in the daily operations.

Besides, Fig. 4 shows the relationship of vessel length and vessel processing time is positively correlated, which also implies the “agreeable” assumption can be used for a berthing heuristics in a “weak” sense.

III. INTRODUCTION OF THE BERTH HEURISITC

In order to apply a berthing heuristic, a vessel need to be treated as a rectangle, which is shown in Fig. 5.

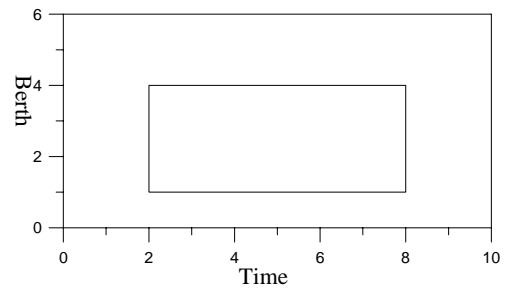

Fig. 5 A time-space representation of a vessel

Fig. 5 shows a vessel is moored from time 2 to time 8 and occupies the berths from number 2 to number 4.

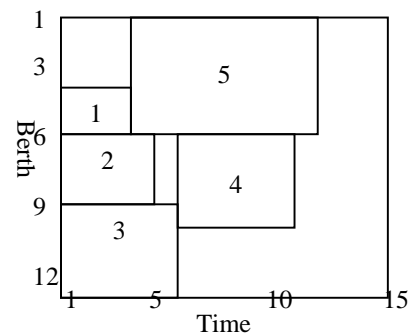

Fig. 6 A time-space representation of 5 vessels

The berthing policy I applied in this study is developed by [13], which steps are as follows,

Assume there are n vessels, the berthing time (p_i) and the length (s_i) of a vessel V_i is known, and the agreeable assumption is valid in this study, that is, $p_1 \leq p_2 \leq \dots \leq p_n$ and $s_1 \leq s_2 \leq \dots \leq s_n$. Let $t \leftarrow 1$

Step 1: Assume $\{V_t, V_{t+1}, \dots, V_n\}$ is unscheduled vessel set

Let $u = \max\{q \mid \sum_{j=1}^q s_j \leq m \text{ and } q \leq n\}$

In which, m is number of berths, and let

$G_t \leftarrow \{V_t, V_{t+1}, \dots, V_u\}$

Step 2: For $r = \ell, \ell + 1, \dots, u$

(a) if t is odd, then assign the following berths to V_r ,

$$m - \sum_{j=r}^u s_j + 1, m - \sum_{j=r}^u s_j + 2, \dots, m - \sum_{j=r+1}^u s_j$$

(b) if t is even, then assign the following berths to V_r ,

$$\sum_{j=r}^u s_j + 1, \sum_{j=r}^u s_j + 2, \dots, \sum_{j=r}^u s_j$$

Step 3: $t \leftarrow t + 1$ go to Step 1 until all vessels are scheduled.

IV. THEORETICAL LOWER BOUND OF INSPECTION SERVICE RATE

In order to derive the theoretical inspection service rate, first, the symbols are defined as follows,

A_1 : number of berths times the finish time (makespan) of the last vessel

A_2 : sum of areas of all vessel rectangles

ρ : A_2/A_1

γ_p : service rate of a berth, expressed by container throughput per time unit

γ_c : service rate of a crane,

γ_i : service rate of the inspection station

c : the ratio between the time of cranes serving a vessel and the time of the vessel berthing.

In this study, we apply a berthing policy to estimate inspection service rate. In a terminal with m berths, if we establish one inspection center to examine all containers that need to be loaded or unloaded, the best guess of the inspection rate is m times of the berthing service rate, in which m is the number of berths. However, from the observations of Fig. 6, vessel rectangles can not fully occupy the time-space domain, which implies the best guess of the inspection service rate is less than m times of the berthing service rate.

Ideally, $\gamma_p = \gamma_c$, however, in the real world, that is not the case (refer to Fig. 2), therefore, $\gamma_p = c\gamma_c$. Consequently, the inspection rate can be defined as

$$\gamma_i = m\rho\gamma_p = cm\rho\gamma_c = cm\frac{A_2}{A_1}\gamma_c$$

Since the pattern of the vessel rectangles is not predictable, A_2/A_1 is not easy to estimate. However, by using the berthing heuristic developed by [13], A_2/A_1 can be approximately estimated when there are infinite incoming vessels.

Proposition: if the processing time of each vessel p_i is finite, $A_2/A_1 \rightarrow 1/2$ as number of vessel tends to infinity.

Before the proof of the proposition, a relaxed problem has to be defined first. If the processing time of a vessel V_i is p_i and the length of the vessel is s_i , [13] defined it as s_i vessel rectangles with one unit size in its length replace the original vessel rectangle, which demonstrates in Fig. 7.

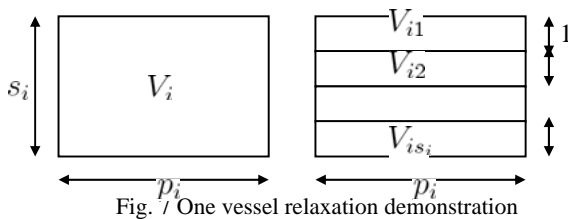

Fig. 7 One vessel relaxation demonstration

Fig. 8 shows a six-vessels berthing case by the berthing policy. Fig. 9 is the relaxed problem of Fig. 8 by the SPT rule

(shortest processing time first). Let C_i^H be the completion time of V_i (the i^{th} vessel) and C_{i1}^R be the completion time of the first vessel rectangle of V_i in the relaxed problem, for $i=1, \dots, n$. According to the Lemma 3 in [13], $C_i^H \leq 2C_{i1}^R$ for every i . Take Fig. 8 and Fig. 9 for example, $C_6^H \leq 2C_{61}^R$

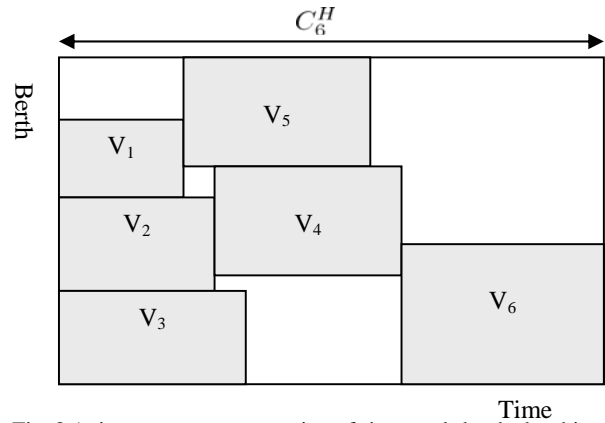

Fig. 8 A time-space representation of six vessels by the berthing policy

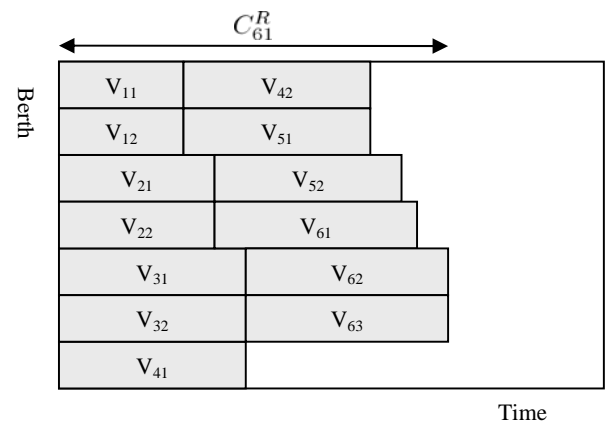

Fig. 9 A relaxed problem of the case of Fig. 8

By observing Fig. 8 and Fig. 9, we can find the areas of all vessels rectangles in the two figures are the same with each other, therefore,

$$\sum_{i=1}^n p_i s_i \geq m(C_{n1}^R - \max\{p_i\})$$

Divided by $C_n^H m$ in both sides of the above inequality

$$\frac{\sum_{i=1}^n p_i s_i}{C_n^H m} \geq \frac{m(C_{n1}^R - \max\{p_i\})}{C_n^H m}$$

$$\frac{\sum_{i=1}^n p_i s_i}{C_n^H m} \geq \frac{C_{n1}^R}{C_n^H} - \frac{\max\{p_i\}}{C_n^H m}$$

As there are infinite vessels coming to the container terminal, i.e. $n \rightarrow \infty$

$$\lim_{n \rightarrow \infty} \frac{\sum_{i=1}^n p_i s_i}{C_n^H m} \geq \lim_{n \rightarrow \infty} \left(\frac{C_{n1}^R}{C_n^H} - \frac{\max\{p_i\}}{C_n^H m} \right)$$

As $n \rightarrow \infty$, $C_n^H \rightarrow \infty$ and we know that a vessel can not stay in the terminal forever, which implies p_i is a finite number,

$$\lim_{n \rightarrow \infty} \frac{\max\{p_i\}}{C_n^H m} \rightarrow 0$$

besides, $C_i^H \leq 2C_{i1}^R$ was proved by [13], therefore,

$$\lim_{n \rightarrow \infty} \frac{\sum_{i=1}^n p_i s_i}{C_n^H m} \geq \lim_{n \rightarrow \infty} \left(\frac{C_{n1}^R}{C_n^H} \right) \geq \frac{1}{2}$$

that is,

$$\rho = \frac{A_2}{A_1} \geq \frac{1}{2}$$

Consequently, if the vessel heuristic is applied for acquiring the inspection rate in the worst case, the inspection rate can be expressed,

$$\gamma_i = m\rho\gamma_p = m\rho c\gamma_c = m \frac{A_2}{A_1} c\gamma_c \geq 0.5cm\gamma_c$$

$$\gamma_i = m\rho\gamma_p = cm\rho\gamma_c = cm \frac{A_2}{A_1} \gamma_c$$

V. SIMULATION VERIFICATION OF THE THEORETICAL LOWER BOUND OF INSPECTION SERVICE RATE

In order to further verify the validity of theoretical value ρ in the worst case, we randomly simulate 10 cases that fit the “agreeable” assumption by considering $n = 3000$, $c = 1$ and $m = 12$. Fig. 10 shows our proof for the worst case bound of ρ is valid.

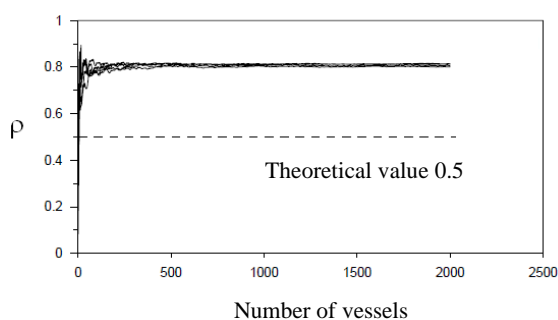

Fig. 10 Verification of the theoretical value ρ

According the collected real data of the Keelung harbor, the expected ratio between crane operations time and vessel berthing time is 0.72 with a standard 0.18, namely, c can be set to 0.72. From the statistics of Keelung harbor, it is shown that the crane service rate is approximately 25 containers/hour; under this situation, if a inspection station has to be installed, its inspection capability needs to reach at least $0.5 \times 0.72 \times 25 \times m = 9m$ containers/hour to avoid the inspection station becoming a bottleneck of the terminal operations.

VI. CONCLUDES AND SUGGESTIONS

This study applied the existing vessel berthing policy to

estimate an inspection service rate of a newly installed inspection station to avoid inefficient operations in the terminal for the worst case settings. According to the real data analyses, the commonly used “agreeable” assumption for the existing berthing heuristics is not a strong assumption but still can apply for this study in the worst case analysis. The inspection rate results might be over-estimated and need to be further studied to examine how much difference between the average case analyses and the worst case analyses. Besides, the berthing policy considers the linear terminal layout. It is worthy to consider the topographical layout factor to the approach to make this approach more applicable for the real world cases.

ACKNOWLEDGMENT

This study is supported by the project NSC 99-2218-E-033-002 of National Science Council, Taiwan.

REFERENCES

- [1] E. Boros, L. Fedzhora, P.B. Kantor, K. Saeger, and P. Stroud, “A large-scale linear programming model for finding optimal container inspection strategies”, *Naval Research Logistics*, Vol. 56, Issue 5, pp. 404-420, 2009.
- [2] J. Li, S. Ming, Y. Cao, and Y. Deng, “Monte Carlo Application in Shielding Design for an X-Ray Container/Vehicle Inspection System”, *Nuclear technology*, Vol. 168, No. 2, pp.391-398, 2009.
- [3] K. H. Yang, P. Pulat, Y. P. Guan, “Embedded simulation on a multiprocessor job scheduling system with inspection”, *Computers & Industrial Engineering*, Vol. 57, Issue 2, pp. 592-607, 2009
- [4] X. Duan, J. Cheng, L. Zhang, Y. Xing, Z. Chen, and Z. Zhao, “X-ray cargo container inspection system with few-view projection imaging”, *Nuclear instruments & methods in physics research. Section A, Accelerators, spectrometers, detectors and associated equipment*, Vol. 598, No. 2, pp. 439-444, 2009.
- [5] S. Pesente, M. Lunardon, G. Nebbia, G. Viesti, D. Sudac, and V. Valkovic, “Monte Carlo analysis of tagged neutron beams for cargo container inspection”, *Applied radiation and isotopes : including data, instrumentation, and methods for use in agriculture, industry, and medicine*, Vol. 65, No. 12, pp. 1322-1329, 2007.
- [6] J. X. Hong, X. J. Kong, and X. M. Liu, “A new and quick algorithm of shielding noises realizing in images of large container inspection system”, *Nuclear electronics and detection technology*, Vol. 26, No. 1, pp. 81-83, 2006.
- [7] M. Thibault, M. R. Brooks, and K. J. Button, “The response of the U.S. maritime industry to the new container security initiatives” *Transportation Journal*, Vol. 45, pp. 5-15, 2006.
- [8] S. Sekine, E. Campos-Nanez, J. R. Harrald, and H. Abeledo, “A simulation-based approach to trade-off analysis of port security”, *Proceedings of Winter Simulation Conference*, pp. 521-528, 2006.
- [9] H. H. Willis and D. S. Ortiz, “Evaluating the security of the global containerized supply chain”, Tech. rep., RAND, 2004
- [10] A. Roach, “Container and port security: a bilateral perspective,” *The International Journal of Marine and Coastal Law*, Vol. 18, Issue 3, pp. 341-361. 2003.
- [11] M. Gerencser., J. Weinberg and J. Vincent, *Port security wargame implications for U.S. supply chain*, Tech. rep., Booz Allen Hamilton, 2003.
- [12] D. Simchi-Levi, P. Laminsky, and E. Simchi-Levi, “Designing and managing the supply chain, 2nd ed.”, McGraw-Hill/Irwin. 2002.
- [13] Y. Guan, W. Q. Xiao, R. K. Cheung, and C. L. Li, “A multiprocessor task scheduling model for berth allocation: heuristic and worst-case analysis,” *Operations Research Letters*, Vol. 30, pp. 343-350, 2002.
- [14] C. L. Li, X. Cai and C. Y. Lee, “Scheduling with multiple-job-on-one-processor pattern,” *IIE Transactions*, Vol. 30, pp. 433-445, 1998.