

# Using LabVIEW Software in an Introductory Residual Current Device Course

B. Rajkumarsingh, S. Goolaup, and A. Galleegadoo

**Abstract**—Laboratory classes in Electrical Engineering are often hampered by safety issues, as students have to work on high voltage lines. One solution is to make use of virtual laboratory simulations, to help students understand the concepts taught in their coursework. In this context, we have conceived and implemented virtual lab experiments in connection with the study of earthing arrangements. In this work, software was developed, which aid student in understanding the working of a residual current device (RCD) in a TT earthing system. Various parameters, such as the earthing resistances, leakage currents and harmonics were included for a TT system with RCD connection.

**Keywords**—TT system, RCD, LabVIEW, Learning aids.

## I. INTRODUCTION

**E**ARTHING is a process that is used to connect all of the parts, of an electrical system, that could get charged to the general mass of earth. This is made possible by *earth electrode* which provides direct contact between a system and the earth. The resistance of the electrode determines the quality of *system earthing*. This in turn defines electrical potential of conductors relative to that of the earth's surface. Therefore this prevents a potential difference occurring between earth and parts of equipment in electrical system [1]. The main benefit of such a system is that it is maintained at earth potential (0V) and cannot accept other potentials [1]. Connecting earth to equipment provides a path for fault current to flow if defective conditions arise. Besides earthing, automatic disconnection of the supply of the installation concerned with fault is vital such that safety requirements are respected. This is usually carried out by Residual Current Devices (RCD) [1]. However, the functioning of RCD is affected by two factors namely harmonics and leakage currents causing nuisance tripping of RCDs [2, 3]. These two factors should be limited in order to ensure the normal functioning of the breaking device.

As such, practical hands-on experiment on earthing system, not only poses safety risk to students, but also, may result in many unwanted device failures. LabVIEW has been reported as an excellent tool for simulating practical systems such as Electrical Motors [4] and other systems in electronic and electrical engineering [5, 6]. Different configurations of TT systems have been simulated using LabVIEW software.

B. Rajkumarsingh, S. Goolaup & A. Galleegadoo are with the Department of Electrical & Electronic Engineering, University of Mauritius, Reduit, Mauritius. (Phone: 230-403-7985; e-mail: b.rajkumarsingh@uom.ac.mu, s.goolaup@uom.ac.mu & a.galleegadoo@uom.ac.mu).

The fundamental equations for each configuration of the TT system have been imparted into the LabVIEW for simulation purposes. The parameters introduced for simulations are based on the document of International Electrotechnical Commission (IEC) which is the world body responsible for international standardisation within the electrical industry [7].

The experiments which have been simulated for a TT system are listed as below:

- System I: The presence of both RCD and earth connections;
- System II: No RCD and no earth connections;
- System III: The presence of RCDs only and
- System IV: The presence of earth connections only.

Further two investigations, on the unwanted tripping of RCD, were carried out:

- System V: Leakage Currents on RCD tripping and
- System VI: Harmonics on RCD tripping.

## II. LABVIEW

LabVIEW stands for Laboratory Virtual Instrument Engineering Workbench which is a graphical programming language, based upon icon and buttons instead of lines and programming codes for application purposes. This software has the ability to build user defined interface with set of objects and graphical tools. These programs are labelled as Virtual Instruments (VIs), owing to their operational replica of physical instruments, like oscilloscopes, multi-meters, etc. A VI is a combination of following three components:

- a. Front panel;
- b. Block diagram and
- c. Icon and connector panel.

## III. SYSTEM MODEL

In the TT system the transformer neutral is earthed and the consumer frame is earthed as shown in Fig. 1[7].

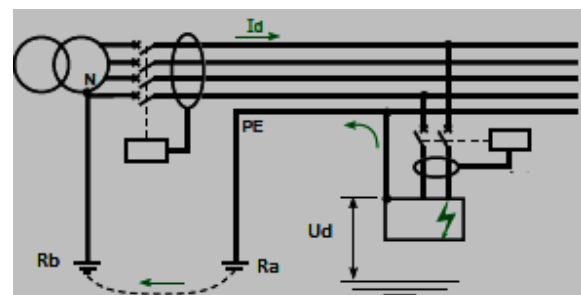

Fig. 1 The TT system

It can be seen from this figure that when an insulation fault occurs, the fault current  $I_d$  flows through earth to the neutral of the transformer and is mainly limited by the earth resistances.

Assuming that the fault resistance,  $R_d = 0$ , the fault current,  $I_d$  is given by:

$$I_d = \frac{U_d}{R_a + R_b} \quad (1)$$

where  $R_a$  is the earth resistance at the consumer's premises.

$R_b$  is the earth resistance of the neutral. The touch voltage appearing on the frame,  $U_d$  is given by:

$$U_d = I_d R_a \quad (2)$$

Depending on the value of the earth resistances, this voltage can be dangerous and this part of the installation must be isolated by an RCD.

To ensure protection of persons, the sensitivity  $I_{\Delta n}$  of the RCD must be as follows:

$$I_{\Delta n} \leq \frac{U_L}{R_a} \quad (3)$$

Where  $U_L$  is the touch limit voltage.  $U_L=50$  V for dry conditions and  $U_L=25$  V for wet conditions.

Moreover, the breaking time of the RCD should be less than the safety time,  $t_s$  given by the IEC touch voltage durations.

To ensure tripping of the RCD,  $I_d$  should be greater than  $I_{\Delta n}$

The current flowing through the body of a person is given by:

$$I_b = \frac{U_d}{R_m} \quad (4)$$

Where  $R_m$  is the resistance of human body either in dry or wet conditions.  $R_m$  is taken to be  $1000\Omega$  in the most unfavourable conditions for low voltage [8].

#### IV. IMPLEMENTATION OF THE SYSTEM IN LABVIEW

In view of understanding the role of earthing and the RCD in the TT system, various scenarios have been developed and simulated in LabVIEW and are explained in the sections below.

##### A. TT System with Earth Connections and RCD

Fig. 2 shows the front panel of the TT system with earth connections and an RCD, system I. The insulation fault is triggered through a switch. The user can select different values for  $R_a$  and as well as various sensitivities of RCD (10mA, 30mA and 100mA). The tripping of the RCD is observed through LEDs. Moreover, the fault current  $I_d$ , touch voltage  $U_d$  and the current flowing through the body of a person in contact with the frame,  $I_b$  are also indicated.

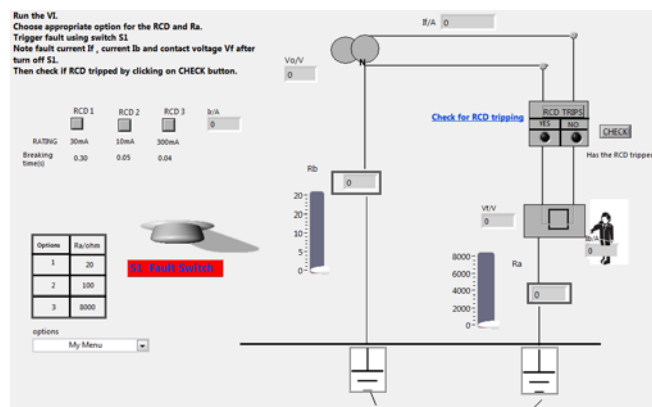

Fig. 2 Main front panel with RCD and earthing resistances

The functional code of the system proposed is given in the block diagram of Fig. 3. The values of the fault current and touch voltage indicated on the front panel are based on equations mentioned in section III. The tripping of the RCD is shown by lighting LEDs when the magnitude of the fault current is greater than its sensitivity. A case structure is used to allow selection of the earth resistances. Event structures are used to indicate the tripping and selection of the type of RCD.

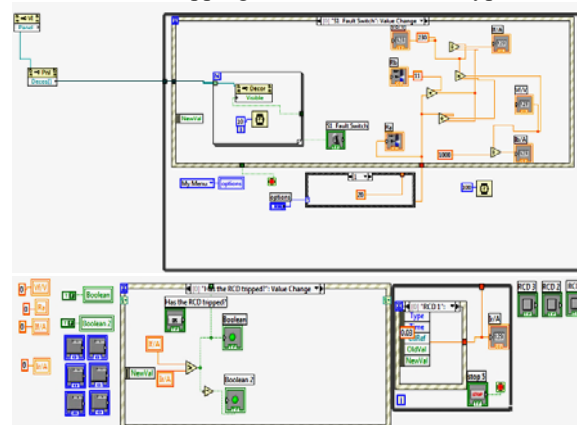

Fig. 3 Block diagram of the main system

The values of  $R_a$  for which the RCD rating tripping occurs are summarised in Table I.

TABLE I  
RESULTS FOR SYSTEM I

$R_a/\Omega$	RCD rating Ir/mA	Tripping time/ms	$I_d/A$	$U_d/V$	$I_b/A$	Did RCD trip?
20	30	300	7.42	148.4	0.148	YES
	300	150	7.42	148.4	0.148	YES
	10	40	7.42	148.4	0.148	YES
100	30	300	2.07	207.2	0.207	YES
	300	150	2.07	207.2	0.207	YES
	10	40	2.07	207.2	0.207	YES
8000	30	300	0.0281	229.7	0.230	NO
	300	150	0.0281	229.7	0.230	NO
	10	40	0.0281	229.7	0.230	YES

The user can observe that the RCD might not trip for high values of  $R_a$ . He will also understand that the choice of the sensitivity of the RCD is a critical factor in the protection of persons.

**B. TT System with No Earth Connections and No RCD**

In Fig. 4, we present a TT system with no earth connections on the consumer frame and no RCD, system II. This represents the worst case scenario where an insulation fault causes the phase to neutral voltage (230 V) to appear on the frame. This voltage is dangerous as it is greater than the touch limit voltage,  $U_L$  of 50 V. The induced fault current has no other alternative than to flow through the body of a person in contact with the frame. In this case the consequence is fatal and might lead to death. The front panel and the functional code of this configuration is shown in Fig. 5 and Fig. 6 respectively. The user can appreciate, through simulation values, the danger associated in the absence of earth connections and RCD.

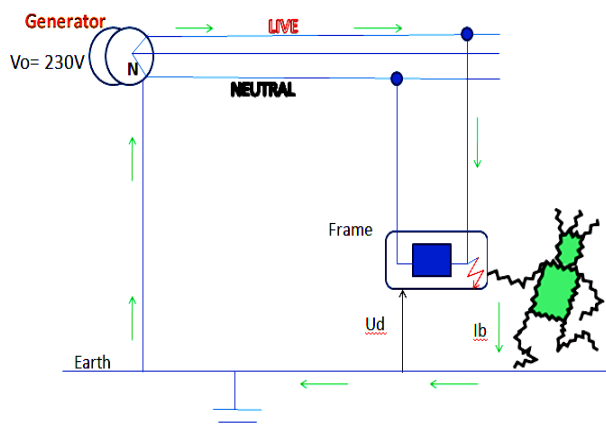

Fig. 4 Schematic of a TT system with no Earthing Resistance and no RCD

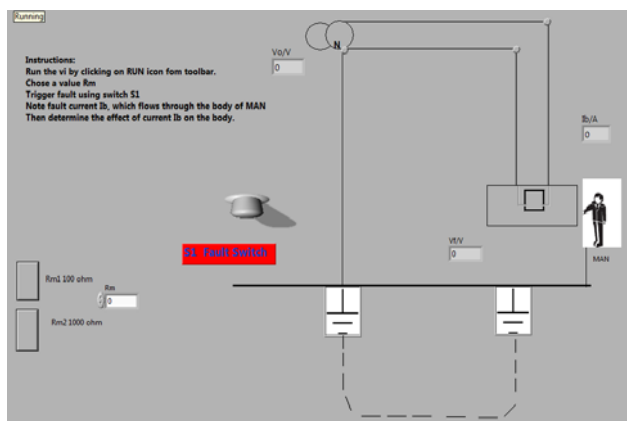

Fig. 5 Front Panel for system II

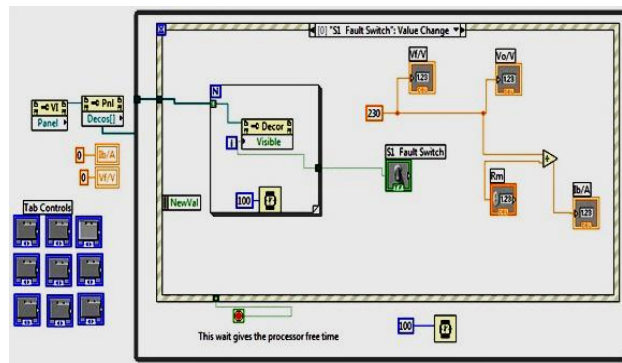

Fig. 6 Block Diagram for system II

**C. TT System with RCD Only**

A TT earthing system with RCD only, system III, is shown in Fig. 7. In this simulation, the tripping of the RCD for different values of  $R_m$  is investigated. The aim of this simulation is to understand that the RCD does protect persons even in the absence of earthing if the RCD has been properly chosen. However, the leakage current still passes through the human body and can be dangerous if the RCD tripping time is not within the electrical standards.

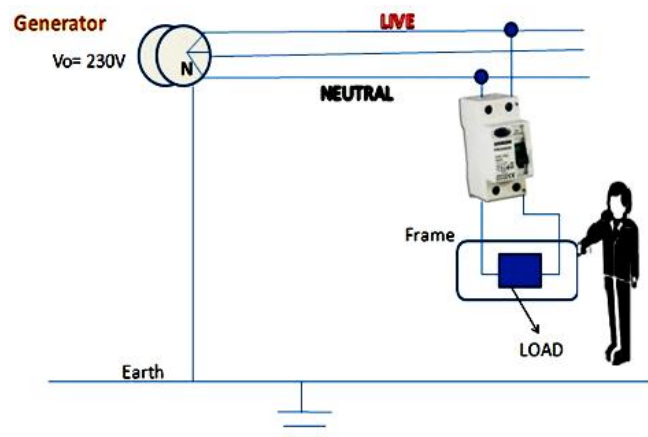

Fig. 7 TT Earthing with RCD only

In the block diagram the components are arranged similar to system II, together with two other blocks which relates namely to the RCD. These blocks help to check the tripping behaviour of the RCD and the choice of the rating of the RCD, as seen Fig. 8. In this particular simulation, the LEDs represent the RCD.

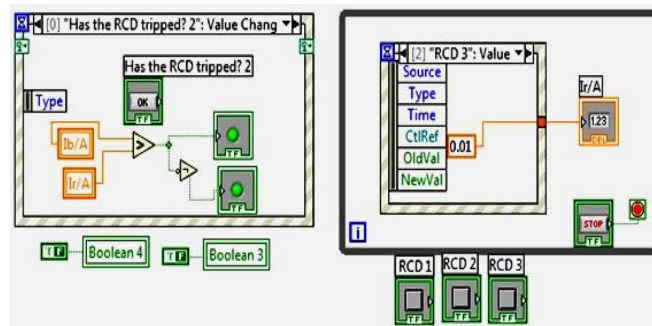

Fig. 8 TT Earthing with RCD only

Design and input parameters of system III are shown in Fig. 9.

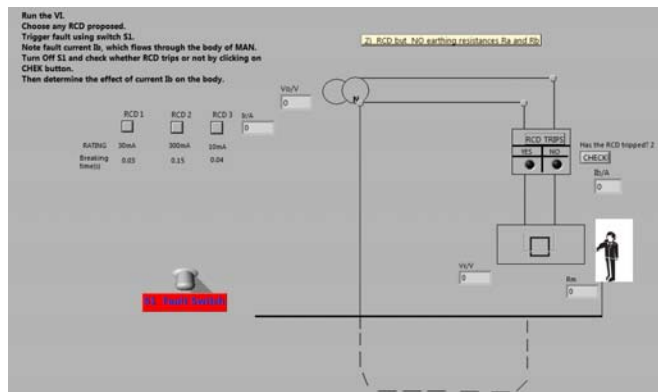

Fig. 9 Front Panel of system III

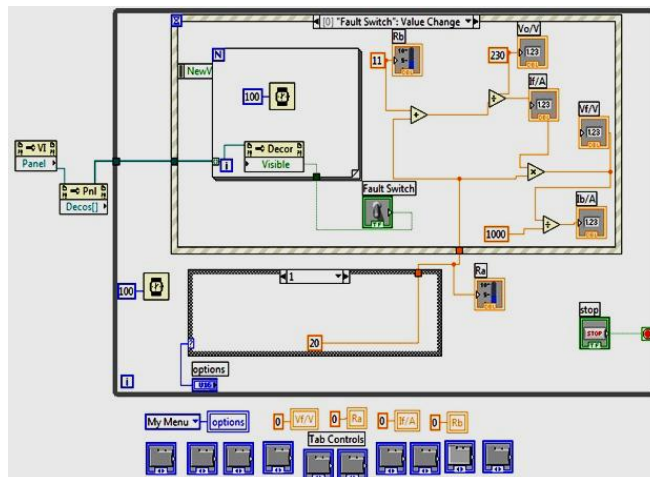

Fig. 11 Block Diagram of system IV

The corresponding front panel for System IV is shown in Fig. 12.

#### D. TT System with Earthing Resistances Only

A TT system with Earthing connections only, system IV, is shown in Fig. 10. Upon completion of this particular simulation, the importance of earthing in the TT system is highlighted. Different values of the earth resistance are used to show that for high values of earth resistance, the touch voltage on the conductive exposed part of the load becomes more dangerous in case of contact.

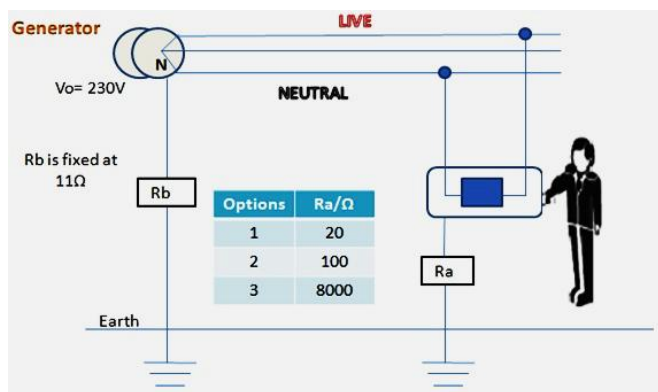

Fig. 10 Arrangement of system IV

Fig. 11 shows the block diagram including earthing resistances. Comparing this block with that modelled in Fig. 6,  $R_a$  and  $R_b$  have been added. In this particular simulation, the value of  $R_b$  is fixed at  $11\Omega$ .

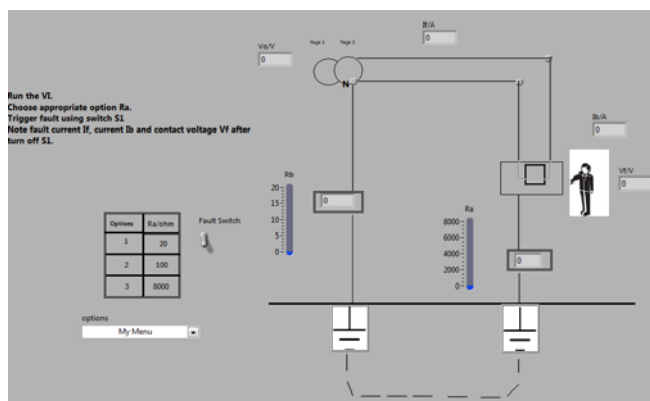

Fig. 12 Front Panel of system IV

From Table II, it can be observed that the simulated values of the touch voltage increases with  $R_a$ . Consequently, the severity of the electric shock increases.

TABLE II  
RESULTS FOR EACH VALUE OF  $R_A$

$R_a/\Omega$	$I_a/A$	$U_a/V$	$I_b/A$
20	7.42	148.4	0.148
100	2.07	207.2	0.207
8000	0.0281	229.7	0.230

#### E. Leakage Currents on RCD Tripping

The effect of leakage currents on RCD tripping, system V, is shown in Fig. 13. Standing leakage current should not exceed 30% of RCD rating as recommended by IEC i.e. 10mA for 30 mA device. One major reason is that an RCD with a 30 mA trip rating may trip anywhere between 15 and 30 mA due to component tolerances.

By the end of this simulation, the different sources of leakage currents and their contribution to unwanted tripping of the RCD will be studied. The effect of current division in the circuits can also be investigated.



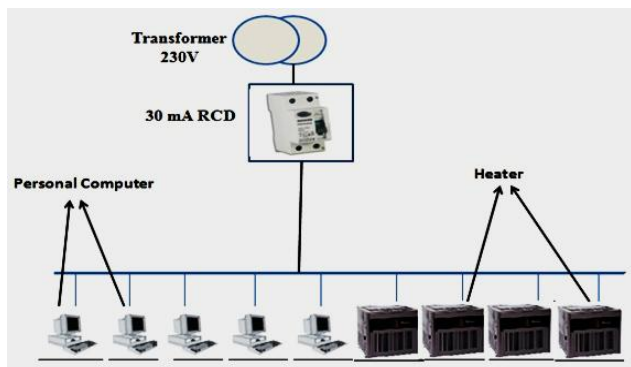

Fig. 13 Arrangement of system V

The block diagram and front panel used to represent System V are shown in Fig. 14 and Fig. 15 respectively.

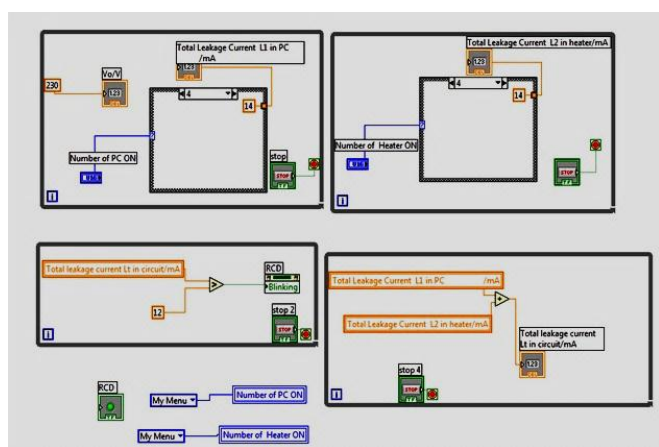

Fig. 14 Block Diagram of system V

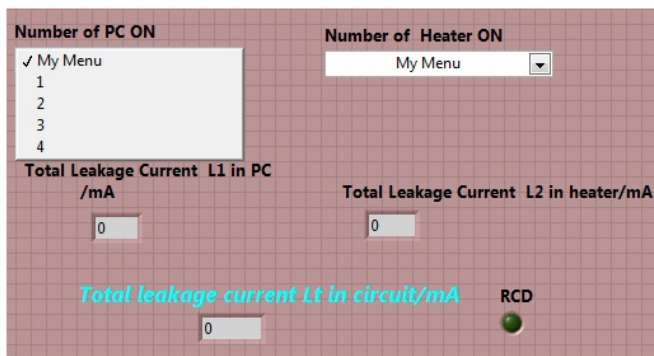

Fig. 15 Front Panel of system V

The total leakage current is obtained by summing those flowing in PCs and heaters. The overall system is completed by making the LED blink. This is equivalent to RCD tripping. Effects of leakage current on RCD tripping are shown in Table III.

TABLE III  
EFFECTS OF LEAKAGE CURRENT ON RCD TRIPPING

Number of PC ON	Leakage Current L1/mA	Number of Heaters ON	Leakage Current L2/mA	Total leakage current Lt/mA	Did RCD trip?
1	3.5	1	3.5	7.0	NO
		2	7.0	11.5	NO
1	3.5	2	7.0	11.5	NO
2	7.0		14.0	YES	
3	11.5	3	11.5	23	YES
4	14	4	14	28	YES

F. Harmonics on RCD Tripping

Harmonics are present in electrical installations and it will affect the value of the differential current and hence the tripping of the RCD. The effect of harmonics on RCD tripping, system VI has also been simulated. The block diagram for such a system is shown in Fig. 16. The resulting front panel is shown in Fig. 17.

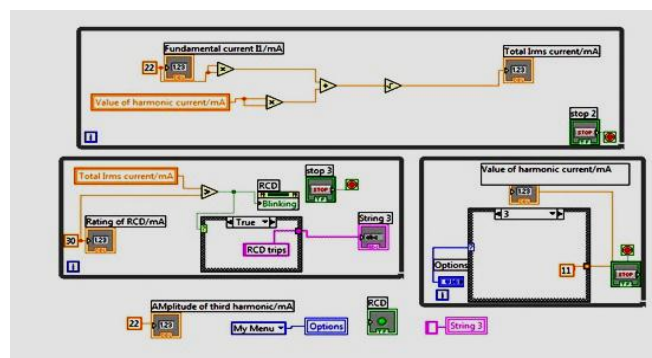

Fig. 16 Block diagram of system VI

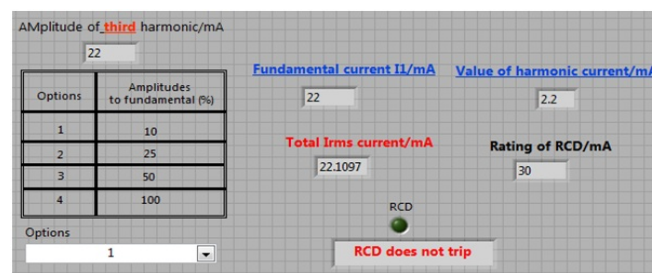

Fig. 17 Front Panel of system VI

The effects of the third harmonic on RCD tripping can be examined as an example. Table IV illustrates the outcome on the RCD.

TABLE IV  
EFFECTS OF HARMONICS ON RCD TRIPPING

Amplitude to fundamental (%)	Value of harmonic current(mA)	Total I <sub>rms</sub> current (mA)	Did RCD trip?
10	2.20	22.1	NO
25	5.50	22.7	NO
50	11.0	24.6	NO
100	22.0	31.1	YES

The total  $I_{rms}$  current involves both the fundamental current and harmonic current. The RCD sensitivity was 30 mA. From Table IV, considering 10% to 50% of harmonic current the total  $I_{rms}$  was still below the rating of the RCD. As a result the RCD did not trip, but with 100% of harmonic current, the total  $I_{rms}$  was 31.1mA. Hence the RCD tripped since the latter exceeds 30mA.

#### V. CONCLUSION

Six different earthing configurations, depicting different conditions in the TT system have been implemented in LabVIEW. Nuisance tripping of RCDs disrupts the continuity of the power supply and is a major problem in a world where a great array of electronic appliances is being used. Leakage currents and harmonic currents do affect the tripping of the RCD. We have found from students response that LabVIEW can be used as visual tool to aid beginning students to better understand the conditions leading to the tripping of RCDs.

#### REFERENCES

- [1] Raymond L.Tricker, *Wiring Regulations in Brief*, Oxford, UK, Elsevier Ltd, 2007, pp. 61-69.
- [2] Czapp, S.,*The effect of earth fault current harmonics on tripping of residual current devices*, Nonsinusoidal Currents and Compensation, 2008. ISNCC 2008, pp.1-6.
- [3] R J Dean, N Hunt and M Carter,*Effect of load on RCD test Performance*, ERA Report 2006-0642, ERA Project 7EZ060044
- [4] R. A. Jabbar Khan, A. Mohammed, M. Junaid, M. A. Masood, A. Iftkhar, *LabVIEW based Electrical Machines Laboratory for Engineering Education*, WSEAS Transactions on Advances in Engineering Education, May 2010, Issue 5, Volume 7.
- [5] Salzmann, Ch., D. Gillet and P. Huguenin. *Introduction to Real-Time Control Using LabVIEW<sup>TM</sup> with an Application to Distance Learning*. International Journal of Engineering Education "Special Issue: LabVIEW Application in Engineering Education", 2000, Vol. 16, No. 3, pp.255-272.
- [6] John T. Oldenburg, *Using National Instruments LabVIEW Software in an Introductory Electronics Course – MOSFET Transistor Parameter Estimation and Bias Circuit Design*, Proceedings of the 2004 American Society for Engineering Education Pacific Southwest Section Conference April 1-2, 2004, University of the Pacific, Stockton, CA.
- [7] Schneider Electric. (2007) Protection against electric shock.[Online].<http://www.electricalinstallation.org/enw/images/5/53/F-Protection-against-electric-shocks.pdf>
- [8] John F Whitfield, *The electrician's guide to the 17<sup>th</sup> edition of the IEE Wiring regulations BS 7671:2011 and part P of building regulations*, E.P.A press, Wendens Ambo, Salfon Walden, UK, p.108.