

# Design of Coal Quality Disturbance Free System for Coordinated Control System Based on Gain Scheduling

Liu Ji-Wei, Pei Yu-Liang, Liu Qian, Han Xiang, Zeng De-Liang

**Abstract**—The economic and stable operation was affected seriously by coal quality disturbance for power plants. Based on model analysis, influence of the disturbance can be considered as gain change of control system. Power capability coefficient of coal was constructed to inhibit it. Accuracy of the coefficient was verified by operating data. Then coal quality disturbance free system based on gain scheduling was designed for coordinated control system. Simulation showed that, the strategy improved control quality obviously, and inhibited the coal quality disturbance.

**Keywords**—coordinate control system, coal quality disturbance, energy coefficient of coal quality, gain scheduling

## I. INTRODUCTION

FUEL properties are the foundation for power plants' design. Equipment and operating methods should be used properly for different fuel. Besides that, fuel properties should be mastered by operators of power plants.

Many types of coal are used by power plants, which have great difference. Coal quality changes even if they are the same type, because of different mining time and depth, etc. Furthermore, blended coal combustion makes the change much greater. [1]

Choices are limited as the resources are in short supply for power plants. Nowadays, economic and stable operation is impacted significantly by the coal quality disturbance. [2]

The coal quality disturbance can be reflected by low calorific value, whose online detection technique is not mature yet. In this paper, history data was analyzed, power capability coefficient of coal (PCCC) was used to represent coal calorific value, which was based on gross coal consumption rate. Then, PCCC was used in coal quality disturbance free system based on gain scheduling, which can overcome the coal quality disturbance. Simulation showed that, this method could improve the performance of control system.

## II. CONSTRUCTION OF POWER CAPABILITY COEFFICIENT OF COAL

Coal quality disturbance is the problem which is concerned about most by power plants. It can't be monitored online currently, and offline assay is used which has a serious lag. [3]

In this paper, PCCC was constructed by history data, which

Liu Ji-wei is with North China Electric Power University, School of Control and Computer Engineering (e-mail: romanljw@hotmail.com)

Pei Yu-Liang, Liu Qian and Han Xiang are with Jianbi Power Plant, Guodian Corporation

Zeng De-Liang is with North China Electric Power University, School of Control and Computer Engineering

could represent coal quality.

### A. Construction of power capability coefficient of coal

The ratio of power and coal consumption is used to show coal quality on-site as follows,

$$C = M / Ne \quad (1)$$

where:  $M$ - the total amount of fuel, t/h;

$Ne$ - active power of the unit, MW.

But unit efficiency can be influenced by many factors, such as adjustment of combustion, air distribution, controller parameters changing, etc., which makes different active power even the same total amount of fuel are used. Hence, the accuracy of equation 1 is affected. Gross coal consumption rate can reflect unit efficiency, as the coal was converted into standard coal in calculation process. Therefore, the ratio calculated by equation 1 can be fixed with the help of gross coal consumption rate, in order to reduce the influence of unit efficiency. Thus, PCCC is defined as follows, which could reflect the coal quality more accurate [3]:

$$C_x = K \frac{M}{Ne * B_s} \quad (2)$$

Where:  $k$ - coefficient;

$B_s$  - gross coal consumption rate, g/kWh.

PCCC reflects the coal quality relative to the standard coal. Greater value means poor coal quality.

### B. Verification of PCCC

The ratio of total heat quantity and total amount of fuel represents coal calorific value. The methods provided in reference 4 can calculate total heat quantity accurately and conveniently. The accuracy of PCCC can be illustrated by the case of analyzing one month steady-state operational data from a 600MW sub-critical unit. The following table represents correlation coefficient between the two methods and the calculated coal calorific value.

TABLE I  
CORRELATION COEFFICIENT

	Method on-site	PCCC
correlation coefficient with calculated calorific value	0.9445	0.9596

Table I shows comparing to the method on-site, the PCCC's correlation coefficient is higher, which means more accuracy and the influence of the unit's efficiency is overcome to some extent.

### III. THE APPLICATION OF GAIN SCHEDULING ON COAL QUALITY DISTURBANCE FREE SYSTEM

Fluctuation of coal amount represents coal quality disturbance in operation. The impact to the control system should be analyzed from the model.

#### A. Impact on control system

The coal quality disturbance is represented by the change of coal calorific value, which illustrated by the example of a 500WM model as follows[5]:

$$r'_B = e^{-\tau s} u_B \quad (3)$$

$$K_f \frac{dr_B}{dt} = -r_B + r'_B \quad (4)$$

$$C_b \frac{dp_d}{dt} = -K_a p_t u_T + K_1 r_B \quad (5)$$

$$K_t \frac{dN_E}{dt} = -N_E + K_a p_t u_T \quad (6)$$

$$p_t = p_d - K_2 (K_1 r_B)^{1.5} \quad (7)$$

Where:  $u_B$ ,  $u_T$ ,  $r'_B$ ,  $r_B$  denote the fuel, turbine valve, rate of combustion, amount of coal into the boiler respectively. The outputs  $p_b$ ,  $p_t$ ,  $N_e$  denote drum pressure, steam pressure and load respectively.  $K_1$  denotes fuel gain.  $\tau$ ,  $K_f$ ,  $K_2$ ,  $K_a$ ,  $C_b$ ,  $K_t$  are internal coefficients.

The nonlinear state equations 3-7 can be transformed to transfer function as follows:

$$\begin{bmatrix} P_T \\ N_E \end{bmatrix} = \begin{bmatrix} W_{PB} & W_{PT} \\ W_{NB} & W_{NT} \end{bmatrix} \begin{bmatrix} u_B \\ u_T \end{bmatrix} \quad (8)$$

where:

$$W_{PB}(s) = \frac{K_1}{K_3 u_t} \frac{(1 - 1.5 C_b K_2 \sqrt{K_1 u_B} s)}{(1 + K_f s) \left(1 + \frac{C_b}{K_3 u_T} s\right)} e^{-\tau s} \quad (9)$$

$$W_{PT}(s) = \frac{K_1 (1 - 1.5 C_b K_2 \sqrt{K_1 u_B} s)}{(1 + K_f s) \left(1 + \frac{C_b}{K_3 u_T} s\right) (1 + K_t s)} e^{-\tau s} \quad (10)$$

$$W_{PT}(s) = \frac{\frac{K_1 u_B}{K_3 u_T^2}}{1 + \frac{C_b}{K_3 u_T} s} \quad (11)$$

$$W_{NT}(s) = \frac{\frac{C_b k_1 u_B}{K_3 u_T^2} s}{1 + \frac{C_b}{K_3 u_T} s} \quad (12)$$

Equations 9-12 show coal quality disturbance can be reflected by  $K_1$ , which modifies the gain of the model.

#### B. Gain scheduling based on PCCC

Gain scheduling is an open-loop adaptive control. Most of the time, characteristics of dynamic processes will change in different conditions, whose relation can be known. One reason of the change is nonlinear, and then parameters of controllers can be modified by monitoring operation conditions. Gain scheduling is an effective method in compensating known nonlinear[6-9].

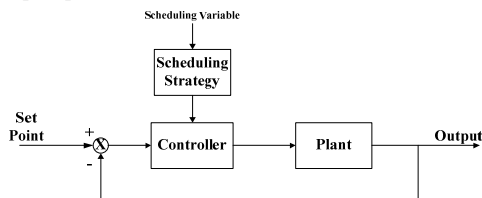

Fig. 1 Basic principle of gain scheduling control

PCCC describes coal quality, which can be used as scheduling variable. Thus gain scheduling can improve control quality obviously.

As mentioned above, coal quality disturbance brings about gain change of control system; hence gain scheduling can be used to modify proportional parameter of controller to reduce the disturbance.

In practical applications, the amount of feed water, fuel and unit load is in transitional state when units vary load, which has no sense for the calculation of PCCC. So, PCCC should be calculated during steady state of the unit, which can be judged as follows:

$$|N_e - N_0| < \lambda_1, T_1 > T;$$

$$|P_t - P_{t0}| < \lambda_2, T_2 > T;$$

where  $N_0$ ,  $P_{t0}$  denote set point of load and pressure respectively.  $T_1$ ,  $T_2$  denote duration.

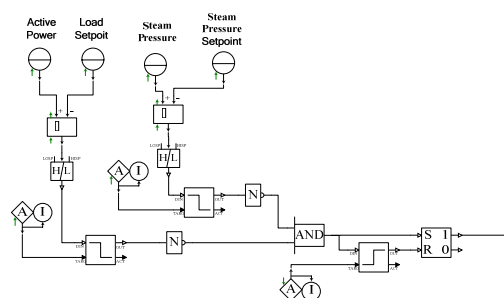

Fig. 2 Judgment of steady state operation

Besides that, gross coal consumption rate isn't from DCS system directly, which means error may occur during communication. As a function of coal consumption, PCCC may exist a great deviation. Hence it needs restriction and switch circuit to ensure control system's safety working. It can be configured as follows:

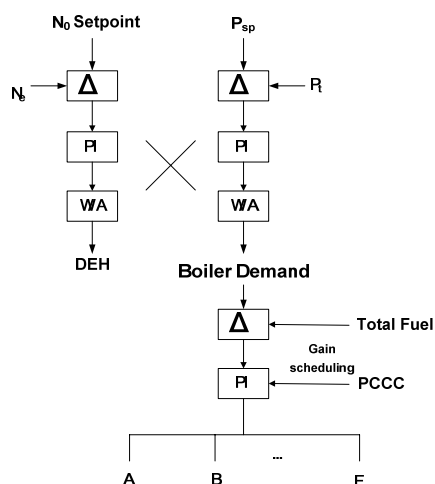

Fig. 3 The application of gain scheduling control for coordinate control system

#### IV. SIMULATION

The model described as equations 3-7 were used for simulation. Controller was designed as reference 10. PCCC was used as scheduling variable.

The controller was tuned at design parameters of the model. Range of controller's proportional parameter was limited from 120% to 80%, which could be calculated using Lagrange interpolation according to actual coal calorific value.

In order to verify the validity of the method, parameter  $K_1$  which represents coal quality was modified as figure 4 at 100 seconds.

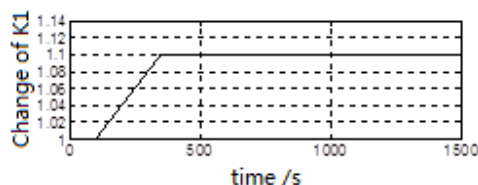

Fig. 4 Changing of the heat release of the coal

Performance of controller without gain scheduling and with gain scheduling was compared in figure 5 and 6.

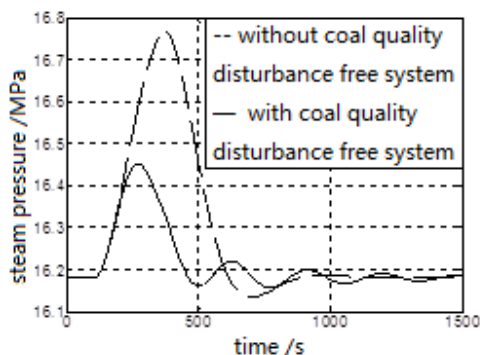

Fig. 5 Response of the main steam pressure

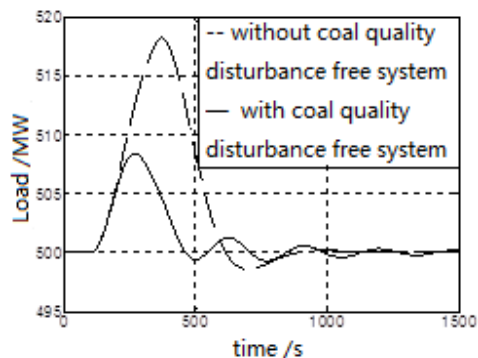

Fig. 6 Response of load

Two figures show the performances of the control system are improved with the help of gain scheduling. Table 1 gives the ITAE of gain scheduling and without gain scheduling.

TABLE.II  
 COMPARISON OF ITAE

	Without coal quality disturbance free system	With coal quality disturbance free system
ITAE-- steam pressure	6.2224e+4	3.3955e+4
ITAE-- load	1.9229e+6	1.0493e+6

The values of ITAE of control system with PCCC gain scheduling are always smaller, which means the performance of the system is improved.

#### V. CONCLUSION

Gain scheduling is an open-loop adaptive control algorithm, which is effective to compensate disturbance, if the disturbance can be known.

Based on the analysis of nonlinear model, coal calorific value can be seen as gain of system, and can be reflected by PCCC.

PCCC is validated by history data, and used as scheduling variable in designing gain scheduling control system. Simulation shows that, performance of the system is improved, and coal quality disturbance is inhibited.

#### REFERENCES

- [1] Guan Yue. The Study of the Effect of Coal Characteristics on the Economy of Power Plant[M], North China Electric Power University, 2006
- [2] Zhou MaoDe, Shi ZhanShan, Yu ZhiYuan. Effects and Policies of the Change of Coal Quality on Coal-fired Boiler. Shanxi Electric Power. 2005, 02, 9-11+19
- [3] Yang TingTing. Research on power saving optimization control of fossil plant based on data. North China Electric Power University, 2010
- [4] Zhao Zheng, Liu JiZhen, Tian Liang. Soft Measurement of Fuel Quantity Based on Data Fusion and On-line Calibration of Coal Heat Values. Journal of Engineering for Thermal Energy and Power, 2007,127, 42-45+60+109
- [5] Zeng DeLiang, Zhao Zheng, Chen YanQiao. A Practical 500mw Boiler Dynamic Model Analysis. Proceedings of the Csee, 2003,05
- [6] Huang ZhuYi. Gain Scheduled and Its Application on the Objects in Thermal System. Tsinghua University,2004
- [7] Fu CaiFen, Tan Wen, Liu JiZhen. Robust Gain Scheduling Controller

- Based on Loop Shaping. Information and Control,2005,02, 152-156+162
- [8] Huang ZuYi, Li DongHai, Jiang XueZhi. Gain Scheduled Servo System For Boiler-Turbine Unit. Proceedings of the Csee, 2003,10
- [9] Yu DanRen, Xu ZhiQiang, Weng YiWu. A New Understanding of DEB-Gain Scheduling Control. Journal Of Engineering For Thermal Energy And Power, 1999,05, 379-381+396-411
- [10] Xie Xie, Liu Jizhen, Zeng Deliang, Wen Tan. Research of Coordinated Control System Based on Robust Control. 2010 The 2<sup>nd</sup> International Conference on Computer and Automation Engineering, 2010,4,52-56