

Performance Analysis of Fuzzy Logic Based Unified Power Flow Controller

Lütfü Sarıbulut, Mehmet Tümay, and İlyas Eker

Abstract—FACTS devices are used to control the power flow, to increase the transmission capacity and to optimize the stability of the power system. One of the most widely used FACTS devices is Unified Power Flow Controller (UPFC). The controller used in the control mechanism has a significantly effects on controlling of the power flow and enhancing the system stability of UPFC. According to this, the capability of UPFC is observed by using different control mechanisms based on P, PI, PID and fuzzy logic controllers (FLC) in this study. FLC was developed by taking consideration of Takagi-Sugeno inference system in the decision process and Sugeno's weighted average method in the defuzzification process. Case studies with different operating conditions are applied to prove the ability of UPFC on controlling the power flow and the effectiveness of controllers on the performance of UPFC. PSCAD/EMTDC program is used to create the FLC and to simulate UPFC model.

Keywords—FACTS, Fuzzy Logic Controller, UPFC.

I. INTRODUCTION

THE growth of the power systems in the future will rely on increasing the capability of existing transmission systems rather than building the new transmission lines and the power stations for an economical and an environmental reasons. The requirement of the new power flow controllers, which is capable of increasing the transmission capability and controlling the power flow through the predefined corridors, will certainly increase due to the deregulation of the electricity markets. Additionally, these new controllers must be control the voltage levels and the flow of the real/reactive power in the transmission line to use full capability of the system in some cases with no reduction in the system stability and security margins [1]. A new technology concept known as Flexible Alternating Current Transmission Systems (FACTS) technology was presented in the late of 1980s [2]. FACTS devices enhance the stability of the power system with its fast control characteristics and continuous compensating

capability. The controlling of the power flow and increasing the transmission capacity of the existing transmission lines are the two main objectives of FACTS technology [3].

Thus, the utilization of the existing power system comes into optimal condition and the controllability of the power system is increased with these objectives. Gyugyi proposed the Unified Power Flow Controller which is the new type generation of FACTS devices in 1991 [4]. Unified Power Flow Controller (UPFC) is the member of FACTS device that has emerged for the controlling and the optimization of power flow in the electrical power transmission systems [5]. This device formed of the combination of two other FACTS devices namely as Static Synchronous Compensator (STATCOM) and the Static Synchronous Series Compensator (SSSC). These are connected to each other by a common DC link, which is a typical storage capacitor. The all parameters of the power transmission line (impedance, voltage and phase angle) can be control simultaneously by UPFC [6]. In addition, it can perform the control function of the transmission line real/reactive power flow, UPFC bus voltage and the shunt-reactive-power flow control [7].

The control mechanism and the controller have an important effect on the performance of UPFC. In the literature, several control mechanisms are used in UPFC models. A novel fuzzy inference system described in matrix form is proposed and used to improve the dynamic control of real and reactive power [8]. Two fuzzy logic controllers based on Mamdani type fuzzy logic are used. One of the controllers is proportional fuzzy logic controller (PF-UPFC) and the other is Hybrid fuzzy logic UPFC (HF-UPFC) [3]. The selection of suitable location for UPFC is studied and composite-criteria-based fuzzy logic is used to evaluate the network contingency ranking [9]. The power-feedback control scheme is used in the control mechanism of UPFC [10]. The power fluctuation is damped readily and the value of reactive power is minimized as possible by using several time constants. However there is no value changed in the real power. The control method of variable interval-fuzzy-mutual is used in the control mechanism of UPFC [11]. In the simulation results, there is a high overshoot values occurred both real power and bus voltage during the three phase faults applied. However, the real power value is increased but there is no value changed in the reactive power. The performance of UPFC is observed by using three different controllers [12]. In the simulation results, the variation of the real power direction can be observed

L. S. is with the Çukurova University, Department of Electrical & Electronics Engineering, Balcalı, Adana, Turkey (phone: 90-322-3386868/119; e-mail: lsaribulut@cu.edu.tr).

M. T. is with the Çukurova University, Department of Electrical & Electronics Engineering, Balcalı, Adana, Turkey (phone: 90-322-3386868/148; e-mail: mtumay@cu.edu.tr).

İ. E. is with the Çukurova University, Department of Electrical & Electronics Engineering, Balcalı, Adana, Turkey (phone: 90-322-3386868/135; e-mail: ilyas@cu.edu.tr).

easily. However, the value of reactive power is kept at zero because of there is no reactive power flow in the system. The performance of Pulse Width Modulation (PWM) based UPFC is observed [13]. According to results, the values of real and reactive power are changed in large values with UPFC because of the low values of bus voltage.

The capability of UPFC on controlling of the power flow and the effectiveness of controllers on performance of UPFC in the power transmission line are examined in two case studies by using different control mechanisms based on PI and fuzzy controllers in this paper. In the modeling of fuzzy controller, "Takagi-Sugeno Inference System" is used in the decision making process and "Weighted Average" method which is the special case of "Mamdani" model is used in the defuzzification process. The electromagnetic transient simulation program PSCAD/EMTDC is used to create UPFC model and to obtain the results of case studies [14].

II. UPFC SYSTEM

The UPFC is the combination of two voltage-source converters; one converter is connected to the power system through a shunt transformer, whereas the other converter is inserted into the transmission line through a series transformer [1]. The converters are connected by a common DC-link where the capacitor is coupled and it allows a bi-directional real power flow between the output terminal of shunt converter and the input terminals of series converter. The UPFC can be decoupled be into two branches according to its control and structure perspective. One of these branches is the parallel branch formed by the shunt transformer, VSC and DC capacitor. It operates as a STATCOM. The other is series branch composed of the series transformer, a VSC and DC capacitor. It behaves as a SSSC. The basic system configuration of UPFC structure is shown in Fig. 1.

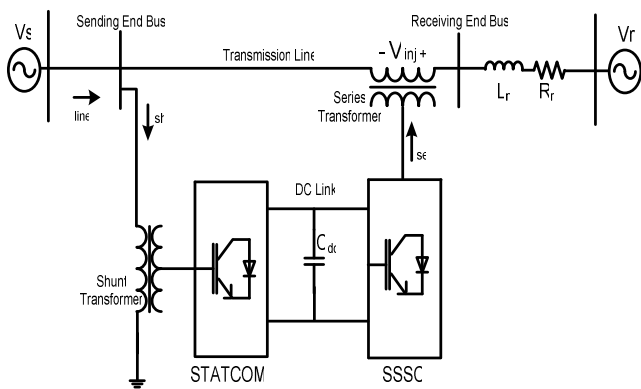

Fig. 1 Basic scheme of UPFC system

A. The Control Mechanism of Shunt Converter

The shunt converter is operated to draw a controlled current from the line. One component of this current is automatically determined as a requirement real power to meet the losses in the converters and to balance the real power of the series converter [15]. However, the net real power is used to maintain the dc voltage and to provide the reactive compensation without an external-electric-energy source to the system independently [16]. This component of current is calculated by finding the differences between reference value

(V_{dc}^*) and instant value (V_{dc}) of DC bus voltage in this study. The result is used as an angle σ in the sinus block of control mechanism. The other component is reactive part of current and it can be set to any desired reference level (inductive or capacitive) within the capability of the converter. This component is calculated in the same way with the other component by finding the differences between reference voltage (V_{sendpu}^*) and instant value of bus voltage (V_{sendpu}). The result is used as a magnitude (IVI_{pu}) to multiply with sinus block. The calculation of these two current components is shown in Fig. 2 and Fig. 3. Hence, the reference signals are calculated to use in the SPWM techniques. PI controller based and fuzzy controller based control mechanisms of shunt converter are given as separately in the following graphics.

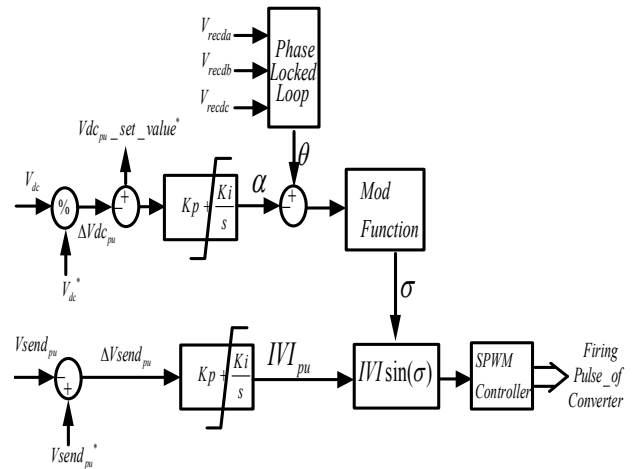

Fig. 2 PI controller based control mechanism

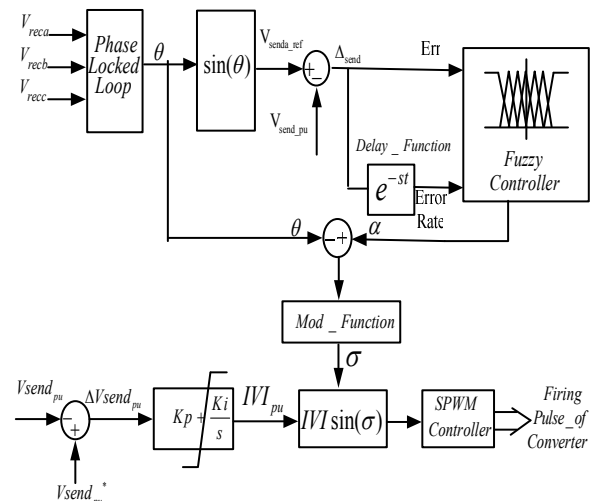

Fig. 3 Fuzzy controller based control mechanism

B. The Control Mechanism of Series Converter

The main function of UPFC is actualized by the series converter. It controls the magnitude and the angle of the voltage injected in series with the line. This voltage injection is always intended to influence the power flow the line [15]. The magnitude and the phase angle of series-injected voltage V_{inj} is calculated by control mechanism to provide the desired real and reactive power flow in the transmission line. In the

process of doing this, the series inverter will exchange real and reactive power with the line. The reactive power is electronically provided by the series inverter and the real power is transmitted to the dc terminals. The control mechanism of series converter is shown in Fig. 4. In the control mechanism, the receiving-end-generator voltage transforms into d_{q0} (Park) transform [17]. The d_{q0} components of receiving-end-voltage are multiplied with determined reference value of active/reactive powers (P_{ref}/Q_{ref}). Hence, the signals desired by user $\Delta V_{recD,Q,0}$ are calculated. Then, the phase angle (θ) of transmission line is obtained by using PLL (phase locked loop). It is used to calculate the reference signals V_{reca,b,c_ref} . These signals are transformed into d_{q0} form. The desired signals are subtracted from the reference signals and the results are transformed into three phase balanced system to use in the sinusoidal-pulse-width modulation (SPWM). Thus, the firing angles of IGBTs (insulated gate bipolar transistors) are produce from the process of SPWM technique.

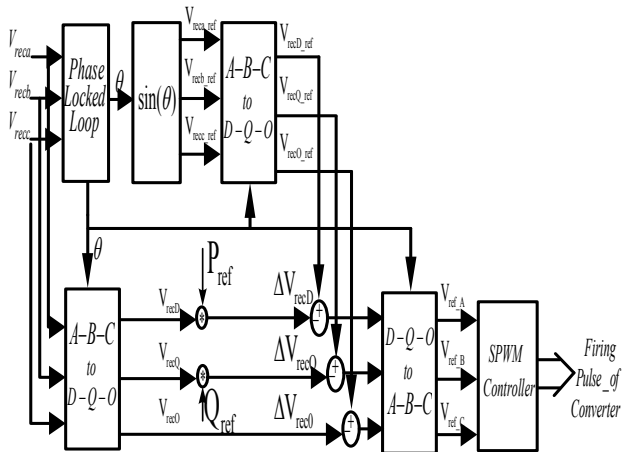

Fig. 4 Control mechanism of series converter

III. IMPLEMENTATION OF FLC IN UPFC

FLC are formed by simple rule based on “If x and y then z ”. These rules are defined by taking help from person’s experience and knowledge about the system behavior. The performance of the system is improved by the correct combinations of these rules. Each of the rules defines one membership which is the function of FLC. More sensitivity is provided in the control mechanism of FLC by increasing the numbers of membership functions [18]-[19]. In this study, the inputs of the fuzzy system are assigned by using 7 membership functions and the fuzzy system to be formed in 49 rules. Hence, the sensitivity in the control mechanism is increased. The fuzzy control system is divided into three main sections. These sections are explained in the following.

A. Error Calculation

The error signal (err_A) is calculated from the difference between the source voltage value and the reference value obtained from PLL. Beside, the error rate signal (Δerr_A) is the differences between the variation of error at current sampling and its previous sampling. These signals of supply voltage for

each phase are measured and converted into per unit (pu.) value. For phase A, the error and error rate are defined as:

$$err_A = V_{\sin(\theta),pu} - V_{send,pu} \quad (1)$$

$$\Delta err_A = err_A(n) - err_A(n-1) \quad (2)$$

where $V_{\sin(\theta),pu}$ is a PLL voltage possessed the same phase with the sending end voltage, $V_{send,pu}$ is the phase of sending end voltage and n is the sampling time.

B. FLC

The section of FLC is divided in three subsections. These subsections are given as summarized in the following:

Fuzzification: The numeric input-variable measurements are transformed by fuzzification part into the fuzzy linguistic variable, which is a clearly defined boundary with a crisp. These linguistic variables of error/error rate are shown in Fig. 5.

Decision Making: The fuzzy models are created by using “Sugeno Inference System” [20]. According to this system, the I_{th} rule can be calculated by using in the following equations:

$$L^{(1)} : \text{If } x_1 \text{ is } F_1^l \text{ and } \dots \text{and } x_n \text{ is } F_n^l, \text{ then} \quad (3)$$

$$y^l = c_0^l + c_1^l x_1 + c_2^l x_2 + \dots + c_n^l x_n \quad (4)$$

where F_1^l denotes fuzzy set, c_1^l is the real coefficients, y^l is the output set and $x_1 \dots x_2$ is the inputs.

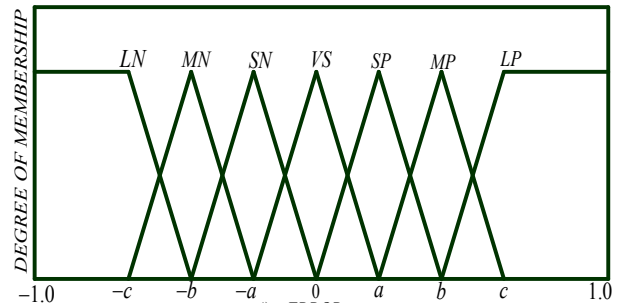

Fig. 5 Error and error rate of fuzzy membership functions

The basic if-then rule is defined as “If (error is very small and error rate is very small) then output”. The signals error and error rate are described as linguistic variables in the FLC such as large negative (LN), medium negative (MN), small negative (SN), very small (VS), small positive (SP), medium positive (MP) and large positive (LP). These are shown in Fig. 5. In the same way, the input values of the fuzzy controller are connected to the output values by the if-then rules. The relationship between the input and the output values can be achieved easily by using Takagi-Sugeno type inference method. The output values are characterized by memberships and named as linguistic variables such as negative big (NB), negative medium (NM), negative small (NS), zero (Z),

positive small (PS), positive medium (PM) and positive big (PB). The membership functions of output variables and the decision tables for FLC rules are seen in Table I.

TABLE I
FUZZY DECISION TABLE

Error rate /Error	LP	MP	SP	VS	SN	MN	LN
LP	PB ¹	PB ²	PB ³	PM ⁴	PM ⁵	PS ⁶	Z ⁷
MP	PB ⁸	PB ⁹	PM ¹⁰	PM ¹¹	PS ¹²	Z ¹³	NS ¹⁴
SP	PB ¹⁵	PM ¹⁶	PM ¹⁷	PS ¹⁸	Z ¹⁹	NS ²⁰	NM ²¹
VS	PM ²²	PM ²³	PS ²⁴	Z ²⁵	NS ²⁶	NM ²⁷	NM ²⁸
SN	PM ²⁹	PS ³⁰	Z ³¹	NS ³²	NM ³³	NM ³⁴	NB ³⁵
MN	PS ³⁶	Z ³⁷	NS ³⁸	NM ³⁹	NM ⁴⁰	NB ⁴¹	NB ⁴²
LN	Z ⁴³	NS ⁴⁴	NM ⁴⁵	NM ⁴⁶	NB ⁴⁷	NB ⁴⁸	NB ⁴⁹

Defuzzification: In the defuzzification process, the controller outputs represented as linguistic labels by a fuzzy set are converted to the real control (analog) signals. In the created fuzzy model, "Sugeno's Weighted Average" method which is the special case of "Mamdani Model" is selected for the defuzzification process [21]. According to this model, the defuzzification is achieved by using following equations:

$$y = \frac{\sum_{l=1}^M w^l y^l}{\sum_{l=1}^M w^l} \quad (5)$$

$$w^l = \prod_{i=1}^n M_{F_i^l}(x_i) \quad (6)$$

where w^l is the overall truth value of the rule $L^{(l)}$, $M_{F_i^l}(x_i)$ is the membership function described the meaning of the linguistic variable F_i^l .

C. Signal Processing

The control signals are produced from the output of FLC process. They are used in the generation of switching signals for converter by comparing with carrier signal. It can be shown in Fig. 2 and Fig. 3.

IV. CASE STUDIES

PSCAD/EMTDC program is used to simulate the modeling of UPFC and the test system. The parameters of simulated system are selected low ratings to be enabled the implementation of system in the laboratory environment. In the simulation case studies, two generators are used and named as sending end and receiving end generators, respectively. UPFC is constructed at the sending end bus before the line impedance. Two case studies were carried out to test the performance of UPFC with different control

mechanisms based on P, PI, PID and fuzzy logic controllers. The test system is shown in Fig. 6 and the parameters are given in the Appendix.

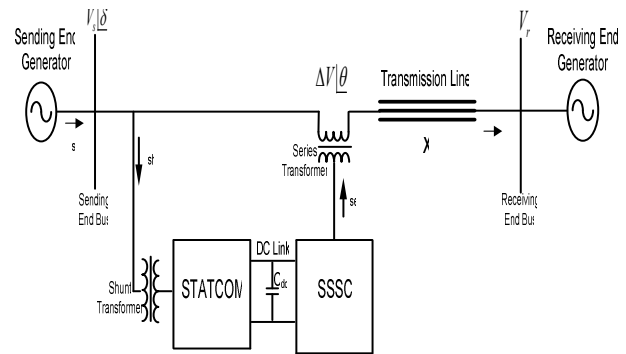

Fig. 6 Test system for case study 1

In the first case study, the receiving end generator is delayed from the sending end generator according to several phase angles. The values of the real/reactive power results in the line are taken by consideration of using the different controllers in the control mechanism separately and compared as with and without UPFC in the line. The results are given in Table II.

TABLE II
POWER FLOW OF THE LINE FOR PHASE VARIATION

Phase angle of receiving end generator (°)		60°	40°	30°	15°
		without UPFC	P(KW)	3.44	2.67
	Q(KVAR)	-1.4	-0.97	-0.72	-0.34
P Controller with UPFC	P(KW)	4.00	2.95	2.29	1.21
	Q(KVAR)	-0.62	-0.42	-0.37	-0.036
PI Controller with UPFC	P(KW)	4.14	3.09	2.43	1.37
	Q(KVAR)	-0.42	-0.15	-0.09	0.04
PID Controller with UPFC	P(KW)	4.15	3.06	2.40	1.35
	Q(KVAR)	-0.39	-0.21	0.14	0.01
FUZZY Controller with UPFC	P(KW)	4.33	3.14	3.14	1.41
	Q(KVAR)	-0.07	-0.08	-0.088	0.07

The test system for second case study is given in Fig. 7. In this case study, three transmission lines, which have same impedance parameters, are used and UPFC is constructed on transmission line 3 after the load. The reactive power and the bus voltage, the connection point which UPFC is connected to the line, are expected to be restored to their nominal values by UPFC. In the second case, the three phase fault is applied to the transmission line 1. It is started at the 1.4 sec and it is continued 0.2 sec. The fault is sensed by control mechanism of series converter, the electronic bypass is immediately activated to protect the series converter. The electronic bypass is removed by the control mechanism automatically after the fault. The PI and fuzzy controller's results values of reactive

power and bus voltage of receiving end are compared as graphically during the fault to be considered with and without UPFC in the line.

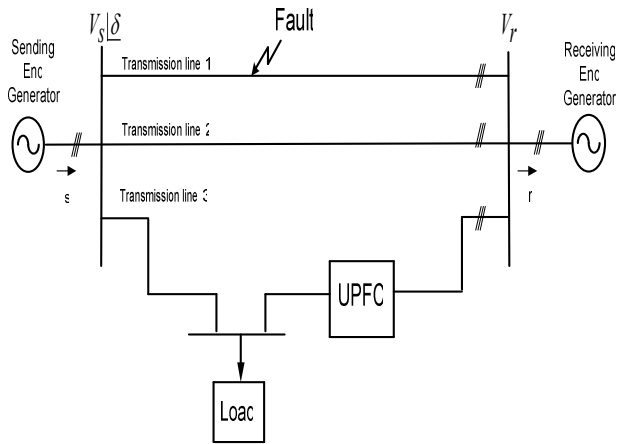

Fig. 7 Test system for case study 2

The variations on the receiving end reactive power (Q_{re}) and the receiving end voltage in pu. ($V_{pu, re}$) are illustrated as graphically in Fig. 8 and Fig. 9.

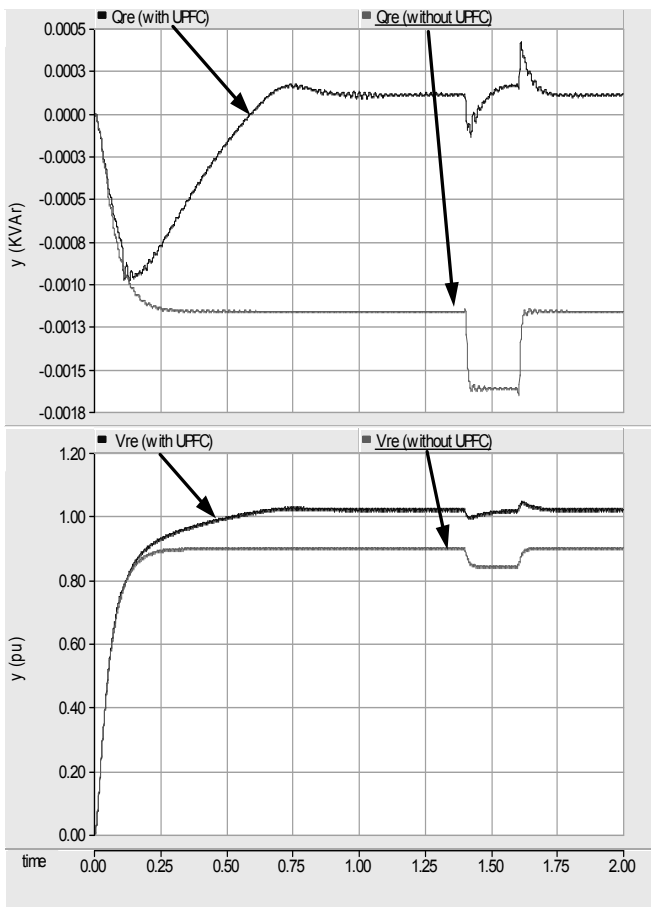

Fig. 8 PI controller results at fault condition

V. CONCLUSION

In this paper, the performance of UPFC on controlling of the real/reactive power flow in the line is examined with different control mechanisms based on P, PI, PID and fuzzy controllers. For the first case study, the results show that P controller does not sufficient on controlling the power flow while FLC shows the best performance on controlling the power flow. In the second case study, three phase fault is applied to the test system. The results are taken to be consideration of PI and fuzzy controllers because of the taken same results of these controllers in the first case study. The PI and fuzzy controllers show nearly same results but there is a low overshoot occurred during the fault in the fuzzy controllers results. According to results that UPFC improves the system performance under the transient and the normal conditions. However, it can control the power flow in the transmission line, effectively. Beside, the fuzzy controller based control mechanism showed better performance than P, PI, and PID controllers based control mechanisms. PSCAD/EMTDC program is used for modeling UPFC and taking the simulation results from the test system. In this study extent P, PID and fuzzy controllers are added as a new component in main library of PSCAD/EMTDC.

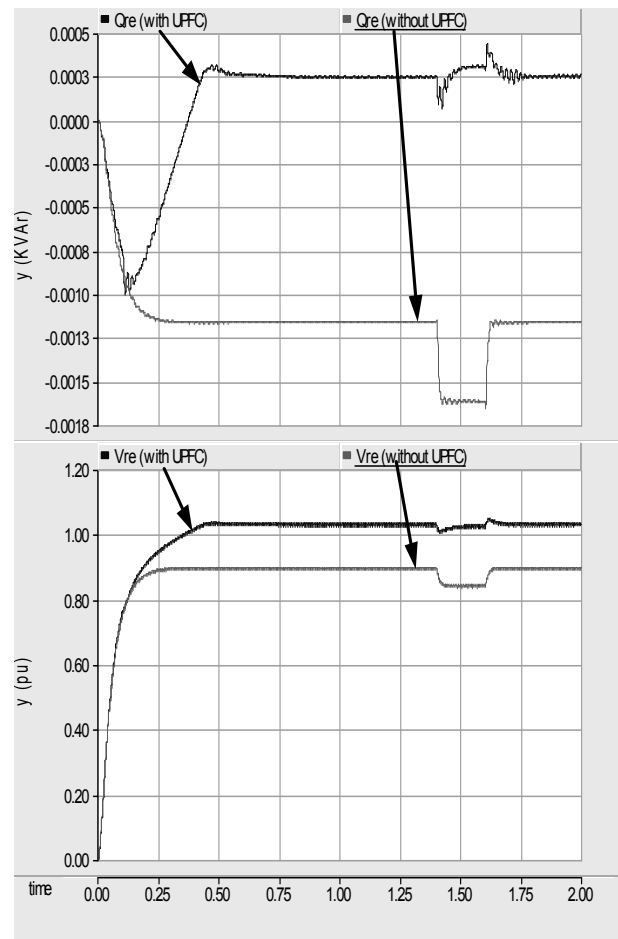

Fig. 9 Fuzzy controller results at fault condition

APPENDIX

The technical details of sending end and receiving end generators:

Based MVA (3-phase)	: 0.01 [MVA]
Base voltage (L-L)	: 0.380 [kV]
Base frequency	: 50.0 [Hz]
Phase	: 0.0 [°]

The technical details of shunt converter transformers:

Based MVA (3-phase)	: 0.003 [MVA]
Winding #1 voltage (L-L)	: 0.380 [kV]
Winding #2 voltage (L-L)	: 0.040 [kV]
Base operation frequency	: 50.0 [Hz]

The technical details of series converter transformers:

Based MVA (3-phase)	: 0.003 [MVA]
Winding #1 voltage (L-L)	: 0.110 [kV]
Winding #2 voltage (L-L)	: 0.110 [kV]
Base operation frequency	: 50.0 [Hz]

The system parameters:

V_{dc}	: 0.042 [kV]
C_{dc}	: 20 mF
R_r	: 4 Ω
L_r	: 10 mH

V_{dc} voltage controller PI parameters:

K_p	: 4.6
K_i	: 0.0001

Bus voltage controller PI parameters:

K_p	: 4.05
K_i	: 0.005

Fixed load parameters:

Rated real power per phase	: 0.002 [MW]
Rated reactive power per phase	: 0.001 [MVAR]
Rated load voltage (rms L-G)	: 0.380 [kV]
Fundamental Frequency	: 50 [Hz]

REFERENCES

[1] E. Uzunovic, C. A. Canizares, J. Reeve, "EMTP Studies of UPFC Power Oscillation Damping", North American Power Symposium (NAPS), San Luis Obispo, California, October 1999.

[2] Y. H. Song, A. T. Jons, "Flexible AC Transmission Systems (FACTS)", IEE Power and Energy Series 30, 1999.

[3] S. Hongbo, D.C Yu. Luo Chunlei, "A novel method of power flow analysis with unified power flow controller (UPFC)", Power Engineering Society Winter Meeting, 2000. IEEE Volume 4, 23-27 Jan. 2000 Page(s):2800 - 2805 vol.4 Digital Object Identifier 10.1109/PESW.2000.847327.

[4] Narain G. Hingorani, Laszlo Gyugyi "Understanding FACTS: Concepts and Technology of Flexible AC Transmission Systems", Power Electronics Sponsored By, 2000 by the institute of Electrical and Electronics Engineers, Inc. 3 Park Avenue, New York, NY 10016-5997.

[5] A. A. Eldamaty, S. O. Faried, S. Aboreshaid, "Damping Power System Oscillations Using a Fuzzy Logic Based Unified Power Flow Controller", Electrical and Computer Engineering, 2005, pp.:1950 – 1953.

[6] R.P Kalyani, G.K. Venayagamoorthy, M. Crow, "Neuroidentification of system parameters for the shunt & series branch control of UPFC", Power Engineering Society General Meeting, 2003, IEEE Volume 4, 13-17 July 2003 Page(s): Digital Object Identifier 10.1109/PES.2003.1271018.

[7] S. Kannan, S. Jayaram, M. M. A. Salama, "Real and Reactive Power Coordination for a Unified Power Flow Controller", IEEE Transactions on Power Systems, Volume 19, Issue 3, 2004, pp. 1454 – 1461.

[8] R. Orizondo, R. Alves, "UPFC Simulation and Control Using the ATP/EMTP and MATLAB/Simulink Programs", Transmission & Distribution Conference and Exposition, 2006, IEEE/PES, pp. 1 – 7.

[9] D. Thukaram, L. Jenkins, K. Visakha, "Improvement of System Security with Unified Power Flow Controller at Suitable Locations under Network Contingencies of Interconnected Systems", IEE Proceedings Generation, Transmission and Distribution, Vol. 152, Issue 5, 2005, pp. 682 – 690.

[10] H. Fujita, Y. Watanabe, H. Akagi, "Control and Analysis of a Unified Power Flow Controller", IEEE Transactions on Power Electronics, Volume 14, Issue 6, 1999, pp. 1021 – 1027.

[11] B. Lu, L. Hou, B. Li, Y. Liu, "A New Unified Power Flow Fuzzy Control Method", Innovative Computing, Information and Control, Second International Conference, 2007, pp. 479 – 479.

[12] Y. Qing, L. Norum, T. Undeland, S. Round, "Investigation of Dynamic Controllers for a Unified Power Flow Controller", Industrial Electronics, Control, and Instrumentation, Vol. 3, 1996, pp. 1764-1769.

[13] M. W. Mustafa, A. A. Zin, A.F. Kadir, "Steady State Analysis of Power Transmission Using Unified Power Flow Controller", Transmission and Distribution Conference and Exhibition, Vol. 3, pp. 2049 – 2053.

[14] Visual Power System Simulation, Web site available at <http://www.pscad.com>.

[15] C.D. Schauder, L. Gyugyi, M.R. Lund, D.M. Hamai, T.R. Rietman, D.R. Torgerson, A. Edris, "Operation of the unified power flow controller (UPFC) under practical constraints", Power Delivery, IEEE Transactions on Publication Date: Apr 1998 Volume: 13, Issue: 2 On page(s): 630-639 ISSN: 0885-8977.

[16] L. Liu, P. Zhu, Y. Kang, J. Chen, "Design and Dynamic Performance Analysis of a Unified Power Flow Controller", Industrial Electronics Society, 2005. IECON 2005. 31st Annual Conference of IEEE Publication Date: 6-10 Nov. 2005 On page(s): 6 pp. - ISBN: 0-7803-9252-3 INSPEC Accession Number: 8923352.

[17] S. Leva, A.P. Movando, "Park's equations for distributed constants line", Publication Date: 5-8 Sep 1999 Volume: 2, On page(s): 651-654 vol.2 Meeting Date: 09/05/1999 - 09/08/1999 Location: Pafos, Cyprus ISBN: 0-7803-5682-9 References Cited: 7.

[18] T. S. Chung, Y. Xiaodong, D. Z. Fang, C. Y. Chung, "Development of Adaptive UPFC Supplementary Fuzzy Controller for Power System Stability Enhancement", Electric Utility Deregulation, Restructuring and Power Technologies, Vol. 1, 2004, pp. 216 – 221.

[19] G. L. Sheng, W. Y. Lin, L. Sheng, "Research on Flexible Power Supply System for Arc Furnace Based on UPFC", Industrial Electronics and Applications, 2007, pp. 227-230.

[20] T. Takagi, M. Sugeno, "Fuzzy Identification of Systems and Its Applications to Modeling and Control". IEEE Transaction on Systems, Man and Sybern, Vol. 1985, pp. 1: 116-132.

[21] Timothy J. Ross, "Fuzzy Logic with engineering application", McGraw-Hill, Inc. 1995.