

# Numerical Analysis of Pressure Admission Angle to Vane Angle Ratios on Performance of a Vaned Type Novel Air Turbine

B.R. Singh and O. Singh

**Abstract**—Worldwide conventional resources of fossil fuel are depleting very fast due to large scale increase in use of transport vehicles every year, therefore consumption rate of oil in transport sector alone has gone very high. In view of this, the major thrust has now been laid upon the search of alternative energy source and also for cost effective energy conversion system. The air converted into compressed form by non conventional or conventional methods can be utilized as potential working fluid for producing shaft work in the air turbine and thus offering the capability of being a zero pollution energy source. This paper deals with the mathematical modeling and performance evaluation of a small capacity compressed air driven vaned type novel air turbine. Effect of expansion action and steady flow work in the air turbine at high admission air pressure of 6 bar, for varying injection to vane angles ratios 0.2-1.6, at the interval of 0.2 and at different vane angles such as 30°, 45°, 51.4°, 60°, 72°, 90°, and 120° for 12, 8, 7, 6, 5, 4 and 3 vanes respectively at speed of rotation 2500 rpm, has been quantified and analyzed here. Study shows that the expansion power has major contribution to total power, whereas the contribution of flow work output has been found varying only up to 19.4%. It is also concluded that for variation of injection to vane angle ratios from 0.2 to 1.2, the optimal power output is seen at vane angle 90° (4 vanes) and for 1.4 to 1.6 ratios, the optimal total power is observed at vane angle 72° (5 vanes). Thus in the vaned type novel air turbine the optimum shaft power output is developed when rotor contains 4-5 vanes for almost all situations of injection to vane angle ratios from 0.2 to 1.6.

**Keywords**—zero pollution, compressed air, air turbine, vane angle, injection to vane angle ratios

## I. INTRODUCTION

THE consumption pattern of hydrocarbon fuel and its implications upon the environment and ecology have made it inevitable to search for environment friendly alternative to oil globally. Marion King Hubbert a noted US based Geologist in 1956 predicted that most of the country may reach to peak oil day within 20 years and thereafter depletion of hydrocarbon fuel may cause serious threat within

Prof. B. R. Singh is Head of Department - Mechanical Engineering with SMS Institute of Technology, Lucknow-227125, Uttar-Pradesh, INDIA (phone: +91-522-223-8116, +91-522-272-5825; fax: +91-522-223-7273; e-mail: brsinghko@rediffmail.com).

Prof. O. Singh is Head of Department - Mechanical Engineering with Harcourt Butler Technological Institute, Kanpur-208002, Uttar-Pradesh, INDIA. (e-mail: onkpar@rediffmail.com).

40 years apart from releasing huge amount of pollutant in the environment [1]. Aleklett and Campbell during their study shown that with the current rate of consumption, 80 per cent of globally available resources of fossil fuel would be exhausted by 2020 [2]. This apprehension necessitates the search for environment friendly alternative to fossil fuel oil or some method of conserving natural resources using non-conventional options, such as bio diesel, wind power, biomass etc. and some other options like conversion of energy such as battery, hydrogen cell, photovoltaic cells and compressed air etc. to generate shaft work for running the engines of light vehicles [3-9].

Such alternatives ideally should have nearly zero or minimal pollution level. It should also have low initial cost, low running expenses, high degree of reliability, convenience, and versatility of use. The non conventional energy source like wind, hydraulic and or sun energy can be utilized to compress the air. Use of compressed air for running prime mover like air turbine offers a potential solution to these issues. Pioneering work in the area of compressed air engine has been done by French technologist Guy Negre [10] and also by an inventor of quasi turbine G. Saint Hilaire [11]. These highly compressed air energy storage systems can be filled up to 20 bar pressure within 15–20minutes, and reused for running compressed air engines. In view of these attractive features, the compressed air engine may remain the dominant technology in place of the electric and hydrogen cell vehicle markets.

The numerical analysis of a small capacity air turbine with vane type rotor has been carried out and presented in this paper with specific reference to investigating the effect of variation of injection to vane angle ratios with respect to change in vane angles( number of vanes). Results obtained using the mathematical modeling are presented and analyzed here.

## II. SCOPE OF COMPRESSED AIR ENGINE

In any developing country like India the average income per person to meet livelihood requirements is very low. The majority of the population of the country still lives in rural and suburban areas where the means of transport is either bicycle or motorbike. The continuous hikes of fossil fuel prices at the rate of around 20–30 per cent every year are making the situation miserable. Extrapolation shows that at this rate, by 2010-12, prices may be double as what they were in 2005, and

by 2030–40, may touch Rs. 1000 per litre. A time will come when the common person will not be able to purchase fuel to run motorbikes. This is not only due to the high demand for vehicles or its increasing numbers worldwide, but also due to the cost of fossil fuel going high as 80 per cent of the available fossil fuel is presently being consumed in transport. Thus, it is imperative to explore the possibility of alternatives to fossil fuel to make the environment free from emission for keeping the present and future generations healthy. For the last two decades, much research has been done to tap the air freely available in the atmosphere and to compress it for storage in cylinders for further use. Apart from other uses of compressed air, this can also be used to run combustion engines with the mixture of gas and air getting fired after the compression stroke at top dead centre. The use of compressed air will eliminate the need of having a separate compression stroke. Compressed air helps in the attainment of the expansion stroke after ignition takes place. Thus, the efficiency of the internal combustion engine is improved, and without running all four stroke cycles, it runs on two stroke cycles. The air engines developed so far are basically running on hybrid systems [10, 11] such as compressed air and gases, and are not 100 per cent pollution less.

#### A. Availability of Air

Air is a natural resource available freely in the atmosphere. Air can be suitably stored after being compressed to desired pressures such as 6–20 bar without any change in its property. In fact, it is one working fluid that can be stored at very high pressure and can be retained without any loss after lapse of time. Compressed air can drive many domestic appliances such as vacuum cleaners, mixers, pumps, or electric generators when electric power fails, instead of using inverters to having clumsy battery arrangements, etc.

#### B. Influence on environment and ecology

All Modern light vehicles running on fossil fuel release tail pipe emissions hazardous to public health. These emissions contribute significantly to creating ecological imbalances. Compressed air as an alternative for running light vehicles using air turbines has practically least harmful effect on the environment and thus has less health hazards.

#### C. Sustainability, advantages, and economics

Compressed air is most sustainable due to the absence of volatility and the effects of temperature or other weather factors. Compressed air once stored after compression is available at any time without any loss of pressure. Thus, sustainability of compressed air is much better when compared with other available options. Windmills [4] running on atmospheric air have attractive features due to the use of air as a working fluid, but have limitations due to the requirement of certain storage devices such as high bank capacitors or batteries, which will need constant and recurring expenditures for their upkeep. In case compressed air is being used in place of fossil fuel, the air is freely available in the atmosphere and offers zero cost of basic working fluid, and the cost involvement in its compression is also nominal. The

costing analysis for the vaned air turbine-based engine under study is as detailed here.

- Cost of 7.5–10kW electric motor coupled with two to three stage compressors: Rs. 25 000
- Cost of electricity for filling the compressed air cylinder once\*: Rs. 5 to 7

\*Consumption of electric power for running it for 5–10min\*\* to fill a cylinder 1.2m long with 0.65m diameter at 15–20 bar (225–300 lbf/in<sup>2</sup>) may cost {(10 kWh × Rs. 4# to 5#) (\*\*8min average / 60min) = Re. 5 to 7} including depreciation, running, and maintenance of compressor devices.

#Cost of electricity per unit in Rupees  
 \*\*8min, average

- Once filled, compressed air cylinder can run vehicle up to: 40 km
- Cost of running vehicle per km using compressed air: Re. 0.12 to 0.17
- Present cost of running vehicle per km sing hydrocarbon fuel: Re. 0.62 to 0.75

This shows that the motorbike may run 40 km on Rs. 5 to 7, whereas the cost for the same distance travelled with hydrocarbon fuel may be around Rs. 25 to 30; hence, the cost of using compressed air is almost one-fifth of the fossil fuel cost. Also in the absence of fossil fuel combustion, air as a working fluid offers the advantage of giving zero pollution engines. Thus, the use of compressed air is environmentally friendly apart from being economical.

### III. MODEL OF NOVEL AIR TURBINE

In this study a vaned type air turbine is proposed as shown in Figures 1a and 1b. The proposed air turbine is considered to work on the reverse working principle of vane type compressor. In this arrangement total shaft work is cumulative effect of isobaric admission of compressed air jet on vanes and the adiabatic expansion of high pressure air.

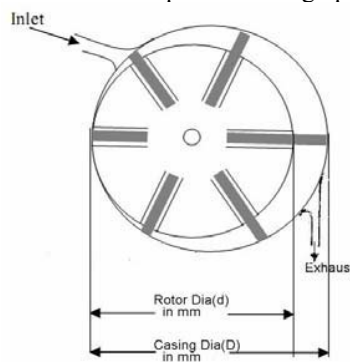

Fig. 1a Air Turbine-Diagram

In earlier study conducted by authors a prototype of air turbine was developed and its functionality was ensured [12]. A cylinder for the storage of compressed air with a minimum capacity of storing air for the requirement of 30 minutes running at initial stage and maximum pressure of 20 bar is used as a source of compressed air. The compressed air storage cylinder is designed to produce constant pressure for the minimum variation of torque at low volumes of

compressed air and attached with filter, regulator and lubricator which regulate and maintain the constant pressure. The clean air then admits into air turbine through inlet passage / nozzle. Vanes of novel air turbine are placed under spring loading to maintain their regular contact with the casing wall to minimize leakage which is proposed as improvement over the currently available vane turbine. The various parameters of air and other turbines are also studied for optimizing shaft output [13- 21].

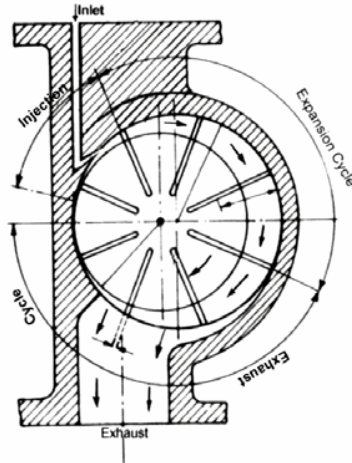

Fig. 1b Air Turbine- Model

The present objective is to investigate the performance of an air turbine with the variation of injection angle, i.e. at which angle air should admit into the turbine between first two consecutive vanes. The air turbine considered has capability to yield output of 4.0 to 5.5 kW at 4-6 bar air pressure and for speed of 2000–2500 rpm, which is suitable for a motorbike.

#### IV. MATHEMATICAL MODELING

The high pressure jet of air at ambient temperature drives the rotor in novel air turbine due to both isobaric admission and adiabatic expansion. Such high pressure air when enters through the inlet passage, pushes the vane for producing rotational movement through this vane and thereafter air so collected between two consecutive vanes of the rotor is gradually expanded up to exit passage. This isobaric admission and adiabatic expansion of high pressure air both contribute in producing the shaft work from air turbine. Compressed air leaving the air turbine after expansion is sent out from the exit passage. It is assumed that the scavenging of the rotor is perfect and the work involved in recompression of the residual air is absent as seen from Figure 1b. Similar type of mathematical modeling has been done by authors in earlier studies and reproduced here for benefits of the readers.

From Figure 2, it is seen that work output is due to isobaric admission (E to 1), and adiabatic expansion (1 to 4) and reference points 2, 3 in the figure shows the intermediate position of vanes. Thus, total work output due to thermodynamic process may be written as:

[Area under (E145CE)] = [Area under (E1BOE)] + Area under (14AB1) – Area under (4AOD4) + Exit steady flow (45CD4)] or

Total work output = [Thermodynamic expansion work ( $w_1$ )] + [Exit steady flow work ( $w_2$ )]

$$\text{or } w = [(w_1) + (w_2)] \quad (1)$$

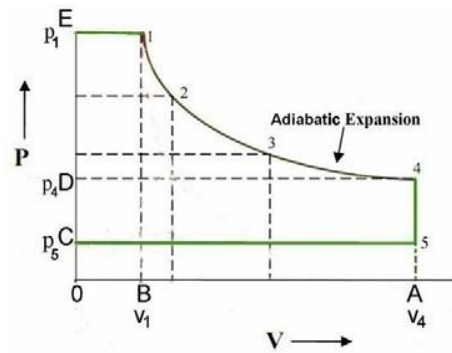

Fig. 2 Thermodynamic Processes (Isobaric, adiabatic and Isochoric Expansion)

Now thermodynamic expansion work ( $w_1$ ), can be written as:

$$w_1 = p_1 \cdot v_1 + \left( \frac{p_1 \cdot v_1 - p_4 \cdot v_4}{\gamma - 1} \right) - p_4 \cdot v_4$$

$$\text{or } w_1 = \left( \frac{\gamma}{\gamma - 1} \right) (p_1 \cdot v_1 - p_4 \cdot v_4)$$

For adiabatic process,  $p \cdot v^\gamma = p_1 \cdot v_1^\gamma = p_4 \cdot v_4^\gamma = \text{constant}$

$$\text{or } v_4 = \left( \frac{p_1}{p_4} \right)^{\frac{1}{\gamma}} \cdot v_1$$

Thus thermodynamic expansion work output would be:

$$w_1 = \left( \frac{\gamma}{\gamma - 1} \right) \cdot p_1 \cdot v_1 \cdot \left\{ 1 - \left( \frac{p_4}{p_1} \right)^{\frac{\gamma - 1}{\gamma}} \right\} \quad (2)$$

The process of exit flow (4-5) takes place after the expansion process (E- 4) as shown in Fig. 3 and air is released to the atmosphere. In this process; till no over expansion takes place pressure  $p_4$  can't fall below atmospheric pressure  $p_5$ . Thus at constant volume when pressure  $p_4$  drops to exit pressure  $p_5$ , no physical work is seen. Since turbine is functioning as positive displacement machine and hence under steady fluid flow at the exit of the turbine, the potential work is absorbed by the rotor and flow work ( $w_2$ ), can be written as:

$$w_2 = \int_4^5 v \cdot dp = v_4 (p_4 - p_5) \quad (3)$$

Applying equations (2), (3) into equation (1), therefore net work output will be:

$$w = (w_1 + w_2) = \left(\frac{\gamma}{\gamma-1}\right) \cdot p_1 \cdot v_1 \cdot \left\{1 - \left(\frac{p_4}{p_1}\right)^{\frac{\gamma-1}{\gamma}}\right\} + (p_4 - p_5) \cdot v_4 \quad (4)$$

When air turbine is having  $n$  number of vanes, then shaft output [22] can be written as:

$$w_n = n \cdot \left(\frac{\gamma}{\gamma-1}\right) \cdot p_1 \cdot v_1 \cdot \left\{1 - \left(\frac{p_4}{p_1}\right)^{\frac{\gamma-1}{\gamma}}\right\} + n \cdot (p_4 - p_5) \cdot v_4 \quad (5)$$

Where  $w_n$  is work output (in Nm), for complete one cycle.

Therefore, the total power output or work done per unit time ( $W_{total}$ ), for speed of rotation  $N$  rpm, will be mentioned as:

$$W_{total} = n \cdot (N/60) \cdot \left(\frac{\gamma}{\gamma-1}\right) \cdot p_1 \cdot v_1 \cdot \left\{1 - \left(\frac{p_4}{p_1}\right)^{\frac{\gamma-1}{\gamma}}\right\} + n \cdot (N/60) \cdot (p_4 - p_5) \cdot v_4 \quad (6)$$

Where  $W_{exp} = n \cdot (N/60) \cdot \left(\frac{\gamma}{\gamma-1}\right) \cdot p_1 \cdot v_1 \cdot \left\{1 - \left(\frac{p_4}{p_1}\right)^{\frac{\gamma-1}{\gamma}}\right\}$

and  $W_{flow} = n \cdot (N/60) \cdot (p_4 - p_5) \cdot v_4$

Figure 1a shows that if vanes are at angular spacing of  $\theta$  degree, then total number of vanes will be  $n = (360/\theta)$ . The variation in volume during expansion from inlet to exit (i.e.  $v_1$  to  $v_4$ ) can be derived by the variable extended length of vane as shown in Figure 3 at every point of movement between two consecutive vanes.

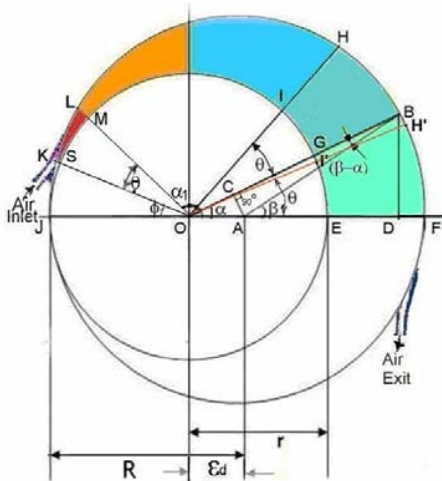

Fig. 3 Variable length BG and IH and injection angle  $\phi$

From Figure 3, it is seen that when two consecutive vanes at OK and OL moves to position OH and OB, the extended vane lengths varies from SK to IH and LM to BG, thus the variable length BG at variable  $\alpha_i$  is assumed as  $X_{at\ variable\ \alpha}$  can be written from the geometry

$$BG = X_{at\ variable\ \alpha} = R \cos \left[ \sin^{-1} \left\{ \left( \frac{R-r}{R} \right) \cdot \sin \alpha \right\} \right] + (R-r) \cdot \cos \alpha - r \quad (7)$$

where  $2R=D$  is diameter of casing and  $2r=d$  is diameter of rotor,  $\alpha$  is angle  $\angle BOF$ ,  $\beta$  is angle  $\angle BAF$  and  $\theta$  is angle  $\angle HOB$  or  $\angle H'OF$  or  $\angle KOL$ , between two consecutive vanes and  $\phi$  is angle  $\angle KOJ$  at which injection pressure admits to the air turbine.

Variable volume of cuboids' B-G-I-H-B can be written as:

$$v_{cuboids} = L \cdot \left\{ \frac{(X_{1i} + X_{2i})(2r + X_{1i})}{4} \right\} \cdot \sin \theta \quad (8)$$

Where  $BG = X_{1i}$  and  $IH = X_{2i}$  variable length of vanes when rotate into turbine as shown in Figure 3. The lengths (IG, HB and LK, SM), are considered linear whereas all are chords of circles. This approximation is done in mathematical model which has very least impact on the over all values.

The volume at inlet  $v_1$  or  $v_{min}$  will fall between angle  $\angle LOF = \alpha_{1min} = (180 - \theta - \phi)$  and

angle  $\angle KOF = \alpha_{2min} = (\alpha_{1min} + \theta) = (180 - \phi)$  as seen in Figure 3, when air is admits into turbine at angle  $\phi$ .

Applying above conditions into equations (7), then  $LM = X_{1min}$  and  $SK = X_{2min}$  can be written as:

$$X_{1min} = R \cos \left[ \sin^{-1} \left\{ \left( \frac{R-r}{R} \right) \cdot \sin(180 - \theta - \phi) \right\} \right] + [(R-r) \cdot \cos(180 - \theta - \phi) - r] \quad (9)$$

$$X_{2min} = R \cos \left[ \sin^{-1} \left\{ \left( \frac{R-r}{R} \right) \cdot \sin(180 - \phi) \right\} \right] + [(R-r) \cdot \cos(180 - \phi) - r] \quad (10)$$

Applying values of  $X_{1min}$  and  $X_{2min}$  to equation (8),

$$v_1 = v_{min} = L \cdot \left\{ \frac{(X_{1min} + X_{2min})(2r + X_{1min})}{4} \right\} \cdot \sin \theta \quad (11)$$

The Volume at exit  $v_4$  or  $v_{max}$  will fall between angle  $\angle BOF \quad \alpha_{1max} = \alpha = 0$  and angle  $\angle HOF$

$$\alpha_{2max} = (\alpha_{1max} + \theta) = \theta$$

Applying above conditions into equations (7), then  $FE = X_{1max}$  = Corresponding to BG at  $\alpha = 0$  degree and  $I'H' = X_{2max}$  = Corresponding IH at  $(\alpha + \theta) = \theta$  degree can be written as:

$$X_{1max} = (D - d) = 2(R - r) \quad (12)$$

$$X_{2max} = R \cos \left[ \sin^{-1} \left\{ \left( \frac{R-r}{R} \right) \cdot \sin \theta \right\} \right] + \{(R-r) \cdot \cos \theta\} - r \quad (13)$$

Applying values of  $X_{1max}$  and  $X_{2max}$  to equation (8),

$$v_4 = v_{max} = L \cdot \left\{ \frac{(X_{1max} + X_{2max})(2r + X_{1max})}{4} \right\} \cdot \sin \theta \quad (14)$$

Applying values of  $v_1$  and  $v_4$  from equations (11) and (14) to equation (6), the total power output available  $W_{total}$  can be written as:

$$W_{total} = n(N/60) \cdot \left( \frac{\gamma}{\gamma-1} \right) \cdot \left[ 1 - \left( \frac{P_4}{P_1} \right)^{\frac{\gamma-1}{\gamma}} \right] \cdot P_1 \cdot \left[ L \cdot \left\{ \frac{(X_{1min} + X_{2min}) \cdot (2r + X_{1min})}{4} \right\} \cdot \sin \theta \right] \quad (15)$$

$$+ n(N/60) \cdot (P_4 - P_5) \cdot \left[ L \cdot \left\{ \frac{(X_{1max} + X_{2max}) \cdot (2r + X_{1max})}{4} \right\} \cdot \sin \theta \right]$$

### V. INPUT PARAMETERS

Detailed analysis to derive relation between injection angle to vane angle for optimizing power output has been carried out in earlier studies by authors in respect to variation in expansion, flow work, percentage contribution of expansion and flow and total works at admission pressure of 6 bar and speed of rotation of 2500 rpm. It was found that the contribution of expansion work and total power output becomes considerably large at vane angle 90° (4 vanes) when injection angles are kept 10°-60° and it becomes optimum at vane angle 60° (6 vanes) when injection angles are kept 70°-80° and optimum value may further shift to vane angle 45° (8 vanes) when injection angle may be kept 90° or more. Thus vane angle should be kept between 45°-90° (8-4 vanes), because of following reasons:

- More vanes in air turbine develops more friction and it reduces the output
- Vane turbine having fewer vanes gives larger volumes between 2-consecutive vanes and gives rise to more space for expansion and ultimately increases the power output.

In this study the vane angle of air turbine is considered 30°, 45°, 51.4°, 60°, 72°, 90° and 120° (i.e. 12, 8, 7, 6, 5, 4 and 3 vanes respectively) and ( $\phi / \theta$ ) ratios 0.2, 0.4, 0.6, 0.8, 1.0, 1.2, 1.4 and 1.6. Other various input parameters are listed in Table 1 for investigation of different air injection to vane angle ratios and its optimization for larger shaft output.

TABLE I  
 INPUT PARAMETERS

Symbols	Parameters
$R = (D / 2)$	150mm (outer Casing)
$r = (d / 2)$	100mm (inner Rotor)
$P_1$	6bar (=90 psi)
$P_5$	1 atm = 1.0132 bar
$P_4$	(1.1=1.2) $P_5 = 1.1$ bar
$N$	500 rpm, 1500 rpm, 2500 rpm
$n$	Number of vanes = (360 / $\theta$ )
$L$	35mm length of rotor
$\gamma$	1.4 for air
$\theta$	30°, 45°, 51.4°, 60°, 72°, 90° and 120° (i.e. rotor contains 12, 8, 7, 6, 5, 4 and 3 numbers of vanes respectively)
$\left( \frac{\phi}{\theta} \right)$ ratio	0.2, 0.4, 0.6, 0.8, 1.0, 1.2, 1.4 and 1.6

### VI. RESULTS AND DISCUSSION

Based on the various input parameters listed in Table-1 and its application to the mathematical model, the effects of different injection to vane angles ratio with respect to different vanes in the turbine, expansion work, exit flow work and total work output from air turbine are studied. Here the injection pressure and speed of rotation of the air turbine are considered to be constant at 6 bar and 2500 rpm for whole study. The results obtained have been plotted in Figures (4) to (8).

Figure 4 shows the variation of expansion work at different vane angles with respect to injection angle / vane angle ratios at air injection pressure of 6 bar and speed of rotation 2500 rpm. It is evident that the shaft power output due to expansion ( $W_{exp}$ ) is low at vane angle 30° and thereafter it gradually increases with increase in vane angles from 45° to 90°. For injection to vane angle ratios 0.2-1.2 and thereafter it decreases rapidly from 90°-120° and hence optimum power output is seen at all conditions at vane angle 90° (4 vanes). Similar variations of expansion power are also obtained for injection to vane angle ratios 1.4-1.6 but optimum power output appears at vane angle 72° (5 vanes). It is also seen that expansion power is small at lower speed of rotation 500 rpm and 1500rpm for all injection angle and injection pressure (Figs. are not shown here).

Figure 5 shows the percentage contribution of expansion power to total power output at different vane angles with respect to injection angle to vane angle ratios at air injection pressure of 6 bar and speed of rotation 2500 rpm. It is observed that percentage contribution of expansion power is 80.6% as a lowest value, when vane angle is kept at 30° (12 vanes) and the injection to vane angle ratio is 0.2. The expansion contribution increases up to 96.2% when vane angle is varying from 45° to 120° (8-3 vanes). Similarly contribution of expansion is found higher from 85.7% to 96.2%, when injection / vane angle ratio is varying from 0.4 - 1.4, and vane angle varying from 45° to 120° (8 - 3 vanes).

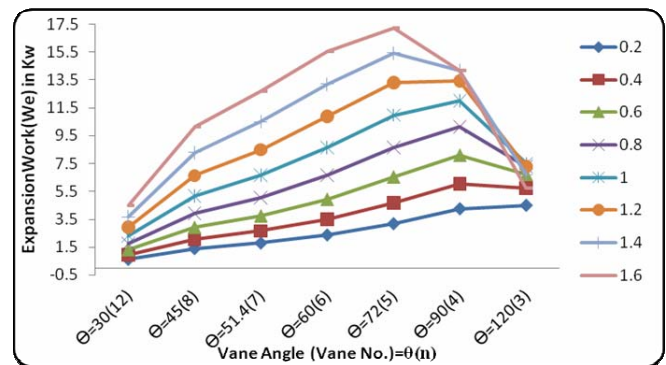

Fig. 4 Expansion Power Output vs. Vane angle at different Injection to Vane angles ratio, Injection pressure 6 bar and Speed of Rotation 2500 rpm

It also signifies that the expansion power contribution is found minimum for the injection to vane angle ratio of 0.2 and gradually increases as the vane angle increases from 45° to 120°. Similarly percentage contribution of expansion work is found to follow same trend at different speeds of rotation 500 rpm and 1500 rpm (Figs. are not shown here).

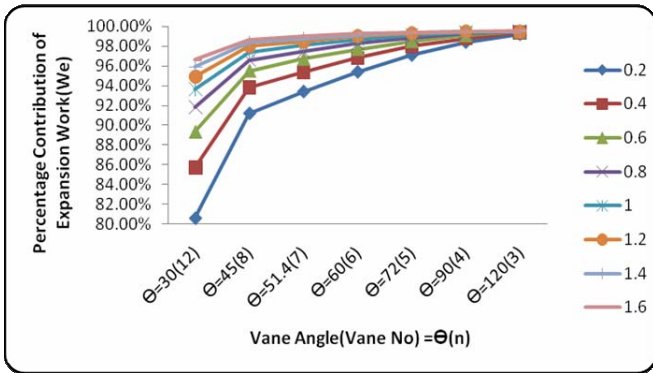

Fig. 5 Percentage contribution of Expansion Power vs Vane angle at different Injection to Vane angles ratio, Injection pressure 6 bar and Speed of Rotation 2500 rpm

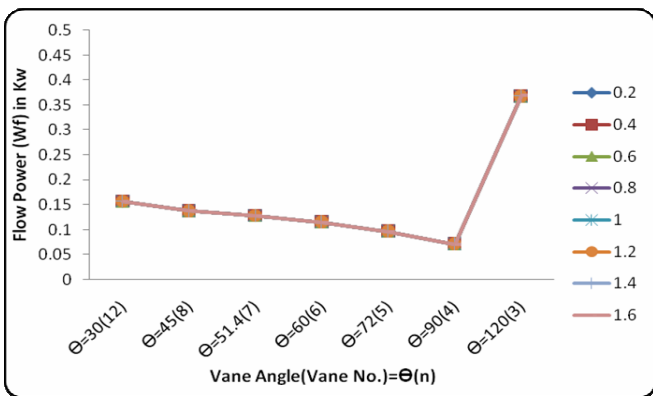

Fig. 6 Flow Power output vs. Vane angle at different Injection to Vane angles ratio, Injection pressure 6 bar and Speed of Rotation 2500 rpm

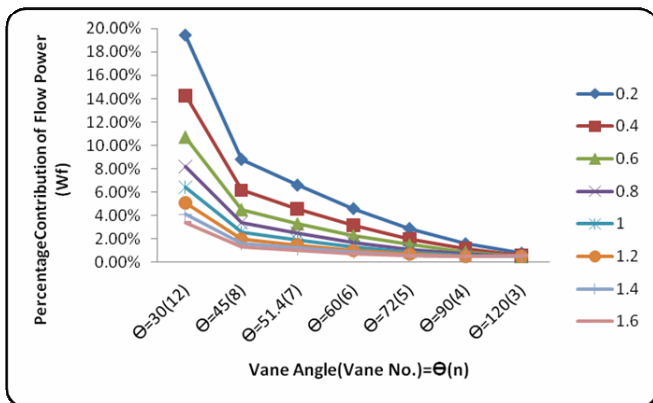

Fig. 7 Percentage contribution of Flow Power vs Vane angle at different Injection / Vane angles ratio, Injection pressure 6 bar and Speed of Rotation 2500 rpm

Figure 6 shows the exit flow action at different vane angles with respect to injection angle to vane angle ratios at air injection pressure of 6 bar and speed of rotation 2500 rpm. It is evident that the exit flow power ( $W_{flow}$ ) at injection to vane angle ratio 0.2 is found to the order of 0.1556 kW at vane angle 30° and thereafter it gradually decreases with increase in vane angles from 45° to 90° up to 0.0707 kW and rapidly gets increased 0.3687 kW at vane angle 120°. Similar exit flow power is developed for injection to vane angle ratios

from 0.4-1.4. The shaft power due to exit flow is found further small at low speed of rotation 500rpm and slightly higher at 1500 rpm (Figs. are not shown here).

Figures 7 shows the percentage contribution of exit flow power to total power output at different vane angles with respect to injection angle to vane angle ratios at air injection pressure of 6 bar and speed of rotation 2500 rpm. It is evident that percentage contribution due to exit flow power follow exactly reversed value to the percentage contribution of expansion but contribution at injection to vane angle ratio 0.2 and vane angle 30° is found 19.4% and thereafter it reduces to 0.6% for injection to vane angle ratios from 0.4-1.4 and vane angle 60° - 120°. Similarly percentage contribution of exit flow power is found to follow same trend at different speeds of rotation 500 rpm and 1500 rpm (Figs. are not shown here).

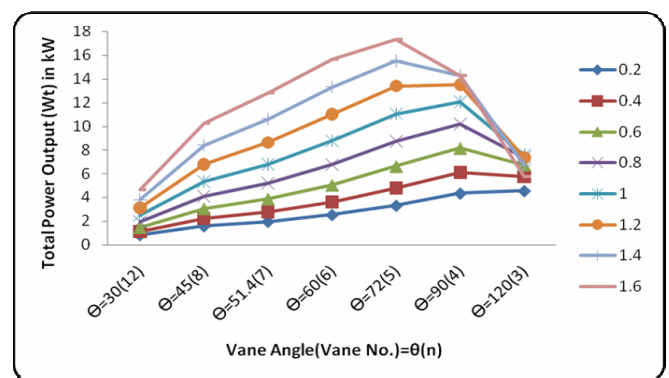

Fig. 8 Total turbine Power output vs Vane angle at different Injection to Vane angles ratio, Injection pressure 6 bar and Speed of Rotation 2500 rpm

Variation of total power output at different vane angles with respect to injection angle to vane angle ratios is shown at air injection pressure of 6 bar and speed of rotation 2500 rpm in Figures 8. Total work output is seen low at vane angle 30° and thereafter it gradually increases with increase in vane angles from 45° to 90°.for injection to vane angle ratios 0.2-1.2 and thereafter it decreases rapidly from 90°-120°. Hence optimum power output is seen for all injection to vane angle ratios from 0.2 -1.2, at vane angle 90° (4 vanes). Similar variations of expansion power are also obtained for injection to vane angle ratios 1.4 -1.6 but optimum power output appears at vane angle 72° (5 vanes). Also total power output is found small at lower speed of rotation of 500rpm and 1500 rpm (Figs. are not shown here).

It is thus, observed that in the vane turbine total shaft power is combined effect of the component of expansion and exit flow power but major contribution is of expansion power. The contribution of exit flow power is varying approximately from 19.4% to 0.6% at admission pressure 6 bar and speed of rotation 2500 rpm. It is also learnt that the vane turbine develops large shaft power output at vane angle 90° (6 vanes) when injection to vane angle ratio is kept 0.2-1.2 and at vane angle 72° (5 Vanes) when injection to vane angle ratio is kept 1.4 -1.6 for injection pressures 6 bar and speed of rotation 2500 rpm.

## VII. CONCLUSIONS

From various observations recorded by using the above mathematical model and considering listed input parameters in the Table 1, following conclusions are drawn about the power output of a small vaned type air turbine:

- The decision of number of vanes or vane angles into air turbine has significant effect over the shaft power output.
- Ratio of injection angle to vane angle is also important factor for obtaining optimum output of air turbine.
- Total shaft power output developed from air turbine is combination of the expansion power and exit flow power and it gets affected significantly when variations in injection angles are applied.
- The large shaft power output is achieved when vane angle is fixed between  $45^{\circ}$ - $90^{\circ}$  (8 to 4 vanes respectively) for the variation of injection to vane angle ratio from 0.6-1.6, admission air pressure of 6 bar and speed of rotation 2500 rpm.
- The optimum power output is achieved at vane angle  $90^{\circ}$  (4 vanes) for variation of injection to vane angle ratios from 0.2 to 1.2 and it is also seen at vane angle  $72^{\circ}$  (5 vanes) for injection to vane angle ratios from 1.4 to 1.6 ratios.

Thus in the vaned type novel air turbine the optimum shaft power output is developed when rotor contains 4-5 vanes for changes in injection to vane angle ratios from 0.2 to 1.6. These parameters will be helpful in designing a novel air turbine.

## NOMENCLATURE

$d$	diameter of rotor (2r) in meter
$D$	diameter of outer (2R) cylinder in meter
$L$	length of rotor having vanes in meter
$m$	meter
$n$	no. of vanes = $(360/\theta)$
$N$	no. of revolution per minute
$P$	pressure in bar
$p_1, v_1$	pressure and volume respectively at which air strike the Turbine,
$p_4, v_4$	pressure and volume respectively at which Maximum expansion of air takes place,
$P_5$	pressure at which turbine releases the air to atmosphere.
$r$	radius of rotor ( $d/2$ ) in meter
$R$	radius of outer casing ( $D/2$ ) in meter
$v$	volume in cu-m
$w$	theoretical work output in Nm
$W$	theoretical power output (Nm/s)
$X_{1i}$	variable extended lengths of vane at point 1
$X_{2i}$	variable extended lengths of vane at point 2
bar	(1 / 1.0132) atmospheric pressure

cu-m	cubic meter
kW	kilo-watt
Nm	newton meter
rpm	revolution per minute

## Subscripts

$1, 2, \dots, 5$	subscripts – indicates the positions of vanes
e, exp	expansion
f, flow	flow
t, total	total
min	minimum
max	maximum

## Geek symbols

$\alpha$	angle BOF
$\alpha_1$	angle LOF ( $=180-\phi$ )
$\alpha_2$	angle KOF ( $=180-\theta-\phi$ )
$\beta$	angle BAF
$\gamma$	1.4 for air
$\theta$	angle between 2-vanes (BOH)
$\phi$	angle at which compressed air enters into rotor through nozzle
$\xi_d$	eccentricity ( $R-r$ )

## REFERENCES

- [1] Hubbert M.K., 1956, Nuclear energy and the fossil fuels; Amer. Petrol. Inst. Drilling and Production Practice, *Proc. Spring Meeting*, San Antonio, Texas. 7-25.[#187].
- [2] Aleklett K. and Campbell C.J., 2003, The Peak and Decline of World Oil and Gas Production- *Minerals and Energy, Raw Materials Report*, Volume 18, Number 1, 2003, pp. 5-20(16).
- [3] Singh B.R. and Singh Onkar, 2007, Use of Non-Conventional Energy for Sustainability to Fossil Fuel, *National Conference on Recent Trend on Mechanical Engineering, RAME-2007*, held on 28-29th March'2007 at Baba Sahab Dr. Bhim Rao Ambedkar College of Agricultural Engineering and Technology, Etawah-Proceedings pp 130-136.
- [4] Singh B.R. and Singh Onkar, 2007, Uses of Wind Power as a Non-Conventional / Renewable Energy for Sustainability, *National Conference on State of Art Technology in Mechanical Engineering, STEM-2007*, held on October 29-31, 2007 at College of Technology, G.B. Pant University, Pant Nagar, UP-Proceedings pp 503-515.
- [5] Honton E. J., 2004, Hydrogen Fuel Cell Car, presented at *15th Annual US Conference and Hydrogen Expo*, April'2004, USA.
- [6] Rose Robert and William J. Vincent, 2004, Fuel Cell Vehicle World Survey 2003, *Breakthrough Technologies Institute*, February' 2004, Washington, D.C.
- [7] Singh B.R. and Singh Onkar, 2006, Necessity and Potential for Bio-Diesel Use in India, *International Conference on Bio-Fuel Vision-2015*, October'13th -15th, 2006 at Bikaner, India- Proceedings pp 71-89.
- [8] Singh B.R. and Singh Onkar, 2006, Study of Compressed Air as an alternative to fossil fuel for Automobile Engines, *International Conference on Challenges and Strategies for Sustainable Energy and Environment-* held on 10-11th June'2006 at UPTU, Lucknow, UP-Proceedings pp 179-191.
- [9] Singh B.R. and Singh Onkar, 2008, A Study on Sustainable Energy Sources and its Conversion Systems towards Development of an Efficient Zero Pollution Novel Turbine to be used as Prime-mover to the Light Vehicle, *2008 ASME International Mechanical Engineering Congress and Exposition*, held on October 31-November 6, 2008 at Boston, Massachusetts, USA- Paper No. IMECE -2008 -66803.
- [10] Negre Guy and Negre Cyril, 2004, Compressed Air - The Most Sustainable Energy Carrier for Community Vehicles, Speech in front of

assembly at Kultur gathered for *Fuel Cells World*, Tuesday 29th June '2004.

- [11] Saint Hilaire G., Saint Hilaire R. and Saint Hilaire, Y., 2005, Quasiturbine zero pollution car using gasoline. *Festival at Le Lundi, Montreal Gazette*, 26 September 2005.
- [12] Singh B.R. and Singh Onkar, 2008, Development of a vaned type novel Air Turbine, *International Journal of Mechanical Engineering Science* (The manuscript was received on 21<sup>st</sup> December 2007 and was accepted after revision for publication on 03<sup>rd</sup> June 2008), *International Journal of IMechE* Vol. 222 Part C, pp 1419-1426.
- [13] Knowlen C., Bruckner A. P., Mattick A.T. and Hertzberg A., 1998, High Efficiency Energy Conversion Systems for Liquid Nitrogen Automobiles, *Society of Automotive Engineers, Inc., AIAA* 98-1898.
- [14] Fuglsang P., Bak C. and Gunna M., 2004, Design and verification of the Ris0-B1 Airfoil-family for Wind Turbines, *Journal of Solar Energy Engg.*, ASME- Nov'2004, Vol.126 pp 1002-1008.
- [15] Gorla R. and Reddy, S., 2005, Probabilistic Heat Transfer and Structural Analysis of Turbine Blade, *IJTJE*, Vol. 22, pp 1- 11.
- [16] Selig Michel S. and Bryan D. McGranahan, 2004, Wind Tunnel Aerodynamics Tests of Six Airfoils for use on Small Wind Turbines, *Journal of Solar Energy Engg.*, ASME-Nov'2004, Vol.126, pp986-1000.
- [17] Schreck S. and Robinson M., 2004, Tip Speed Ratio Influences on Rationally Augmented Boundary Layer Topology and Aerodynamic Force Generation, *Journal of Solar Energy Engg.*, ASME-Nov' 2004- Vol.126 pp1025-1033.
- [18] Singh B.R. and Singh Onkar, 2008, A concept for Development of a Vaned Type Novel Air Turbine, *12<sup>th</sup> International Symposium on Transport Phenomena and Dynamics of Rotating Machinery* - held on February 17-22, 2008 at Pacific Center of Thermal-Fluids Engineering, Sheraton Mohana Surfriider Hotel Honolulu, Hawaii - Paper No. ISROMAC-12-20046.
- [19] Singh B.R. and Singh Onkar, 2008, Energy Storage System to meet Challenges of 21<sup>st</sup> Century- an Overview, *All India Seminar on Energy Management in Perceptive of Indian Scenario*-held on October 17-19, 2008 at Institution of Engineer (India), State Centre, Engineer's Bhawan, Lucknow-Proceedings Chapter15, pp 157-167.
- [20] Singh B.R. and Singh Onkar, 2008, A Study to Optimize the Output of Vaned Type Novel Air Turbine, *4<sup>th</sup> International Conference on Energy Research and Development*, held on 17-19 November, 2008 at State of Kuwait, Kuwait- Paper No. ICERD - 4 -1353.
- [21] Singh B.R. and Singh Onkar, 2008, Parametric Evaluation of Vane Angle on performance of Novel Air Turbine, *Journal of Science, Engineering and Management*, SITM , December, 2008, Vol. 2, pp 7-18.
- [22] Singh Onkar, 2009, Reciprocating and Rotary Compressor, *Applied Thermodynamics*, *New Age International (P) Ltd., Publishers, India*, ISBN: 978-81-224-2583-3, Feb2009, pp797-798.