

Predicting Individual Investors' Intention to Invest: An Experimental Analysis of Attitude as a Mediator

Azwadi Ali

Abstract—The survival of publicly listed companies largely depends on their stocks being liquidly traded. This goal can be achieved when new investors are attracted to invest on companies' stocks. Among different groups of investors, individual investors are generally less able to objectively evaluate companies' risks and returns, and tend to be emotionally biased in their investing decisions. Therefore their decisions may be formed as a result of perceived risks and returns, and influenced by companies' images. This study finds that perceived risk, perceived returns and trust directly affect individual investors' trading decisions while attitude towards brand partially mediates the relationships. This finding suggests that, in courting individual investors, companies still need to perform financially while building a good image can result in their stocks being accepted quicker than the stocks of good performing companies with hidden images.

Keywords—Behavioral Finance, Investment, Attitude towards Brand, Partial Least Squares

I. INTRODUCTION

INDIVIDUAL investors are increasingly being regarded as vital to companies in the management of stock values [1]. Relative to institutional and professional investors, these investors can easily and quickly participate in, or withdraw from, the market depending on their confidence in the prevailing market conditions. For example, total household ownership in the Australian stock market has shown a declining trend, from a high of 55% in 2004, to 46% in 2006, and a low of 41% in 2008 [2]. Such losses of investors in a short period of time can cost companies' stocks dearly. Similarly, failing to attract them when the economy recovers can restrict a company's stocks from reaching their highest possible value.

Research on behaviors of individual investors has shown that their trading decisions are often psychologically biased. Despite having evaluated the financial position of a company, many individual investors are still subject to certain emotional elements such as attitudes and brand familiarity [3]-[4]. In addition, many individual investors are not well equipped to handle financial matters and make quality investment decisions [5]-[6]. As a result, their Do-It-Yourself decisions tend to be more speculative, they trade more often and monitor their portfolio too frequently [7]-[8]-[9]. However,

A. Ali is with the Universiti Malaysia Terengganu, Terengganu, Malaysia (e-mail: azwadi@umt.edu.my).

the purpose of this study is not to address investors' exposure to potentially undesirable financial consequences resulting from these behaviors; rather it concerns itself with how companies can appreciate from having strong brand equity in their efforts to encourage individual investors' to invest in their stocks. Therefore, this study is interested in examining the relationships between individual investors' perceived financial performance of companies and their trading intentions, and the mediating effect of companies' images on the relationships.

II. THEORETICAL DISCUSSION AND HYPOTHESIS DEVELOPMENT

A. Equity Investment

The relatively high returns expected from equity have tended to attract many people in most economies to participate in stock markets in recent years. This is because stocks represent a good choice for a risky, high-return asset suited to long-term investing. However, a decision on whether or not to own stocks represents a combination of choices including whether having investments is reasonable at a particular point in one's lifecycle, especially for very young households [10]. As has been documented in related literature, investment in public equity can vary according to several factors including age, gender, health, wealth and home ownership status. Moreover, at the aggregate level, investment in equity moves very much in accordance with levels of market confidence in the prevailing economic conditions [11]. Therefore, it is important to understand that despite equity ownerships promising high returns, there are various factors associated with fluctuations over time and the moderate levels of stock ownership observed across the globe.

B. Behavioral Finance

Behavioral finance encompasses research that is not based on the traditional assumptions of expected utility maximization by rational investors in efficient markets [12]. Instead, it relies on two strong arguments: that the ways people think tend to differ from one another (cognitive psychology); and that there are limits to arbitrage (i.e. when markets are inefficient). Empirical support has been found for these two aspects making up behavioral finance in explaining investor behavior. Due to cognitive psychology which endeavors to explain investor behaviors, some patterns of cognitive bias have been identified in related research. These

include the biases of overconfidence, heuristics, mental accounting, disposition effect and conservatism which have been associated with gender, age, entrepreneurship, culture, excessive extrapolation, loyalty and familiarity.

Most people believe they are more skilful or knowledgeable than they really are [13]. For example, many people think highly of their ability to make wise choices in investment by timing the market and picking the next hot stocks that will yield the highest returns. When the market is rising, most stocks tend to do well. These stocks most likely include those that they have picked and again, most people will take that as confirmation of their acumen [14]. On the other hand, when their stocks drop in price, they will generally blame it on circumstances over which they had no control, such as the general condition of the market and the economy. Such self-perceived competence has been found to play a role in investors' willingness to act on their own judgment [15]-[16]. For instance, Graham et al. [16] have documented that perceived competence leads to overconfident investors who trade too often.

Investors following the rules of heuristics tend to pursue suboptimal investment decisions. In equity investment, investors face too many pieces of information, some being more useful than others. Therefore, when it is difficult to make investment decisions, they are likely to follow three major heuristics including 'availability', 'representativeness' and the '1/N rule'. For example, investors find it is easier to invest in stocks that are easily available to them (e.g. local and familiar stocks). Although knowing that the benefit from risk diversification can be better achieved by managing portfolios of local and international assets, many individual investors may find it costly and time-consuming to learn about unknown international stocks or less familiar local stocks. Moreover, many investors undervalue long-term averages, but tend to put too much weight on the recent experience [12]. This has led to many investors investing in more *glamour* stocks than *value* stocks.

Too often, individual investors' decisions may be fuelled by recommendations from peers and family. In seeking investment advice and information, 36% of direct investors surveyed by the ASX in 2008 reported that they sought advice from trusted family and friends [2]. Similarly, individuals may find it easier to learn about opening a mutual fund account by talking to their friends than through using other mechanisms [17]. Even without verbal recommendations or advice, people watch the behaviors of others and learn through interacting with them, hence behaving accordingly.

C. Intention to Invest

According to the Theory of Planned Behavior (TPB), people act in accordance with their intentions and perceptions of control over a particular behavior, while intentions in turn are influenced by attitudes towards the behavior, subjective norm and perceptions of behavioral controls [18]-[19]. In mapping the TPB to the context of the current study, individual investors' attitudes towards stock trading may be

strong as they are making decisions to achieve a desired level of financial stability, whereas family and peers' recommendations and behaviors in stock trading may form the 'subjective norm' variable. In addition, the 'perceived behavioral control' conceptualized as an antecedent to 'intention' within the TPB is defined as an individual's perception of the easiness of performing a particular behavior.

In the context of this study, investors may be interested in investing in a particular company only when they have time and skill to evaluate the company and have money to invest. Therefore, when forming an intention to invest, individual investors normally begin with evaluations of companies' financial positions based on some objective measures such as return on equity, dividend payout ratio and beta. Next, their emotional perceptions of such evaluations may come into effect as they are trying to justify their investing decisions in the companies' stocks.

As this study assumes that financial evaluation of companies' worth is a common activity of most individual investors, it is only interested to examine the effect of their subjective measures of companies' risk and returns on trading decisions. In addition, the role of trust, familiarity and the mediating role of attitude towards companies' images also form the research model in Fig. 1.

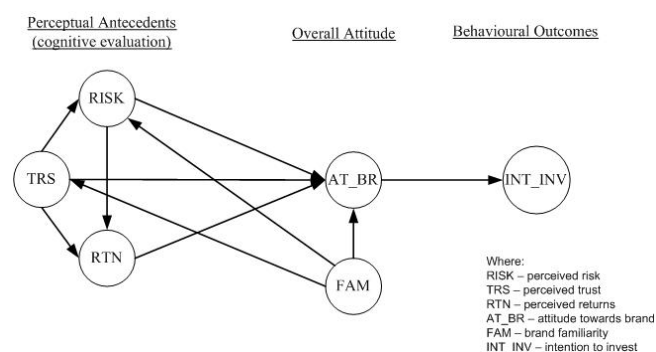

Fig. 1 Research model

As indicated in Fig. 1, this study conceptualizes the attitude towards brand (AT_BR) as having the full mediation effect on intention to trade, while perceived risk (RISK), perceived returns (RTN), trust (TRS) and brand familiarity (FAM) are the antecedents of AT_BR. Therefore, the main hypothesis of this study is given as H1:

H1. Attitude towards brand is positively related to intention to invest.

D. Perceptual Antecedents of Attitude towards Brand

Risks are normally measured by earnings volatility including standard deviations and betas, whereas returns can be measured by historical earnings such as dividends and capital appreciation. If, on average, investors can reasonably measure a company's risks and returns, and subsequently make their investment decisions, they are called rational investors. Accordingly, a rational, risk-averse investor requires an increase in the expected future returns from any

more risky investment in order to compensate for any potential volatility. Nevertheless, the present study adopts the subjective measures of risks and returns rather than their traditional objective measures such as betas and capital appreciation. In making investment decisions, these subjective measures of risks and returns are commonly used by novice investors who own relatively small investment portfolios as compared to professional investors [20]. Furthermore, the behavioral finance literature suggests that the relationship between perceived risks and perceived returns is inverse rather than positive [21].

The risks of a company can also be spread via word of mouth. Peers and family are also known to be the main information sources for investors [2]-[22]. The effects of word of mouth are stronger in the event that those who spread such information have had real experience investing in a particular company, both positive and negative. For example, an investor who has had a positive experience investing in a particular company due to consistent capital appreciation and reasonable dividend payments is likely to recommend, or at least talk positively, about that company to friends and family. When combined with positive professional reports by financial analysts or even good 'testimonials' from online social groups, investors will then form a positive attitude towards that company's image. Therefore hypotheses related to RISK is stated as:

H2a. Perceived risk is negatively related to attitude towards brand'.

H2b. Perceived risk is negatively related to perceived returns.

Trust can be defined as "the willingness of a party to be vulnerable to the actions of another party" [23, p. 712]. In this situation, stockholders as the owners of a company put their trust into the management team who are appointed to run the company. When the interest of the appointed management differs from that of stockholders, agency problems tend to occur, leading stockholders to assume some agency cost such as remunerating highly performing managers with special incentives and appointing board of directors to oversee the conduct of the management. However, even the existence of boards of directors is subject to conflicting goals, because appointed directors may mistakenly assume stockholders' interests. When this occurs, chances are that investors do not trust the management and board of directors, and perceive investing in that company to be highly risky.

A company's reputation is also strengthened when investors have a high level of trust in it. Siegrist and Cvetkovich [24] assert that cognitive trust is normally given greater weight than affective trust, when a particular hazard (e.g. financial loss) being evaluated is familiar to the trustor (e.g. investors). Affective trust is demonstrated when the trusted party including the management and directors are believed to have demonstrated fairness, compassion and integrity [25].

A company with good historical earnings is definitely a strong choice when compared to one with volatile historical returns. When investors have determined that a company has

had satisfactory returns in the past, they will likely perceive that this trend will hold in the future. In other words, one can view this situation as investors having achieved cognitive or evaluative trust. Cognitive trust is primarily related to perceived competence and reliability of the provider, where perceived competence is easily demonstrated by past performance [26]. Therefore, hypotheses tested on the trust variable are as follows:

H3a. Perceived trust is positively related to attitude towards brand.

H3b. Perceived trust is negatively related to perceived risk.

H3c. Perceived trust is positively related to perceived returns.

Investors tend to perceive historical returns to hold in the foreseeable future. Hence, they evaluate financial performance of the past several years and make some anticipation of the likelihood of the company's returns in the future. Since individual investors are generally lack of ability to properly evaluate such returns, their perceptions of company's returns may play a greater role, or at least their evaluations lead them to form such perceptions. Therefore, the hypothesis of perceived returns is stated as:

H4. Perceived returns is positively related to attitude towards brand.

E. Brand Familiarity

Although a brand has been normally associated with a name and/or symbol-like logo, the trademark and package design that differentiate it from its competitor [27], its name is believed to be the primary brand factor [28]-[29]. A company name is important for investors' evaluations of its brand benefits and hence conceptualized as an antecedent of consumers' attitudes towards a brand. In the context of investment, investors have been found to incline towards investing in the companies that they are familiar with [3]-[30]-[31]. For instance, Aspara and Tikkanen [3] found that individual investors who engage in investment behaviors and trading of stocks of certain companies also engage in other economic behavior, notably in the area of product consumption.

Familiarity towards a company can also influence consumers' perceived risk of the company because they use company-specific facts to arrive at their expectation as to risk and returns [32]-[33]. Therefore, knowing the name of an investment becomes crucial, as it indicates the type, market and other specific characteristics of that particular stock. For example, participants in a study underestimated the riskiness of domestic stocks relative to those of foreign stocks [34].

When an investor's familiarity of a company is high, their inclination to trust the company can also be expected. For instance, one may put more trust into a company because of knowing that a director of the company is a well-known national figure. Similarly, should a problem occur after owning a company stock, an investor would find access to a familiar organization in order to lodge a query or complaint relatively easier and more convenient than with an unfamiliar

organization. All of the above arguments helped the study to test the following hypotheses related to FAM:

H5a. Brand familiarity is positively related to attitude towards brand.

H5b. Brand familiarity is negatively related to perceived risk.

H5c. Brand familiarity is positively related to perceived trust.

III. RESEARCH METHOD AND DESIGN

A. Data and Unit of Analysis

The intended unit of analysis in the present study is individual investors. However, since one of the main aims of the study was to establish internal validity of a proposed model, a proxy for individual investors was chosen. Important aspects such as knowledge, skills and involvement were carefully considered when selecting this proxy in order to also meet external validity. As a result, 341 undergraduate students enrolled in the Investment and Portfolio Management subject at a major university in Victoria, Australia have been identified and selected as the study's sample frame. From this sample frame, 136 usable responses were gathered during six weeks of administering the survey between April and May 2009.

An online survey method was employed to collect respondents' answers following a free simulation experiment [35]. Online surveys are regarded as advantageous since they can overcome place and time constraints [36], whereas free simulation experiments avoid fictitious study cases. The survey was conducted as such that the students answered it in their own preferred time, not in a laboratory setting. The students were highly involved when completing the survey because they were also completing a stock valuation assignment to mimic actual evaluation tasks of real investors. In completing the assignment, they were asked to obtain information from related avenues including the Australian Securities Exchange (ASX) website, online financial portal and the websites of three selected companies¹. This selection has followed a narrowing technique to avoid having too many companies but at the same time ensuring that these companies have certain differing characteristics such as size, industry types and brand familiarity.

B. Measurement and Questionnaire

Attempts to use existing measurement related to each construct were taken, however measures of some constructs especially those of the brand antecedents were specifically developed for the study. A cautious approach was taken in the measurement of these brand evaluative responses, so that specific constructs explaining such responses that are relevant to the context of stock investments, rather than product purchase decisions, can be identified. Although specifically developed, the measures of RISK, RTN and TRS have been

mapped to the measures used in behavioral finance literature [37]-[38]-[39]-[40]. Similarly, the measures of FAM construct were developed based on ideas proposed by Aspara and Tikkanen [3]. 7-point Likert scale items were used to measure these exogenous constructs.

On the other hand, measures of the endogenous variables (INT_INV and AT_BR) were based on existing measures used in earlier studies in related fields [41]-[42]. To be consistent with the measures of exogenous variables, both 7-point Likert scale items and 7-bipolar points semantic differential items were used to represent the endogenous variables. Note however that the questions directed at the construct of INT_INV were adapted from the questions commonly used in product-purchase situation to suit the investing context of the present study. All of the measures for each variable have been adequately piloted and found to be reliable and unambiguous. The overall questionnaire can be found in Table I.

Data from the 136 responses were first refined. In doing so, an exploratory factor analysis was run on all original measures before the model with valid measures was finalized for hypothesis testing. This analysis has resulted in three original indicators being dropped. These were RISK2, RTN4 and TRS1. The final model with respective valid indicators is given in Fig. 2.

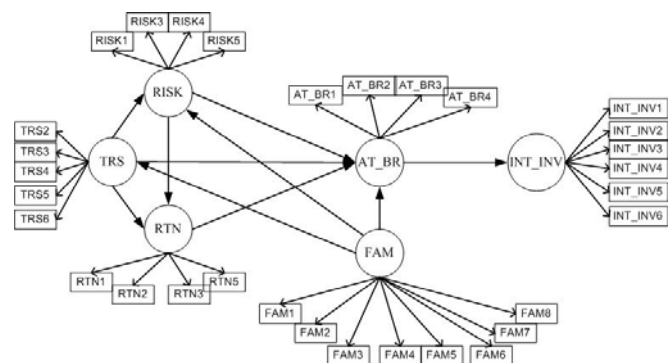

Fig. 2 Research model with valid indicators

C. Analysis of Data

Data analysis was based on partial least squares (PLS) path modeling to test hypotheses included in the research model. This method was chosen due to normality assumptions of the data distribution have not been met and small sample size of 136 responses. The specific PLS tool used in the present study is SmartPLS, a PLS application that can be used for free [43].

¹ These companies include Woolworths, Lion Nathan and Super Cheap Auto.

TABLE I
MEASURES OF LATENT CONSTRUCTS

Constructs ^a
Perceived Risk (RISK) – reflective, 1 st order
RISK1 – It is a risky decision to invest in WL.
RISK2 – I am sure that WL is a right investment choice. ^b
RISK3 – WL has uncertain future.
RISK4 – I better invest my fund somewhere else other than in WL.
RISK5 – I think investing in WL is highly risky.
Perceived Returns (RTN) – reflective, 1 st order
RTN1 – WL is financially sound.
RTN2 – Investing in WL seems to be able to generate me high returns.
RTN3 – I believe WL will perform satisfactorily in the future.
RTN4 – WL has sufficient resource to grow in the future.
RTN5 – I think investing WL is highly rewarding.
Trust (TRS) – reflective, 1 st order
TRS1 – WL is unreliable. ^b
TRS2 – I can rely on the promises made by WL.
TRS3 – WL management is competent to run its business.
TRS4 – I believe that WL will not hide important information from its investors' knowledge.
TRS5 – WL has reliable members of board of directors.
TRS6 – In my opinion, WL is trustworthy.
Brand Familiarity (FAM) – reflective, 1 st order
FAM1 – I am very familiar with the company's name.
FAM2 – I know a lot about the company's main nature of business.
FAM3 – The company is highly recognized.
FAM4 – I always hear the company's name mentioned in the media
FAM5 – I often see the company's advertisements in the media.
FAM6 – I know that the company does business in Australia.
FAM7 – I know that the company is listed on the Australian Securities Exchange.
FAM8 – When I hear the company's name, I immediately recall a particular product.
Attitude towards Brand^f
AT_BR1 – unfavorable ↔ favorable
AT_BR2 – bad ↔ good
AT_BR3 – negative ↔ positive
AT_BR4 – weak ↔ strong
Intention to Invest (INT_INV)^d
If I actually had the money to invest;
INT_INV1 – the likelihood of me investing in WL is ...
INT_INV2 – the probability that I would buy WL's stock is ...
INT_INV3 – my willingness to buy WL's stock is ...
If I actually thought of investing;
INT_INV4 – WL is definitely one of my choices.
INT_INV5 – I would refer WL's stocks to others.
INT_INV6 – I would talk positively about WL to others.

^a All constructs are in reflective and first order mode.

^b Reversed items.

^c 7-point bipolar semantic differential items.

^d 1 denoting 'very low' and 7 denoting 'very high'.

IV. RESULTS

A. Measurement Model

In utilizing a PLS path modeling technique, a similar two-step procedure normally conducted in structural equation modeling (SEM) was followed [44]. Through this technique, results of both confirmatory factor analysis of the model and path effect were obtained. In completing this procedure, a model validation analysis was also performed.

Results of the measurement model using a PLS algorithm (300 maximum iteration, standardized values and centroid weighting scheme) suggest that all constructs that were made up of reflective indicators are reliable with loadings all above the desired level of 0.70 (see Table II).

TABLE II
LOADINGS OF INDICATORS

	Loadings		Loadings
AT_BR			
AT_BR1	0.897087	TRS5	0.858827
AT_BR2	0.932228	TRS6	0.859617
AT_BR3	0.901070	FAM	
AT_BR4	0.883513	FAM1	0.885717
RISK		FAM2	0.898470
RISK1	0.917424	FAM3	0.892427
RISK3	0.816382	FAM4	0.864319
RISK4	0.745651	FAM5	0.883561
RISK5	0.901206	FAM6	0.827675
RTN		FAM7	0.894826
RTN1	0.896061	FAM8	0.884072
RTN2	0.831771	INT_INV	
RTN3	0.881123	INT_INV1	0.945293
RTN5	0.879804	INT_INV2	0.953384
TRS		INT_INV3	0.941371
TRS2	0.758098	INT_INV4	0.952110
TRS3	0.843946	INT_INV5	0.880552
TRS4	0.824444	INT_INV6	0.909222

B. Model Validity

In SEM, a research model is said to be valid when both convergent and discriminant validity have been achieved. Table III and Table IV provide the results of these validity tests. The research model demonstrates a strong convergent validity as the latent constructs with reflective items have high composite reliability (CR) and communality.

TABLE III
CONVERGENT VALIDITY

	No. of items	CR	AVE	Communality
RISK	4	0.910481	0.719078	0.719078
RTN	4	0.927260	0.761300	0.761300
TRS	5	0.916914	0.688638	0.688638
FAM	8	0.964553	0.772905	0.772905
AT_BR	4	0.946813	0.816584	0.816584
INT_INV	6	0.974884	0.866211	0.866211

TABLE IV
DISCRIMINANT VALIDITY

	RISK	RTN	TRS	FAM	AT_BR	INT_INV
RISK	.848*					
RTN	-.552	.873				
TRS	-.449	.756	.830			
FAM	-.310	.241	.348	.879		
AT_BR	-.292	.385	.414	.882	.904	
INT_INV	-.561	.866	.777	.326	.448	.931

* Diagonal elements are square roots of AVE.

As can be seen in Table IV, the square roots of all average variance extracted (AVE) were greater than inter-construct correlations except for the constructs of FAM and AT_BR. As the difference between the square root of AVE for FAM is less than the inter-correlation between the two constructs by merely 0.003, this study contends that the research model has achieved desirable discriminant validity.

C. Structural Model

Using a bootstrapping technique (500 re-samples), a test on the structural model was conducted to assess the effect of each causal path, thus testing the stipulated hypotheses. As can be seen in Fig. 3, except for TRS→AT_BR path, all other causal paths are significant at 5% level of significance. The relationship between RISK and AT_BR turned out to be positive, albeit just significant at 5% confidence level. In summary, only H2a and H3a were not supported. Therefore, majority of the hypotheses were supported suggesting that attitude plays a mediating role for investors to decide in investing in stocks of a particular company after forming their perceptions of its financial performance.

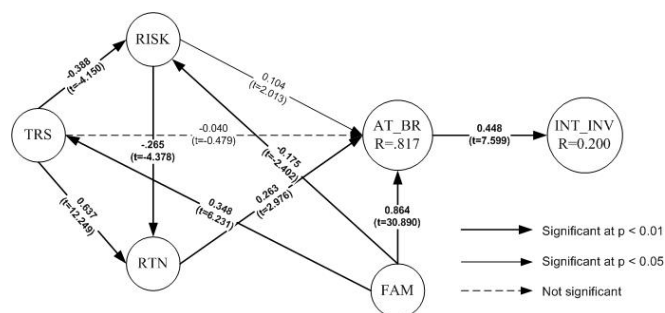

Fig. 3 Results of structural model

D. Model Fit

The research model explains 20% variance in the INT_INV variable. Although it seems moderate, the path effect of AT_BR↔INT_INV is near 0.50 and significant. Additional model fit was assessed through obtaining the cv-communality (H^2) and cv-redundancy (Q^2) by running a blindfolding procedure. The results in Table V show the research model having better a measurement model ($H^2 = 0.770820$) than the structural model ($Q^2 = 0.385374$). As indicated by Chin [48], a Q^2 value of greater than zero has predictive relevance, so Q^2 of 0.385374 is considered far greater than this heuristic. Overall, the research model exhibits acceptable fit and high predictive relevance.

TABLE V
 MODEL FIT STATISTICS

Construct	Structural Model		Model Quality (H^2)	Model Quality (Q^2)
	variance	comm. redundancy		
INT_INV	0.20037 ^a	(0.86621) ^b	0.17288 ^c	0.86607 ^d (0.17220) ^e
AT_BR	0.81688	(0.81658)	0.64486	0.81651 (0.65943)
RISK	0.22887	(0.71908)	0.05675	0.71942 (0.16338)
RTN	0.62856	(0.76130)	0.16430	0.76130 (0.46521)
TRS	0.12137	(0.68864)	0.08148	0.68860 (0.08041)
FAM	-	(0.77291)	-	0.77301 (0.77162)
Average	0.39921	0.77457^f	0.22405	0.77082 (0.38537)
GoF^g	0.55607			

a = variance explained, b = communality, c = redundancy, d = cv-communality, e = cv-redundancy, f = computed as a weighted average of the different communalities with the weights being the number of manifest variables per construct [46, p.306, 47, p.180], g = GoF equals $\sqrt{[(\text{average communality}) \times (\text{average } R^2)]}$.

E. Revised Model

Although the results of PLS procedure show that the research model has satisfactorily explained the research questions of the study, a full mediation analysis was conducted in order to assess the full mediation effect of AT_BR. In addition, the variance explained in the intention to invest construct seems moderate at 20%, and the positive relationship between RISK and AT_BR appears awkward. In running a mediation analysis, four rules of mediation, as suggested by Baron and Kenny [49] were followed. The results of this analysis are presented in Table VI.

TABLE VI
 PLS RESULTS OF ALTERNATIVE MODELS

	Full Mediation R^2 or β or γ	Partial Mediation R^2 or β or γ	No Mediation R^2 or β or γ
INT_INV (R^2)	0.200	0.804	0.798
AT_BR (R^2)	0.817	0.817	0.821
AT_BR→INT_INV	0.448*	0.089*	N/A
RISK→AT_BR	0.104*	0.102	0.100
TRS→AT_BR	-0.040	-0.041	-0.043
RTN→AT_BR	0.263*	0.264*	0.260*
FAM→AT_BR [^]	0.864*	0.866*	0.870*
RISK→RTN	-0.265*	-0.264*	-0.263*
TRS→RISK	-0.388*	-0.387*	-0.387*
TRS→RTN	0.637*	0.636*	0.636*
FAM→RISK	-0.175*	-0.175*	-0.175*
FAM→TRS	0.348*	0.348*	0.348*
RISK→INT_INV	N/A	-0.112	-0.111
TRS→INT_INV	N/A	0.258*	0.276*
RTN→INT_INV	N/A	0.575*	0.599*

*Significant at 5% level of confidence.
[^]The relationship between FAM→INT_INV was ignored as FAM is considered an attitudinal construct related to AT_BR.

As can be seen in Table VI, the variance explained for INT_INV construct by both partial and no-mediation models improved significantly. Since the path between AT_BR and INT_INV remained significant, albeit lower than in the original model, while the direct paths from brand evaluative constructs became significant, this suggests a partial mediation effect [49]. Note that although the path coefficient for AT_BR→INT_INV in the partial mediation model was only 0.089, it is significant at 5% level of confidence with a t-statistic of 2.325. Note also that the inter-relationship between exogenous variables did not change much due to PLS algorithm merely being repeated in each different model. Therefore this mediation analysis supports a partial mediation model for the attitudinal construct. At f^2 of 0.755, the effect size between the partial mediation and full mediation model is considered significantly high [48]-[50] with a Pseudo F value² of 98.905.

² f^2 is calculated as $(R^2_{\text{Revised}} - R^2_{\text{Original}}) / (1 - R^2_{\text{Original}})$, see [51]. Pseudo F = $f^2 (n - k - 1)$ is significant at 0.01 when F-value > 6.83 [52].

V. DISCUSSION OF RESULTS

A. Implications of the Findings

Overall, the research model has satisfactorily explained the ultimate dependent variable, INT_INV with 20% variance being explained. For hypothesized perceptual antecedents of attitude towards brand, the perceived returns construct has a significant path effect on the attitudinal variable, whereas the relationship between perceived risk and attitude towards brand was found to be positive. In addition, the brand familiarity construct is positively significant in affecting the attitude towards brand. Trust on the other hand failed to predict investors' attitude towards a brand. As a result of the seemingly moderate amount of variance in the investors' behavioral variable being explained by the original research model, this study has expanded its analysis to include a mediation analysis. This analysis has resulted in a revised model that is able to explain a considerably larger variance in the INT_INV construct, with significant effect size.

The findings of this study affirm that investors are users with specific informational needs including the need to adequately evaluate companies' risks and returns, and not entirely influenced by emotional factors when deciding to invest in a particular stock. Since the revised model suggests a partial mediation effect by the attitude towards brand construct, the findings still support the claim in extant literature that investor behaviors may be emotionally biased [3]. In conclusion, the present study has shown that in courting individual investors, companies may engage in marketing strategies that may enhance their image as viewed by investors, but at the same time need to remember that these investors still do their homework on evaluating the value of companies with regard to their financial performances.

The findings of this study have important implications to both theoretical and practical considerations. First, it was found that a research model based on the concept of attitude as a mediator can be applied in the context of investors evaluating a company before deciding to invest in stocks of a company. Being human, investors are subject to emotion and this emotional effect can be stronger when companies are seen appealing to investors via relevant marketing strategies. Therefore, investors' attitudes towards companies' brands can be expected to play an important role alongside cognitive evaluation of the companies in predicting their final behaviors of investing in the companies' stocks.

Second, there are specific perceptual antecedents to attitude towards brand that shape investors' overall affective evaluation of a particular brand. Among these antecedents, perceived returns is significantly related to attitude towards brand, and as expected, brand familiarity strongly predicts the attitudinal variable. Therefore, it is important to identify reliable antecedents of attitude towards brand in the formation of a research model that utilizes attitude as a mediating variable of investors' intentions.

Third, from a pragmatic perspective, companies should

continually engage in marketing strategies that may attract investors to invest in their stocks more quickly than by only relying on good periodical financial results.

B. Limitations of the Study

The research setting for the study was an educational institution and respondents were limited to undergraduates enrolled in the Investment and Portfolio Management unit at a university in Victoria, Australia. As such, the study's findings are limited due to the extent to which similar behaviors can be generalized to real investors could not be ascertained.

Since the research model used in this study relied upon perceptual measures through the use of a self-reported survey, the study findings may, to some degree have been tainted with response bias. However, from two relevant tests, it was found that common method bias was not a main concern.

Moreover, the research model used in this study relied on a number of pre-identified antecedent variables of the attitudinal construct. As such, these antecedents explain only a portion of the variances in the attitudinal construct and in the outcome variable. There may be other factors which, although not part of this study, may have significant influence on respective attitudes and investors' behaviors. Some examples include investors' risk preference, present economic condition and the different levels of their financial literacy. Therefore, future research may include these suggested variables in order to increase the robustness of the findings.

Finally, the study's findings are based on a modest sample size of 136 responses. Although PLS path modeling adequately handles small sample sizes and generates valid results, it is not as reliable as covariance-based structural equation modeling in testing relationships of multiple latent variables. Future research may verify the findings of this study by employing a larger sample that will permit the use of covariance-based SEM.

REFERENCES

- [1] P. Vogelheim, D. D. Schoebachler, G. L. Gordon, and C. C. Gordon, "The importance of courting the individual investor," *Business Horizons*, vol. 44, no. 1, pp. 69-76, 2001.
- [2] Australian Securities Exchange, *2008 Australian share ownership study*. Sydney: Australian Securities Exchange, 2009.
- [3] J. Aspara, and H. Tikkanen, "Interactions of individuals' company-related attitudes and their buying of the companies' stocks and products," *Journal of Behavioral Finance*, Vol. 9, no. 2, pp. 85-94, 2008.
- [4] M. Massa, and A. Simonov, "Hedging, familiarity and portfolio choice," *The Review of Financial Studies*, vol. 19, no. 2, pp. 633-685, 2006.
- [5] C. A. Looney, J. S. Valacich, P. A. Todd, and M. G. Morris, "Paradoxes of online investing: testing the influence of technology on user expectancies," *Decision Sciences*, vol. 37, no. 2, pp. 205-246, 2006.
- [6] E. Rubaltelli, S. Rubichi, L. Savadori, M. Tedeschi, and M. Ferretti, "Numerical information format and investment decisions: implications for the disposition effect and the status quo bias," *Journal of Behavioral Finance*, vol. 6, no. 1, pp. 19-26, 2005.
- [7] B. M. Barber, and T. Odean, "Online investors: do the slow die first?" *The Review of Financial Studies*, vol. 15, no. 2, pp. 455-487, 2002.
- [8] J. J. Choi, D. Laibson, and A. Metrick, "How does the Internet affect trading? evidence from investor behavior in 401(k) plans," *Journal of Financial Economics*, vol. 64, no. 3, pp. 397-421, 2002.
- [9] P. Konana, and S. Balasubramanian, "The social-economic-psychological (SEP) model in technology and usage: an application to

- online investing," *Decision Support Systems*, vol. 39, no. 3, pp. 505-524, 2005.
- [10] J. F. Cocco, F. J. Gomes, and P. J. Maenhout, "Consumption and portfolio choice over the life cycle," *The Review of Financial Studies*, vol. 18, no. 2, pp. 491-533, 2005.
- [11] W. J. Jansen, and N. J. Nahuis, "The stock market and consumer confidence: European evidence," *Economics Letters*, vol. 79, no. 1, pp. 89-98, 2003.
- [12] J. R. Ritter, "Behavioral finance," *Pacific-Basin Finance Journal*, vol. 11, no. 4, pp. 429-437, 2003.
- [13] B. M. Barber, and T. Odean, "Boys will be boys: gender, overconfidence, and common stock investment," *The Quarterly Journal of Economics*, vol. 116, no. 1, pp. 261-292, 2001.
- [14] R. Deaves, C. Dine, and W. Horton, *How are investment decisions made?* Toronto, ON: The Task Force to Modernize Securities Regulation in Canada, 2006.
- [15] C. R. Fox, and A. Tversky, "Ambiguity aversion and comparative ignorance," *The Quarterly Journal of Economics*, vol. 110, no. 3, pp. 585-603, 1995.
- [16] J. R. Graham, C. R. Harvey, and H. Huang, "Investor competence, trading frequency, and home bias," *Management Science*, vol. 55, no. 7, pp. 1094-1106, 2009.
- [17] J. R. Brown, Z. Ivkovic, P. A. Smith, and S. Weisbenner, "Neighbors matter: causal community effects and stock market participation," *Journal of Finance*, vol. 63, no. 3, pp. 1509-1531, 2008.
- [18] I. Ajzen, "From intentions to actions: a theory of planned behavior," in *Action Control: From Cognition to Behavior*, J. Kuhl, and J. Beckmann, Eds. New York: Springer, 1985, pp. 11-39.
- [19] I. Ajzen, "The theory of planned behavior," *Organizational Behavior and Human Decision Processes*, vol. 50, no. 2, pp. 179-211, 1991.
- [20] V. Ricciardi, "A risk perception primer: a narrative research review of the risk perception literature in behavioral accounting and behavioral finance," *SSRN Working Paper*, 2004.
- [21] V. Ricciardi, "A literature review of risk perception studies in behavioral finance: the emerging issues," *Proc. 25th Annual Meeting of the Society for the Advancement of Behavioral Economics Conference*, New York, 2007.
- [22] H. Loranger, and J. Nielsen, *Designing Websites to Maximise Investor Relations: Usability Guidelines for Investor Relations on Corporate Websites*. Fremont, CA: Nielsen Norman Group, 2003, pp. 1-124.
- [23] R. C. Mayer, J. H. Davis, and D. F. Schoorman, "An integrative model of organizational trust," *Academy of Management Review*, vol. 20, no. 3, pp. 709-734, 1995.
- [24] M. Siegrist, and G. Cvetkovich, "Perception of hazards: the role of social trust and knowledge," *Risk Analysis*, vol. 20, no. 5, pp. 713-719, 2000.
- [25] M. C. Clark, and R. L. Payne, "Character-based determinants of trust in leaders," *Risk Analysis*, vol. 26, no. 5, pp. 1161-1173, 2006.
- [26] R. A. Olsen, "Trust as risk and the foundation of investment value," *The Journal of Socio-Economics*, vol. 37, no. 6, pp. 2189-2200, 2008.
- [27] D. Aaker, *Managing Brand Equity*. New York: The Free Press, 1991.
- [28] L. L. Berry, "Cultivating service brand equity," *Journal of the Academy of Marketing Science*, vol. 28, no. 1, pp. 128-137, 2000.
- [29] D. F. Davis, S. L. Golicic, and A. J. Marquardt, "Branding a B2B service: does a brand differentiate a logistics service provider?" *Industrial Marketing Management*, vol. 37, no. 2, pp. 218-227, 2008.
- [30] L. Frieder, and A. Subrahmanyam, "Brand perceptions and the market for common stock," *Journal of financial and Quantitative Analysis*, vol. 40, no. 1, pp. 57-85, 2005.
- [31] G. Huberman, "Familiarity breeds investment," *The Review of Financial Studies*, vol. 14, no. 3, pp. 659-680, 2001.
- [32] W-Y. Huang, H. Schrank, and A. J. Dubinsky, "Effect of brand name on consumers' risk perceptions of online shopping," *Journal of Consumer Behavior*, vol. 4, no. 1, pp. 40-50, 2004.
- [33] E. U. Weber, N. Siebenmorgen, and M. Weber, "Communicating asset risk: how name recognition and the format of historic volatility information affect risk perception and investment decisions," *Risk Analysis*, vol. 25, no. 3, pp. 597-609, 2005.
- [34] M. Kilka, and M. Weber, "Home bias in international stock return expectations," *Journal of Behavioral Finance*, vol. 1, no. 3&4, pp. 176-192, 2000.
- [35] A. M. Jenkins, "Research methodologies and MIS research," in *Research Methods in Information Systems*, E. Mumford, R. A. Hirschheim, G. Fitzgerald and A. T. W. Harper, Eds. Amsterdam, Holland: North-Holland Publishing Co, 1985, pp. 103-117.
- [36] Y. D. Wang, and H. H. Emurian, "Trust in e-commerce: consideration of interface design factors," *Journal of Electronic Commerce in Organizations*, vol. 3, no. 4, pp. 42-60, 2005.
- [37] K. Bryne, "How do consumers evaluate risk in financial products?" *Journal of Financial Services Marketing*, vol. 10, no. 1, pp. 21-36, 2005.
- [38] E. Delgado-Ballester, and J. L. Munuera-Aleman, "Brand trust in the context of consumer loyalty," *European Journal of Marketing*, vol. 35, no. 11/12, pp. 1238-1258, 2008.
- [39] Y. Ganzach, S. Ellis, A. Pazy, and T. Ricci-Siag, "On the perception and operationalization of risk perception," *Judgment and Decision Making*, vol. 3, no. 4, pp. 317-324, 2008.
- [40] J. Nilsson, "Investment with a conscience: examining the impact of pro-social attitudes and perceived financial performance on socially responsible investment behavior," *Journal of Business Ethics*, vol. 83, no. 2, pp. 307-325, 2008.
- [41] E. J. Karson, and R. J. Fisher, "Predicting intentions to return to web site: extending the dual mediation hypothesis," *Journal of Interactive Marketing*, vol. 19, no. 3, pp. 2-14, 2005.
- [42] S. B. MacKenzie, R. J. Lutz, and G. E. Belch, "The role of attitude toward the ad as a mediator of advertising effectiveness: a test of competing explanations," *Journal of Marketing Research*, vol. 23, no. 2, pp. 130-143, 1986.
- [43] C. M. Ringle, S. Wende, and S. Will, *SmartPLS 2.0 Beta*. Hamburg: University of Hamburg, 2005.
- [44] J. S. Anderson, and D. W. Gerbing, "Structural equation modeling in practice: a review and recommended two-step approach," *Psychological Bulletin*, vol. 103, no. 3, pp. 411-423, 1988.
- [45] C. M. Ringle, S. Wende, and S. Will, "The finite mixture partial least squares approach: methodology and application," in *Handbook of Partial Least Squares: Concepts, Methods and Applications in Marketing and Related Fields*, V. E. Vinzi, W. W. Chin, J. Henseler and H. Wang, Eds. New York: Springer-Verlag, 2009.
- [46] P. Guenzi, L. Georges, and C. Pardo, "The impact of strategic account managers' behaviors on relational outcomes: an empirical study," *Industrial Marketing Management*, vol. 38, no. 3, pp. 300-311, 2009.
- [47] M. Tenenhaus, V. E. Vinzi, Y-M Chatelin, and C. Lauro, "PLS path modeling," *Computational Statistics & Data Analysis*, vol. 48, no. 1, pp. 159-205, 2005.
- [48] W. W. Chin, "The partial least squares approach to structural equation modeling," in *Modern Methods for Business Research*, G. A. Marcoulides, Ed. Mahwah, NJ: Lawrence Erlbaum Associates, 1998, pp. 295-336.
- [49] R. M. Baron, and D. A. Kenny, "The moderator-mediator variable distinction in social psychological research: conceptual, strategic and statistical considerations," *Journal of Personality and Social Psychology*, vol. 51, no. 6, pp. 1173-1182, 1986.
- [50] U. Konradt, T. Christophersen, and U. Schaeffer-Kuelz, "Predicting user satisfaction, strain and system usage of employee self-services," *International Journal of Human-Computer Studies*, vol. 64, no. 11, pp. 1141-1153, 2006.
- [51] D. Gefen, D. W. Straub, and M-C. Boudreau, "Structural equation modelling and regression: guideline for research practice," *Communications of AIS*, vol. 4, no. 7, pp. 1-77, 2000.
- [52] K. Mathieson, E. Peacock, and W. W. Chin, "Extending the technology acceptance model: the influence of perceived user resources," *The DATA BASE for Advances in Information Systems*, vol. 32, no. 3, pp. 86-112, 2001.

Azwadi Ali is a lecturer at the Universiti Malaysia Terengganu, Malaysia. He obtained his doctoral degree at the Victoria University, Australia. His research interests include behavioral finance, financial literacy and financial planning.