

Numerical Analysis of Concrete Crash Barriers

J. Kala, P. Hradil, and V. Salajka

Abstract—Reinforced concrete crash barriers used in road traffic must meet a number of criteria. Crash barriers are laid lengthwise, one behind another, and joined using specially designed steel locks. While developing BSV reinforced concrete crash barriers (type ŽPSV), experiments and calculations aimed to optimize the shape of a newly designed lock and the reinforcement quantity and distribution in a crash barrier were carried out. The tension carrying capacity of two parallelly joined locks was solved experimentally. Based on the performed experiments, adjustments of nonlinear properties of steel were performed in the calculations. The obtained results served as a basis to optimize the lock design using a computational model that takes into account the plastic behaviour of steel and the influence of the surrounding concrete [6]. The response to the vehicle impact has been analyzed using a specially elaborated complex computational model, comprising both the nonlinear model of the damping wall or crash barrier and the detailed model of the vehicle [7].

Keywords—Crash Barrier, impact, static analysis, concrete nonlinear model.

I. INTRODUCTION

IN the frame of activities carried out in order to enhance the safety of the road traffic, properly designed protective restraint systems are installed on roads. The restraints should reduce the consequences of a considerable number of road accidents. The restraints are installed either along road shoulders or along middle lines of road separator strips. The main purpose of the restraint is to keep the motion of the out-of-control vehicle within the roadway area, providing simultaneously a reasonable safety for passengers in the vehicle as well that for other involved road users. For the design of restraint systems installed on roads in Czech Republic, the respective authorities adopt harmonized European standards and national technical regulations. Consequently, a restraint system assigned for a specified type of road and design speeds of admissible vehicles should be designed so as to comply with the set of requirements defining a certain restraint function class.

It was performed experimental solution the tension carrying capacity of the steel lock of concrete crash barrier. Based on the performed experiments it was prepared nonlinear

Assoc. prof. J. Kala is with Brno University of Technology, Faculty of Civil Engineering, Department of Structural Mechanics, Veveří 95, 602 00 Brno, Czech Republic, (phone: +420-541-147-382; fax: +420-541-147-366; e-mail: kala.j@fce.vutbr.cz).

P. Hradil is with Brno University of Technology, Faculty of Civil Engineering, Department of Structural Mechanics, Veveří 95, 602 00 Brno, Czech Republic, (phone: +420-541-147-366; fax: +420-541-147-366; e-mail: hradil.p@fce.vutbr.cz).

Assoc. prof. V. Salajka is with Brno University of Technology, Faculty of Civil Engineering, Department of Structural Mechanics, Veveří 95, 602 00 Brno, Czech Republic, (phone: +420-541-147-365; fax: +420-541-147-365; e-mail: salajka.v@fce.vutbr.cz).

numerical model which was used to optimizing the lock structure design. The static test was analyzed using ANSYS program system. After design the structure it was realized full scale crash test of road retaining system using small and very heavy vehicle. Consequently these tests were filled in nonlinear dynamic analysis of impact to road restraint system using LS-DYNA program.

II. STATIC ANALYSIS OF STEEL LOCK OF CRASH BARRIER

The steel lock in a double sided concrete crash barrier is made up from two C shape profiles which are obtained from pipes and 13 profiled steel plates are welded to a C shape profile. A pair of reinforced rods with is welded to every other profiled plate. The cross-section of the connection of crash barriers is “glasses-shaped” and is created by welding two pipes and a plate. The carrying capacity in tension of the lock was assumed to exceed 700kN. In order to perform the carrying capacity test, the lock was assembled using two interconnected parts of the steel lock structure. Two metre long reinforced rods go through holes in the HE 400 B beam. At the ends of the reinforced rods, fillet welds are used to attach the reinforced rods to a steel rod of a full cross-section. The experiment was performed in a horizontal position. Force effects applied on the lock structure were provoked using two parallel connected pressure hydraulic cylinders which were leaned between the steel beams and HE 400 B beams. Resistance tensiometers were attached to the lock structure in five places.

In accordance with the design documentation, a 3D computational test model was created. The model was assembled in the ANSYS program system using exclusively 3D finite elements.

III. EXPERIMENT RESULTS

The measurement showed that the lock failure occurred under the loading of 1.28 MN. The failure occurred in the lower part of the lock, in the first profiled plate.

In this area, a permanent widening of the pipe and a deformation of the profiled plate occurred. In other parts, permanent deformations practically disappeared after the experiment came to an end. As in the other part of the lock the permanent deformations reached only 0.5 mm and given the character of the failure, it is possible to presume that the lock can bear a higher loading. The premature failure in one part of the lock can be attributed to an imperfect weld connecting the pipe and the profiled plate.

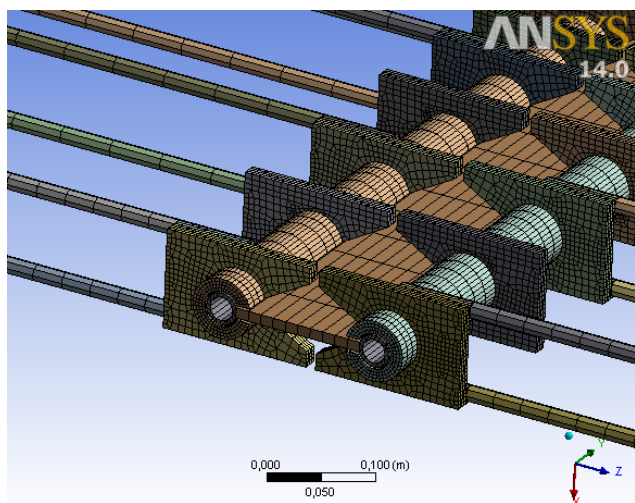

Fig. 1 Detail of computational model of static test



Fig. 2 Lock failure – Experiment

By calculation, a displacement field, a strain field and a stress field for the values of loading of up to 2 MN were obtained. In the first case, the evaluation was carried out only for the levels of loading of 1.275 MN and 1.300 MN. In the other case of loading, a final case after unloading from 1.275 MN was analyzed.

The results obtained by calculation correspond well with the values obtained experimentally. The character of loading and deformations is similar. For nonlinear calculations, bilinear properties of the material based on the mean values of the yield strength and ultimate strength - taking into account ductility - were used. In order to increase the accuracy of the analysis, it would be necessary to perform the tension tests of steel for the lock parts.

The aim of the calculation was not to reach a perfect correspondence with the experiment. The calculation was carried out in order to verify the used material properties and to show that the calculation can fully substitute the experiment

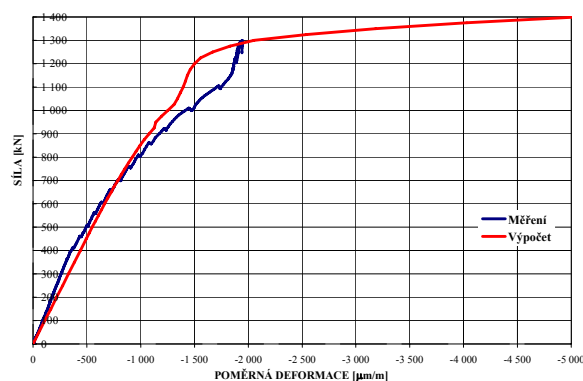

Fig. 3 Measured and calculated values of deformation

IV. FULL SCALE TEST OF BARRIER

After final design of barrier structure it was prepared full scale test according European standards and specific regulation. Full scale test included the impact of light motorcar and height truck to the crash barrier.

The first was an impact of light motorcar with the mass of 900 kg has been selected. The impact of the vehicle on the road restraint system at the speed of 105 km.h⁻¹ under the angle of 30deg has been analyzed.

For the second test of impact to the restraint system was carried out by 30 ton height truck. The speed of the truck was 70 km.h⁻¹. Restraint system after impact avoided of leaving the truck from roadway and the system was not broken as well.



Fig. 4 Impact of light motorcar, speed of impact 105 km.h⁻¹

V. DYNAMIC ANALYSIS OF IMPACT LIGHT MOTOCAR TO THE CRASH BARRIER

The dynamic analysis of impact light motorcar to the crash barrier was using LS-DYNE code was prepared as well. It was prepared the computation model assumes the interaction between the motorcar and crash barrier. Non-linear material properties have been considered for concrete and steel. Deformation behavior of steel has been described assuming bilinear kinematic hardening. This concerns structural elements such as block locking pieces and reinforcing steel bars in blocks. The deformation properties of the concrete of anchoring blocks have been described using a special model developed for the analysis of reinforced concrete crash barriers [1]. The computation model of the vehicle used in the

crash test simulation has been selected from the vehicle database [3]. The complete computation model of the analyzed system is shown in Fig. 6, 7 and 8.

The concrete blocks freely supported on a horizontal plane. Horizontal displacements of blocks are modeled assuming contacts with friction.



Fig. 5 Impact of 30 t height truck, speed of impact 70 km.h^{-1}

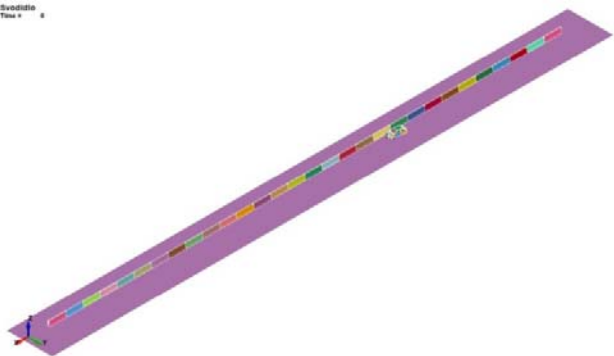

Fig. 6 Computation model - detailed views

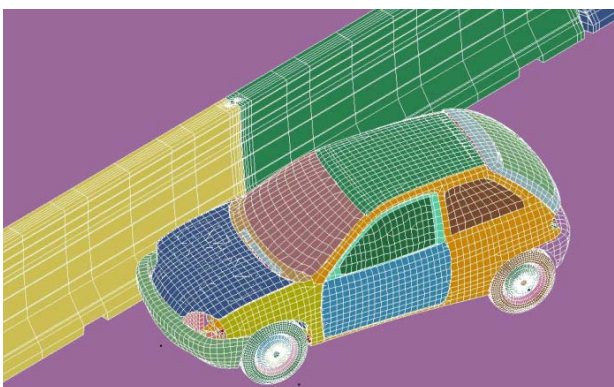

Fig. 7 Computation model - detailed views

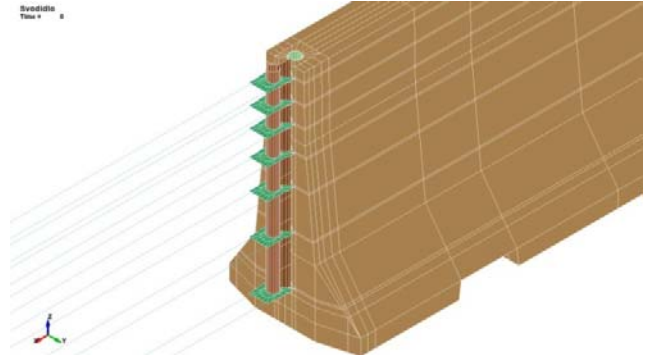

Fig. 8 Computation model - detailed views

The impact of the vehicle on the road restraint system at the speed of 105 km.h^{-1} under the angle of 30° has been analyzed by computer simulation. At the instant of impact, the vehicle contacted the middle of the third anchoring block. The fields of displacements, deformations and stresses of modeled structures have been computed at discrete time instants. Detailed stress analysis of structural elements of joints has been performed. The analysis has shown that the designed structure remains stable during and after the vehicle crash. Maximum stresses appear in block locking piece elements. Another exposed piece is the connection between steel elements of columns and steel elements anchored in concrete. The example of structure crash barriers displacements is displayed on Fig. 9 and Fig. 10 and the field of stresses is observed in steel structural elements is displayed in fig. 11.

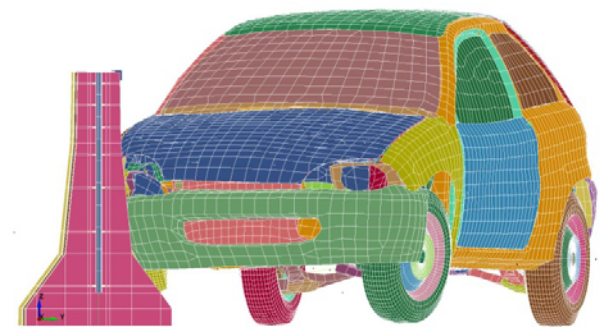

Fig. 9 Impact of motorcar to the barrier at time 0.086 s

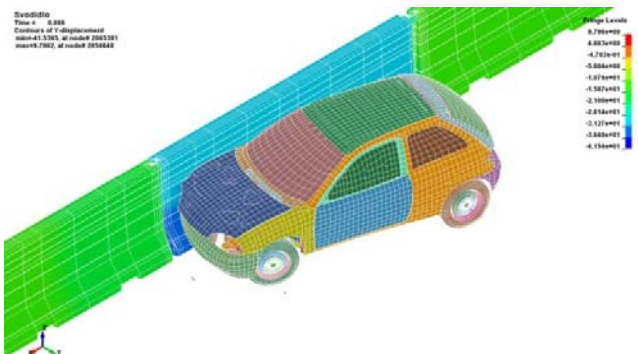

Fig. 10 The field of displacement of barrier

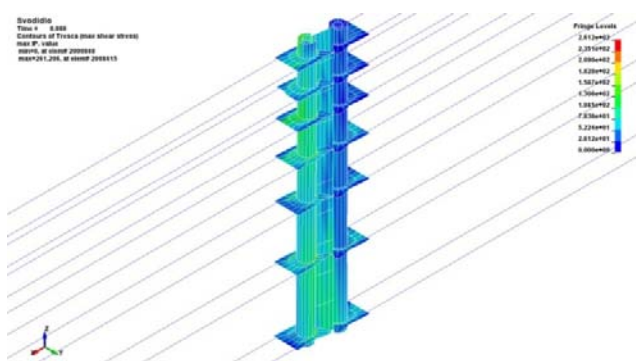

Fig. 11 Field of shear stress in the steel structure of steel joint

VI. CONCLUSION

The impact of a light motorcar on the designed mobile antinoise wall has been analyzed. An advanced detailed non-linear computation model of the mobile antinoise wall has been used. The computation model of the motorcar has been selected from the database of test vehicle models. The analysis has been carried out using a specially developed procedure. The LS-DYNA program package has been applied. The performed computations comply with the technical regulations TP 159 of the Czech Ministry of Transport as well as with the valid design standards. Fulfilling certain specified criteria, the computer analysis substitutes the actual impact test of the vehicle into the restraint system. Following results of computations, construction details of the mobile noise damping wall structure have been properly modified.

ACKNOWLEDGMENT

This outcome has been achieved with the financial support of project GAP104/11/0703 Using progressive materials at structures subjected to cyclic loading and the project MSM0021630519 Progressive and durable civil engineering structures.

REFERENCES

- [1] Y. D. Murray *Theory and Evaluation Concrete Model 159*, 8th International, LS-DYNA Users Conference, Detroit, 2004
- [2] L. E. Schwer, Y. D. Murray *Continuous Surface Cap Model for Geomaterial Modeling: A New LS-DYNA Material Type*, 8th International, LS-DYNA Users Conference, Detroit, 2002.
- [3] European Standard EN-1317 Test Vehicle Models, CM/E Group - Politecnico di Milano, Italy
- [4] TP 159 Guiding walls. Technical specifications, classification, requirements and application. (In Czech: TP 159 Vodící stěny. Technické podmínky, rozřídění vodících stěn, požadavky na vodící stěny, použití), august 2003
- [5] H. Miller, "A note on reflector arrays (Periodical style—Accepted for publication)," *IEEE Trans. Antennas Propagat.*, to be published.
- [6] P. Hradil, V. Salajka, P. Vymlátíl, Assessment of the stability of the mobile antinoise wall. (In Czech: Posouzení stability systému mobilní protihlukové stěny), Technical report, 2009.
- [7] P. Hradil, J. Kala, V. Salajka, P. Vymlátíl *The application of concrete nonlinear model exposed to impact load*, Recent Researches in Automatic Control - 13th WSEAS International Conference on Automatic Control, Modelling and Simulation, ACMOS'11, 2011, Lanzarote, Spain, Pages 283-286, ISBN: 978-161804004-6.
- [8] J. Kala, Z. Kala, J. Melcher, M. Škaloud, Large-deflection-theory analysis of the effect of web initial curvature on the ultimate strength of steel plate girder, Proceedings of the 12th International Conference on Civil, 2009, 10p, Funchal, Madeira, ISBN: 978-190508830-0

- [9] V. Salajka, P. Hradil Test of steel lock of concrete crash barrier height 1.15 m. (In Czech Zkouška ocelového zámku oboustranného betonového svodidla výšky 1.15 m), January 2002.
- [10] ČSN EN 1317 – Road restraint systems
- [11] J. Králik, J. Králik jr. *Seismic Analysis of Reinforced Concrete Frame-Wall Systems Considering Ductility Effects in Accordance to Eurocode. Engineering Structures*. Elsevier 2009, ISSN 0141-0296, Vol.31, Issue 12, pp. 2865 - 2872, December 2009.