

# Two Phase Frictional Pressure Drop of Carbon Dioxide in Horizontal Micro Tubes

M. Tarawneh

**Abstract**—Two-phase frictional pressure drop data were obtained for condensation of carbon dioxide in single horizontal micro tube of inner diameter ranged from 0.6 mm up to 1.6 mm over mass flow rates from  $2.5 \times 10^{-5}$  to  $17 \times 10^{-5}$  kg/s and vapor qualities from 0.0 to 1.0. The inlet condensing pressure is changed from 33.5 to 45 bars. The saturation temperature ranged from  $-1.5$  °C up to 10 °C. These data have then been compared against three (two-phase) frictional pressure drop prediction methods. The first method is by Muller-Steinhagen and Heck (Muller-Steinhagen H, Heck K. A simple friction pressure drop correlation for two-phase flow in pipes. Chem. Eng. Process 1986;20:297–308) and that by Gronnerud R. Investigation of liquid hold-up, flow-resistance and heat transfer in circulation type evaporators, part IV: two-phase flow resistance in boiling refrigerants, Annexe 1972. Then the method used by Friedel. Improved friction pressures drop in horizontal and vertical two-phase pipe flow. European Two-Phase Flow Group Meeting, Paper E2; 1979 June, Ispra, Italy. The methods are used by M.B Ould Didi et al (2001) “Prediction of two-phase pressure gradients of refrigerant in horizontal tubes”. Int.J.of Refrigeration 25(2002) 935-947. The best available method for annular flow was that of Muller-Steinhagen and Heck. It was observed that the peak in the two-phase frictional pressure gradient is at high vapor qualities.

**Keywords**—Two-phase flow, frictional pressure drop, horizontal micro tube, carbon dioxide, condensers.

## I. INTRODUCTION

**P**REDICTION of two-phase frictional pressure drops during the condensation of two-phase flow refrigerants is important for accurate design and optimization of refrigeration, air-conditioning and heat pump systems. Associated with the compactness resulted from the use of CO<sub>2</sub> as working fluid, the use of the micro tube technology (tubes having diameter of less than 3 mm) in the heat exchangers design yields a very compact and lightweight equipments. The high heat transfer coefficients and significant potential in decreasing the heat exchanger surface area are the major advantages of using this kind of geometry. For these reasons micro tube heat exchangers have been used in bioengineering and microelectronics as well as in evaporators and condensers of refrigeration systems. The optimal use of the two-phase pressure drop during the condensation of refrigerants to obtain the maximum heat transfer performance is one of the primary design goals. Also, the accurate prediction of two-phase pressure drops is a particularly important aspect of the first and second law optimizations of these systems. Yun and Kim

M. Tarawneh is an Assistant Professor, Mechanical engineering department The Hashemite University, Zarqa 13115 Jordan, (tel: +962 5 390 3333, fax: +962 5 390 3338, e-mail: mtar413@yahoo.com).

[1] investigated two-phase pressure drops of CO<sub>2</sub> in mini tubes with inner diameters of 2.0 and 0.98 mm and in micro channels with hydraulic diameters from 1.08 to 1.54 mm. The pressure drop of CO<sub>2</sub> in the mini tubes shows very similar trends with those in large diameter tubes. Huai et al. [2] presented experimentally a study of boiling heat transfer and pressure drop of CO<sub>2</sub> flowing in a multi-port extruded aluminum test section, which had 10 circular channels, each with an inner diameter of 1.31 mm. The results indicated that pressure drop along the test section is very small. Ould Didi et al [3] studied the prediction of two-phase pressure gradients of refrigerants during evaporation in horizontal tubes of more than 10 mm diameter for different mass velocities and different vapor qualities. The resulted experimental data have then been compared against seven two-phase frictional pressure drop prediction methods. Kattan et al [4] studied the flow boiling in horizontal tubes through the development of an adiabatic two phase flow pattern map. Moreno Quibén, J., Thome, J. R. [5] presented a flow pattern based two-phase frictional pressure drop model for horizontal tubes through an adiabatic experimental study. In the present study, experimental test data resulted from the condensation of CO<sub>2</sub> in horizontal copper micro tubes under the effect of free convection inside a chest freezer have been compared to the following three widely quoted prediction methods for the frictional pressure drop in two-phase flows: Friedel [6], Gronnerud [7], and Muller-Steinhagen and Heck [8]. The two-phase pressure drop tests cover three different tube diameters (0.6, 1 and 1.6 mm) with total length of 29.72 m over mass flow rates from  $2.5 \times 10^{-5}$  to  $17 \times 10^{-5}$  kg/s for saturation pressures ranging from 33.5 to 45 bars and saturation temperature ranged from ( $-1.5$  °C up to 10 °C). The comparisons were based mainly on the variation of the vapor quality with the frictional pressure drop for different inlet pressures, different mass flow rates, different saturation temperatures and different tube diameters.

### A. Nomenclature

- a parameter in Eq. (36) (Pa m<sup>1</sup>)
- b parameter in Eq. (36) (Pa m<sup>1</sup>)
- B parameter of Chisholm
- C constant of Lockhart and Martinelli (m)
- d<sub>i</sub> tube internal diameter
- E parameter of Friedel
- F parameter of Friedel
- f friction factor
- f<sub>Fr</sub> Froude friction factor
- g acceleration due to gravity (m s<sup>-2</sup>)

- G factor in Eq. (36) (Pa m<sup>1</sup>)  
 H factor of Friedel  
 L tube length (m)  
 :m<sub>total</sub> total mass velocity of liquid plus vapor  
 n exponent (kg m<sup>2</sup> s<sup>1</sup>)  
 p pressure (Pa)  
 dp/dz frictional pressure gradient (Pa m<sup>1</sup>)  
 A<sub>ptotal</sub> total pressure drop (Pa)  
 A<sub>pstatic</sub> static head pressure drop (Pa)  
 A<sub>pmom</sub> two-phase momentum pressure drop (Pa)  
 A<sub>pfriact</sub> two-phase frictional pressure drop (Pa)  
 A<sub>pG</sub> vapor-phase pressure drop (Pa)  
 A<sub>pL</sub> liquid-phase pressure drop (Pa)  
 T<sub>sat</sub> saturation temperature (°C)  
 X<sub>tt</sub> Martinelli parameter  
 Y Chisholm parameter
- Greek Symbols  
 x vapor quality  
 E vapor void fraction  
 p density (kg m<sup>3</sup>)  
 L<sub>o</sub> two-phase multiplier for liquid only  
 G<sub>o</sub> two-phase multiplier for vapor only  
 L<sub>tt</sub> two-phase multiplier of Martinelli relative to liquid  
 G<sub>tt</sub> two-phase multiplier of Martinelli relative to vapor  
 gd two-phase multiplier of Gronnerud dynamic viscosity (N s m<sup>2</sup>)  
 a surface tension (N m<sup>1</sup>)
- Dimensionless numbers  
 Fr Froude number  
 Re Reynolds number  
 We Weber number

### Subscripts

- G vapor or gas  
 G<sub>o</sub> vapor only (all flow as vapor)  
 h homogeneous  
 L liquid  
 L<sub>o</sub> liquid only (all flow as liquid)  
 tp two-phase

## II. TWO-PHASE FRICTIONAL PRESSURE DROP

The total two-phase pressure drop for flows inside micro tubes is the sum of the static pressure drop ( $\Delta P_{static}$ ), the momentum pressure drop ( $\Delta P_{mom}$ ) and the frictional pressure drop ( $\Delta P_{frict}$ ) and it is represented as follows:

$$\Delta P_{total} = \Delta P_{static} + \Delta P_{mom} + \Delta P_{frict} \quad (1)$$

There is no change in static head for a horizontal tube, so ( $\Delta P_{static} = 0$ ). The momentum pressure drop reflects the change in kinetic energy of the flow and is for the present case given by:

$$\Delta P_{mom} = \dot{m}_{total}^2 \left\{ \left[ \frac{(1-x)^2}{\rho_L(1-\varepsilon)} + \frac{x^2}{\rho_G \varepsilon} \right]_{out} - \left[ \frac{(1-x)^2}{\rho_L(1-\varepsilon)} + \frac{x^2}{\rho_G \varepsilon} \right]_{in} \right\} \quad (2)$$

where  $m_{total}$  is the total mass velocity of liquid plus vapor and  $x$  is the vapor quality. In the present study, the void function  $\varepsilon$  is obtained from Ould Didi et al [3] version of the drift flux model of Rouhani and Axelsson [9] for horizontal tubes:

$$\varepsilon = \frac{x}{\rho_G} \left[ \left( 1 + 0.12(1-x) \right) \left( \frac{x}{\rho_G} + \frac{1-x}{\rho_L} \right) + \frac{1.18(1-x) [g\sigma(\rho_L - \rho_G)]^{0.25}}{\dot{m}_{total}^2 \rho_L^{0.5}} \right]^{-1} \quad (3)$$

Hence, the experimental two-phase frictional pressure drop is obtainable from equation (1) by Subtracted the calculated momentum pressure drop from the measured total pressure drop.

## III. LITERATURE TWO-PHASE FRICTIONAL PRESSURE DROP

The following three literature two-phase frictional pressure drop correlations are compared to the present experimental data:

### A. Friedel Correlation [6]

This method is for vapor qualities from  $0 \leq x < 1$  and utilizes a two-phase multiplier as:

$$\Delta p_{frict} = \Delta p_L \phi_{L_o}^2 \quad (4)$$

where  $\Delta p_L$  is calculated for the liquid-phase as:

$$\Delta p_L = 4f_L(L/D_i) \dot{m}_{total}^2 (1-x)^2 (1/2\rho_L) \quad (5)$$

The liquid friction factor and liquid Reynolds number are obtained from

$$f = \frac{0.079}{Re^{0.25}} \quad (6)$$

$$Re = \frac{\dot{m}_{total} D_i}{\mu} \quad (7)$$

Using the liquid dynamic viscosity ( $\mu_L$ ), his two-phase multiplier is correlated as:

$$\phi_{L_o}^2 = E + \frac{3.24FH}{Fr_h^{0.045} We_L^{0.035}} \quad (8)$$

where  $Fr_h$ , E, F and H are as follows:

$$Fr_h = \frac{\dot{m}_{total}^2}{g d_i \rho_h^2} \quad (9)$$

$$E = (1-x)^2 + x^2 \frac{\rho_L f_G}{\rho_G f_L} \quad (10)$$

$$F = x^{0.78} (1 - x)^{0.224} \quad (11)$$

$$H = \left(\frac{\rho_L}{\rho_G}\right)^{0.91} \left(\frac{\mu_G}{\mu_L}\right)^{0.19} \left(1 - \frac{\mu_G}{\mu_L}\right)^{0.7} \quad (12)$$

The liquid Weber ( $We_L$ ) is defined as:

$$We_L = \frac{\dot{m}_{total}^2 D_i}{\sigma \rho_h} \quad (13)$$

and the homogeneous density  $\rho_h$  is used:

$$\rho_h = \left(\frac{x}{\rho_G} + \frac{1-x}{\rho_L}\right)^{-1} \quad (14)$$

Friedel's method is typically, recommended when the ratio of  $(\mu_L/\mu_G)$  is less than 1000.

#### B. Gronnard Correlation [7]

This method was developed specifically for refrigerants and it is represented as follows:

$$\Delta p_{frict} = \varphi_{gd} \Delta p_L \quad (15)$$

and

$$\varphi_{gd} = 1 + \left(\frac{dp}{dz}\right)_{Fr} \left[ \frac{\left(\frac{\rho_L}{\rho_G}\right)}{\left(\frac{\mu_L}{\mu_G}\right)^{0.25}} - 1 \right] \quad (16)$$

where,  $E_q(5)$  is used for  $\Delta p_L$  and his two face multiplier is a function of;

$$\left(\frac{dp}{dz}\right)_{Fr} = f_{Fr} [x + 4(x^{1.8} - x^{10} f_{Fr}^{0.5})] \quad (17)$$

If the liquid Froude number  $Fr_L$  is greater than or equal to 1, then the friction factor  $f_{Fr}$  is set to 1.0; if  $f_{Fr}$  is less than 1, then:

$$f_{Fr} = Fr_L^{0.3} + 0.0055 \left(\ln \frac{1}{Fr_L}\right)^2 \quad (18)$$

where

$$Fr_L = \frac{\dot{m}_{total}^2}{g d_i \rho_L^2} \quad (19)$$

The correlation of Gronnerud is applicable to vapor qualities from  $0 \leq x \leq 1$ .

#### C. Muller-Steinhagen and Heck Correlation

This two-phase frictional pressure gradient correlation is represented as follows:

$$\left(\frac{dp}{dz}\right)_{frict} = G(1 - x)^{1/3 + bx^3} \quad (20)$$

where the factor G is

$$G = a + 2(b-a)x \quad (21)$$

where a and b are the frictional p reasure gradients for all the flow liquid  $(dp/dz)_{Lo}$  and all the flow vapor  $(dp/dz)_{Go}$  which are obtained respectively from the following two equations:

$$\left(\frac{dp}{dz}\right)_{Lo} = f_L \frac{2\dot{m}_{total}^2}{d_{i\rho L}} \quad (22)$$

$$\left(\frac{dp}{dz}\right)_{Go} = f_G \frac{2\dot{m}_{total}^2}{d_{i\rho G}} \quad (23)$$

This model is essentially an empirical two-phase extrapolation between all liquid flow and all vapor flow and as such is applicable for  $0 \leq x \leq 1$ . Recently, Tribbe C. and Muller-Steinhagen [10] have shown that this method gave the best results from a comparison of competing methods against a database covering air-oil, air-water, water-steam and several refrigerants.

## IV. EXPERIMENTS

### A. Experimental Conditions

The condensation process of CO<sub>2</sub> gas is performed inside a selected single micro tube heat exchanger. The experimental conditions were determined and heat exchangers were fabricated according to the specifications listed in Table I.

TABLE I  
EXPERIMENTAL CONDITIONS

Test section	Micro pipe condenser
Process	Condensation inside a chest freezer of -28 °C
Working fluid	CO <sub>2</sub>
Inner tube diameter (mm)	0.6, 1.0, 1.6
Total tube length (m)	29.72
Test section inlet pressure (kPa)	3350, 3600, 4000, 4500
Saturation temperature (°C)	-1.5, 1.23, 5.30, 9.98
Mass flow rate	(2.66, 5.32, 8, 10.6)*10 <sup>-5</sup> kg/s

### B. Experimental Setup

The schematic diagram of the test apparatus and its main components is shown in Fig. 1. The experimental set-up consists basically of the condenser and the evaporator (test sections), chest freezer, the pressurized carbon dioxide gas cylinder as a main source of carbon dioxide gas, high pressure regulating valve with built-in gas cylinder pressure gauges, sight glasses, pressure transducers, high pressure cutoff and isolating valves and a volume flow meter for measuring the mass flow rate of the gas. The temperatures and pressures at different location of the condenser are measured and monitored by using data acquisition system, computer and printer.

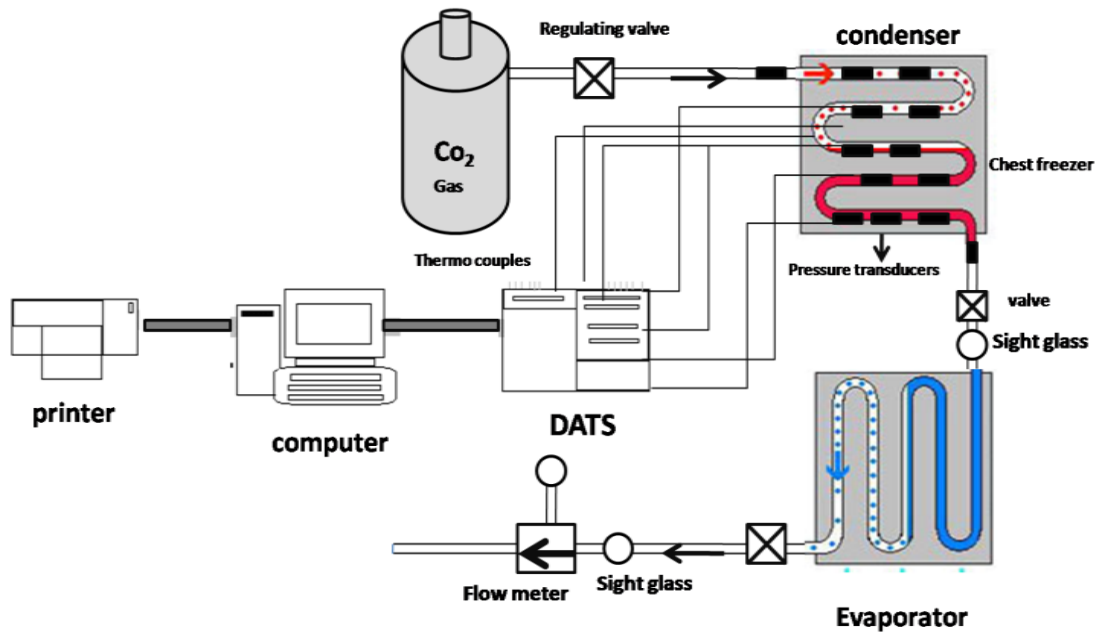

Fig. 1 Tests Apparatus

### C. Experimental Test Sections and Measurement Method

The test data were obtained for condensing conditions inside horizontal copper micro tube of 29.72 m length settled in a chest freezer with inside temperature of  $-28^{\circ}\text{C}$ . The surface temperatures of the micro tube were measured by using K-Type thermocouples located at 32 points distributed along the tube. The two phase pressure drops were measured by using 10 differential pressure transducers located along the micro tube each had an accuracy of 0.3% and they were calibrated in the laboratory before use. Data Acquisition System with computer display was used to record and monitor the surface temperature and the local pressure readings at different positions along the micro tube after a steady state conditions are achieved. The inlet and outlet pressures of the test sections were measured by using differential pressure transducers. The flow rate of the super heated refrigerant at the exit of the evaporator is measured by using Coriolis flow meter which was calibrated in the laboratory with accuracy of 0.3% of the reading. Two sight glasses are used to monitor the presence of vapor ( $x=0$ ) and liquid ( $x=1$ ) at the inlet and the outlet of the condenser. Another third sight glass is located at the exit of the evaporator to monitor the presence of only vapor without any droplets of the refrigerant. The physical properties of the refrigerant were obtained using the REFPROP [11]. The local qualities of the vapor were obtained from energy balance inside the micro tube depending on the experimental local pressures which are determined from the readings of the pressure transducers. The measured two phase pressure drops are combination of the frictional pressure drop and the momentum pressure drop of the condensing  $\text{CO}_2$  gas. Hence, the momentum pressure drop was calculated using the inlet, outlet and local qualities together with equations (2) and (3) and subtracting the value from the measured pressure drop

to obtain the frictional pressure drop. Licensed LABVIEW software is used to analyze the data during the experimental tests.

## V. RESULTS AND DISCUSSION

### A. Effect of Mass Flow Rate and Pipe Diameter on the Total and Frictional Pressure Gradients

The variation of the total condenser pressure drop versus the mass flow rate for  $P_{in} = 33500\text{ kPa}$  and different internal diameters is shown in Fig. 2 and 3. It can be noticed from these figures that the pressure drop increases as the mass flow rate increases and it decreases as the internal micro tube diameter increases. This is due to the increase of liquid viscosity and the decrease of vapor density.

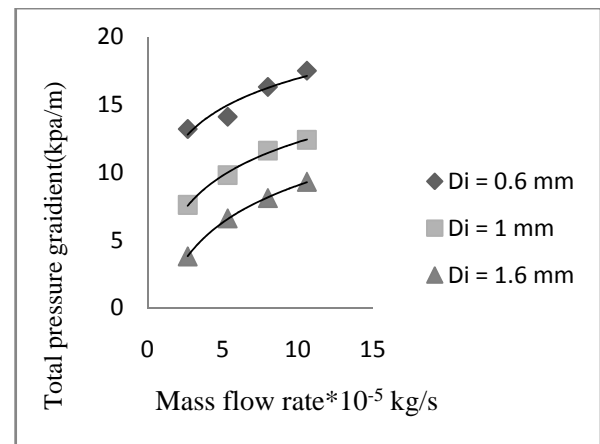

Fig. 2 Effect of mass flow rate on the total experimental pressure gradient

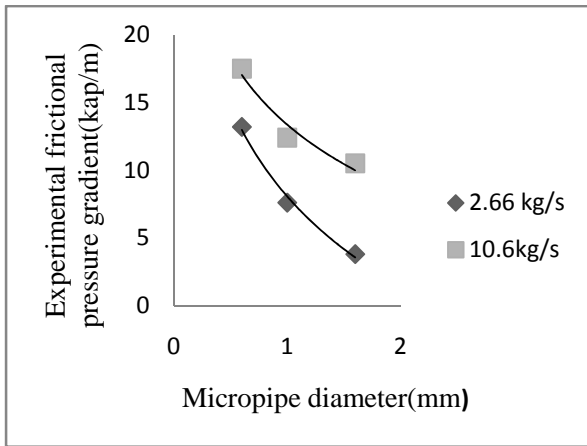

Fig. 3 Micro pipe (Di) Diameter versus frictional pressure gradient for different mass flow rates and  $P_i = 3350$  kpa

### B. Effect of Vapor Quality And Pipe Diameter on the Frictional Pressure Gradient

The experimental frictional pressure drops were obtained according to equations (1), (2) and (3) for all test sections and experimental conditions depending on the experimental local pressure readings and the associated vapor qualities along the test sections. The experimental frictional pressure drops were then converted into frictional pressure gradients by dividing by the test section length and then it have been compared to all three methods described earlier. The predicted frictional pressure gradient for different experimental situations is depicted graphically as show below.

Fig. 4, 5 and 6 depict the  $CO_2$  data in the (0.6, 1 and 1.6 mm) micro tubes at mass flow rate of  $2.66 \times 10^{-5}$  kg/s and inlet pressure of 3350 kpa for the three different prediction methods. It can be noticed from these figures that the predicted values of the frictional pressure gradient go through a maximum at a vapor quality of 0.8, which corresponds to the transition from annular flow to annular flow with partial dry out (i.e. annular flow to stratified-wavy flow transition) predicted by the Kattan et al [4] flow pattern map. The three figures show that as the vapor quality increases the predicted frictional pressure gradient increases and it decreases as the tube diameter increases.

Fig. 7, 8 and 9 depicts the  $CO_2$  data in the three different diameter tubes at mass flow rate of  $2.66 \times 10^{-5}$  kg/s and inlet pressure of 3350 kpa. The figures compare the experimental frictional pressure gradients with predicted values from the three different prediction methods. It is clear also for these figures that Muller's method [8] gives the best prediction of the frictional pressure drop. Gronnerd method comes secondly in fitting the experimental frictional pressure gradient.

Fig. 10 shows the variation of the experimental frictional pressure gradient with the vapor quality for different micro tube diameters at mass flow rate of  $2.66 \times 10^{-5}$  kg/s and inlet pressure of 3350 kpa. It can be noticed from this figure that the experimental values of the frictional pressure gradient go through a maximum at a vapor quality of 0.8 the same as that of the predicted values. It is clear from this figure that the

maximum value of the experimental frictional pressure drop is reached at  $D_i = 0.6$  mm and vapor quality of 0.8.

Fig. 11 depicts the  $CO_2$  data for  $D_i = 0.6$  mm at mass flow rate of  $8 \times 10^{-5}$  kg/s and inlet pressure of 3350 kpa. It can be noticed from this figure that the experimental and the predicted pressure gradient are sharply increased due to the increase in mass flow rate in comparison with its values in Figs 7, 8, 9 at which the mass flow rate is  $2.66 \times 10^{-5}$  kg/s. Muller's method is still the best fit to the experimental frictional pressure drop values with maximum pressure drop at about 0.8 vapor quality.

Fig. 12 depicts the  $CO_2$  data for  $D_i = 1.6$  mm at mass flow rate of  $2.66 \times 10^{-5}$  kg/s and inlet pressure of 3350 kpa. It can be noticed from this figure that the experimental and the predicted pressure gradient are sharply decreased due to the increase in micro tube diameter in comparison with its values in Fig. 7, 8, 9 at which the micro tube diameter  $D_i$  is 0.6 mm. Muller's method is still the best fit to the experimental frictional pressure drop values with maximum pressure drop at about 0.8 vapor quality.

In Fig. 13, 14, 15 and 16, the predicted frictional pressure gradients are plotted against the experimental frictional pressure gradients for different mass flow rates, different tube diameters and for inlet pressure of 3350 kpa. It is clear from these four figures that the three prediction methods fit the experimental data but with different average standard deviation ranged from 6.4% to Muller method till 12.1% to Gronnerd method and then 17.3 to Friedel method.

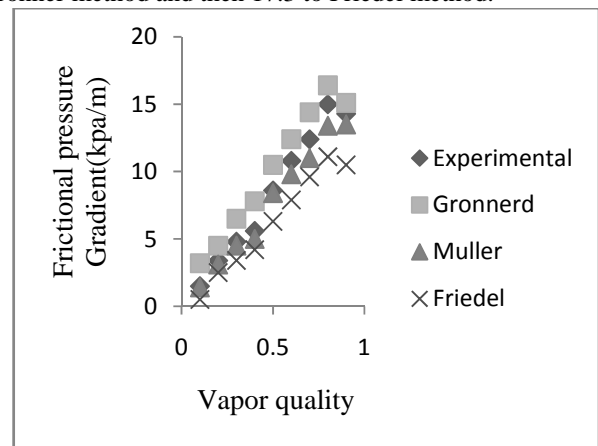

Fig. 4 Vapor quality versus Friedel pressure gradient for different  $D_i$ , mass flow rate =  $2.66 \times 10^{-5}$  kg/s and  $P_i = 3350$  kpa

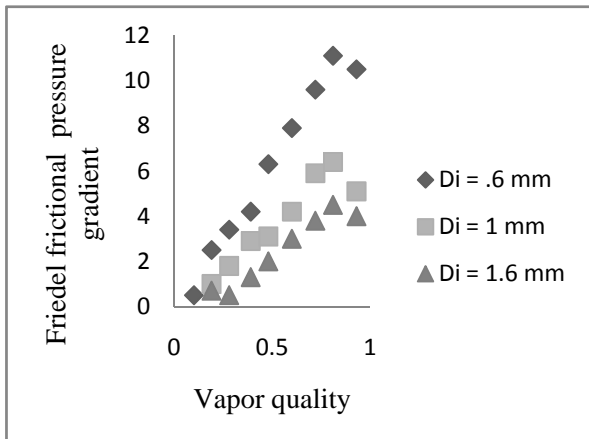

Fig. 5 Vapor quality versus Gronnard pressure gradient for different Di, mass flow rate  $=2.66 \cdot 10^{-5}$  kg/s and Pi = 3350 kpa

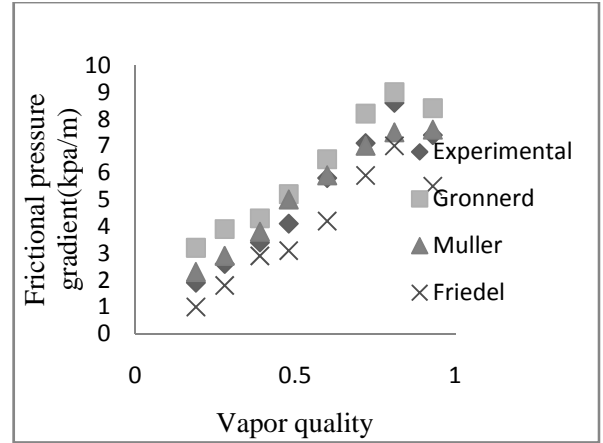

Fig. 8 Effect of vapor quality on the pressure gradient for Di = 1 mm and mass flow rate  $=2.66 \cdot 10^{-5}$  kg/s and Pi = 3350 kpa

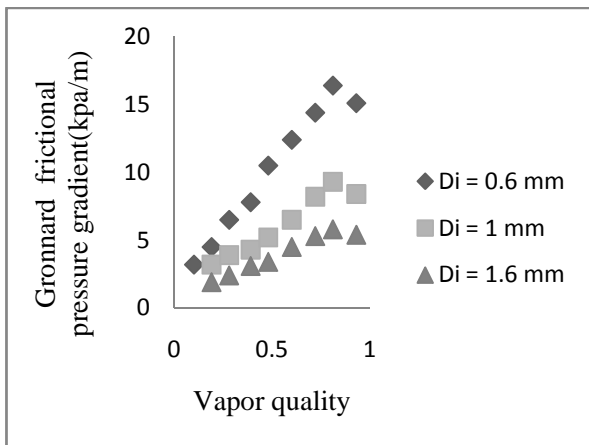

Fig. 6 Vapor quality versus Muller pressure gradient for different Di, mass flow rate  $=2.66 \cdot 10^{-5}$  kg/s and Pi = 3350 kpa

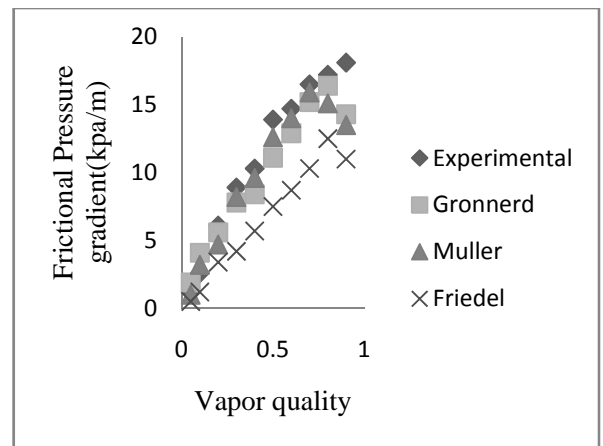

Fig. 9 Effect of vapor quality on the pressure gradient for Di = 1 mm and mass flow rate  $=5.32 \cdot 10^{-5}$  kg/s and Pi = 3350 kpa

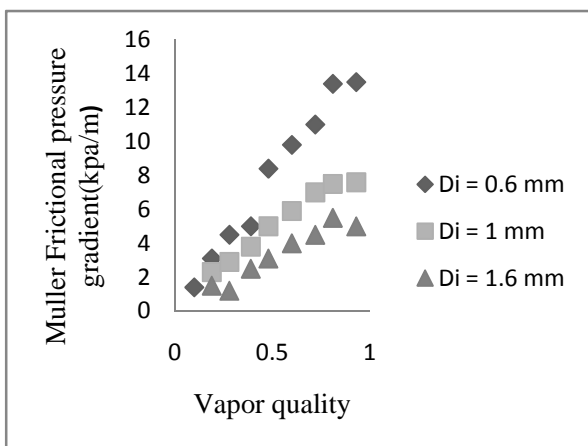

Fig. 7 Effect of vapor quality on the pressure gradient for Di = 0.6 mm and mass flow rate  $=2.66 \cdot 10^{-5}$  kg/s

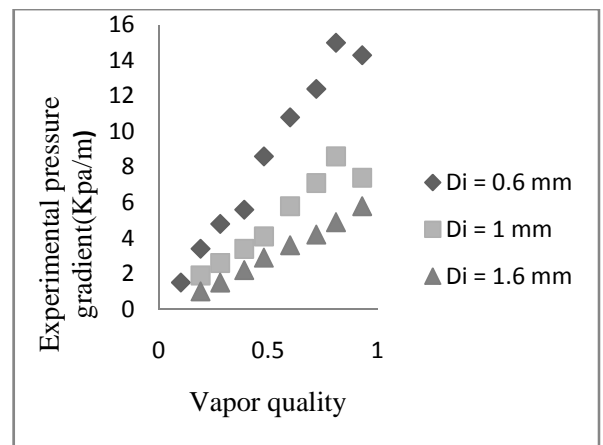

Fig. 10 Effect of vapor quality on the pressure gradient different Di, mass flow rate  $=2.66 \cdot 10^{-5}$  kg/s and Pi = 3350 kpa

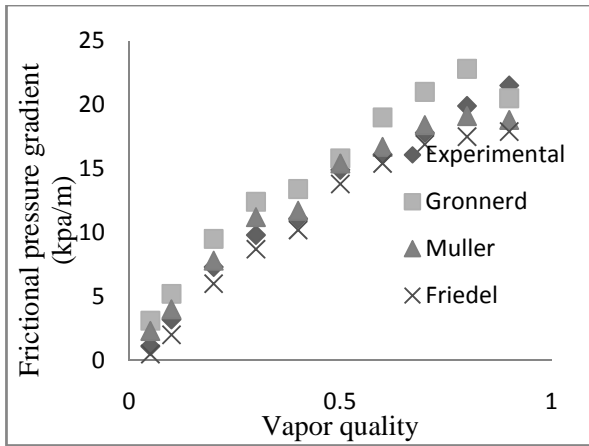

Fig. 11 Effect of vapor quality on the pressure gradient for  $D_i = 0.6$  mm and mass flow rate  $= 8 \cdot 10^{-5}$  kg/s and  $P_i = 3350$  kpa

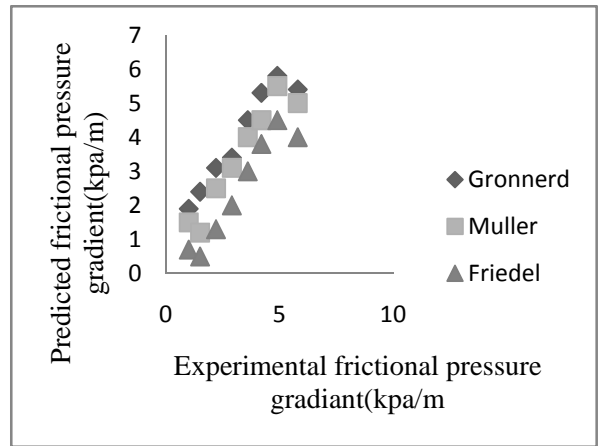

Fig. 14 Experimental frictional versus Predicted frictional pressure gradients for different methods, mass flow rate  $= 2.66 \cdot 10^{-5}$  kg/s .  $D_i = 1.6$  mm and  $P_i = 3350$  kpa

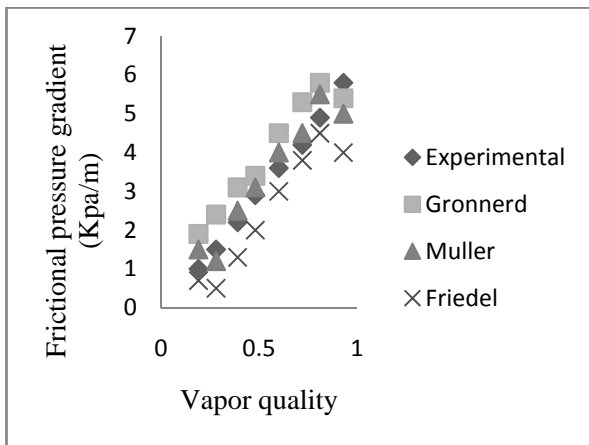

Fig. 12 Effect of vapor quality on the pressure gradient for  $D_i = 1.6$  mm and mass flow rate  $= 2.66 \cdot 10^{-5}$  kg/s and  $P_i = 3350$  kpa

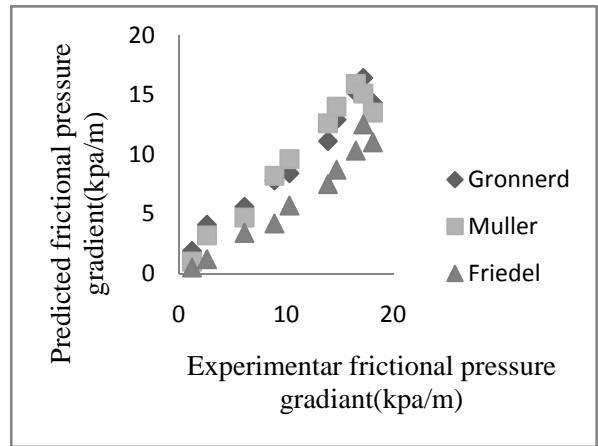

Fig. 15 Experimental frictional versus Predicted frictional pressure gradients for different methods, mass flow rate  $= 5.32 \cdot 10^{-5}$  kg/s .  $D_i = 0.6$  mm and  $P_i = 3350$  kpa

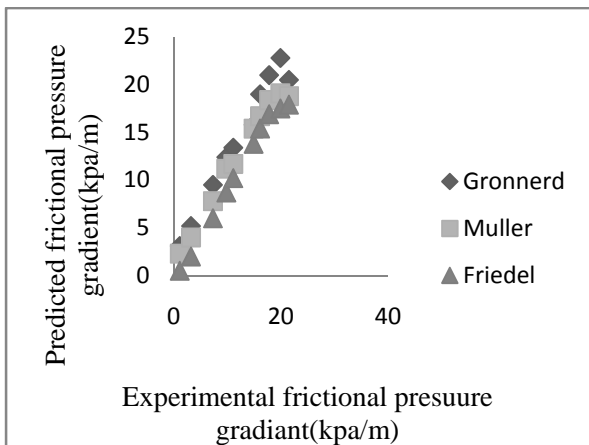

Fig. 13 Experimental frictional versus Predicted frictional pressure gradients for different methods, mass flow rate  $= 8 \cdot 10^{-5}$  kg/s .  $D_i = 0.6$  mm and  $P_i = 3350$  kpa

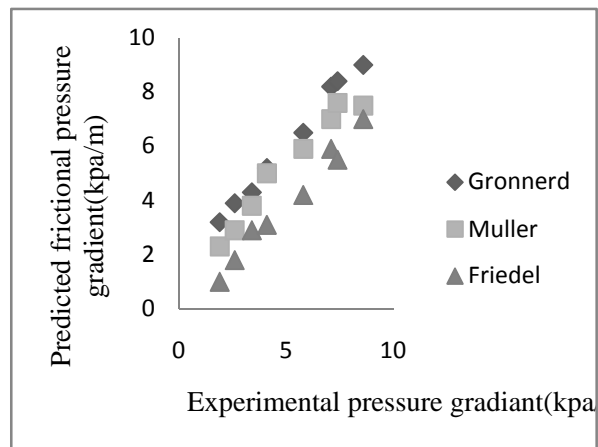

Fig. 16 Experimental frictional versus Predicted frictional pressure gradients for different methods, mass flow rate  $= 2.66 \cdot 10^{-5}$  kg/s .  $D_i = 1$  mm and  $P_i = 3350$  kpa

## VI. CONCLUSIONS

1. Three different prediction methods based on the vapor quality of the refrigerant were used to predict the frictional pressure drop during the condensation of carbon dioxide in micro tubes. The Muller method gave the best fit while Gronnerd and Friedel methods gave the second and the third best with average standard deviations of 6.4%, 12.1% and 17.3% respectively.
2. The peak two phase frictional pressure gradient of CO<sub>2</sub> was observed at high vapor qualities.
3. The two phase frictional pressure gradient of CO<sub>2</sub> increased as the micro pipe diameter decreased and it increased as the mass flow rate increased

## REFERENCES

- [1] Yun, R. and Kim, Y. (2004). Two-phase pressure drops of CO<sub>2</sub> in mini tubes and microchannels. *Microscale Thermophysical Engineering*, 8(3), 259 – 270.
- [2] Huai, X., Koyama, S., Zhao, T.S., Shimura, E., Hidehiko, K. and Masaki, M. (2004). An experimental study of flow boiling characteristics of carbon dioxide in multiport mini channels. *Applied Thermal Engineering*, 24, 1443–1463.
- [3] Ould Didi. M. B, Kattan. N, Thome. J. R. 2002. Prediction of Two Phase Pressure Gradients of Refrigerants in Horizontal Tubes. *Int. J. Refrigeration*. 25: 935-947.
- [4] Kattan N., Thome J. R., Favrat D. 1998. Flow boiling in horizontal tubes: Part I- Development of diabatic two phase flow pattern map. *J. of Heat Transfer*. 120: 140-147.
- [5] Moreno Quibén. J., Thome. J. R. 2007. Flow Pattern Based Two-Phase Frictional Pressure Drop Model for Horizontal Tubes, Part I: Diabatic and Adiabatic Experimental Study. *Int. J. Heat Fluid Flow*. 28(5):1049-1059.
- [6] Friedel L. 1979. Improved friction pressure drop correlations for horizontal and vertical two phase pipe flow. Paper E2, European Two Phase Flow Group Meeting, Ispra, Italy.
- [7] Grönnerud R. 1979. Investigation of liquid hold-up, flow-resistance and heat transfer in circulation type of evaporators, part IV: two-phase flow resistance in boiling refrigerants. In: *Annexe1972-1, Bull. Del'Inst. du Froid*.
- [8] Müller-Steinhagen. H., Heck. K. 1986. A Simple Friction Pressure Drop Correlation for Two-Phase Flow in Pipes. *Chem. Eng. Process*, 20: 297-308.
- [9] Rouhani Z, Axelsson E. Calculation of void volume fraction in the sub cooled and quality boiling regions. *Int J Heat Mass Transfer* 1970; 13:383–93.
- [10] Tribbe C, Muller-Steinhagen H. An evaluation of the performance of phenomenological models for predicting pressure gradient during gas-liquid flow in horizontal pipelines. *Int. J Multiphase Flow* 2000 (26) 1019–36.
- [11] Refprop. Nist Refrigerant Properties Database 23, Gaithersburg, MD, 1998, Version 6.01.