

Pressure Swing Adsorption with Cassava Adsorbent for Dehydration of Ethanol Vapor

Chontira Boonfung and Panarat Rattanaphanee

Abstract—Ethanol has become more attractive in fuel industry either as fuel itself or an additive that helps enhancing the octane number and combustibility of gasoline. This research studied a pressure swing adsorption using cassava-based adsorbent prepared from mixture of cassava starch and cassava pulp for dehydration of ethanol vapor. The apparatus used in the experiments consisted of double adsorption columns, an evaporator, and a vacuum pump. The feed solution contained 90-92 %wt of ethanol. Three process variables: adsorption temperatures (110, 120 and 130°C), adsorption pressures (1 and 2 bar gauge) and feed vapor flow rate (25, 50 and 75 % valve opening of the evaporator) were investigated. According to the experimental results, the optimal operating condition for this system was found to be at 2 bar gauge for adsorption pressure, 120°C for adsorption temperature and 25% valve opening of the evaporator. Production of 1.48 grams of ethanol with concentration higher than 99.5 wt% per gram of adsorbent was obtained. PSA with cassava-based adsorbent reported in this study could be an alternative method for production of nearly anhydrous ethanol. Dehydration of ethanol vapor achieved in this study is due to an interaction between free hydroxyl group on the glucose units of the starch and the water molecules.

Keywords—Adsorption, PSA, Ethanol, Dehydration, Cassava.

I. INTRODUCTION

WATER adsorption is one of energy-efficient techniques that are widely used for dehydration of ethanol, and starchy and cellulosic biomass are among several adsorbents that have been used for this purpose. Examples of the biomass-derived adsorbents include cracked corns [1], corn meal [2]-[4], corn grits [5], [6], xylan and wood chips [7], [8], wheat constituents [9], [10], natural corncobs, natural and activated palm stone and oak [11]. These materials offers several advantages that have led to growing interest in using them as potent desiccants for drying gaseous and organic compounds. For example, adsorption with biomass-derived adsorbent was reported to be less energy-consuming than adsorption using other adsorbents. The total energy consumed in dehydration of ethanol using cellulose was reported to be 2,873 kJ/kg_{ethanol}, while the adsorption using calcium oxide (CaO) was 3,669 kJ/kg_{ethanol} [1]. Also, biomass-derived adsorbents were found to need less energy for regeneration

than synthetic adsorbents [12]. Another advantage is that when regeneration is not practical for the spent adsorbents, they could be used as a feedstock of fermentation, either for ethanol or biogas production. In addition, deposition of starch and cellulose base adsorbent is unproblematic and environmental friendly due to their readily biodegradability.

Ability of starch and cellulose in selectively adsorption of water is a result of interaction in the form of hydrogen bonding between free hydroxyl groups (-OH) on their glucose units and the water molecules [13]. Water is by nature more polar than organic compounds such as alcohols; therefore, it interacts with hydroxyl groups of the glucose-containing adsorbent with higher strength and faster rate. Consequently, aqueous alcohol solution passing through bed of starchy or cellulosic materials would come out with lower concentration of water in the solution.

Wet cassava pulp is cellulosic material that is normally created abundantly during the production of cassava starch in Thailand. This material is usually sold very cheaply at 100-400 Baths/ton (about \$3-\$12/ton), to animal feed manufacturers. When the demand from animal feed industry is low, cassava pulp accumulates and rots, causing an extremely unpleasant smell, which is an environmental problem commonly encountered in the area around cassava starch factories.

Capability of biomass adsorbent prepared from cassava pulp, which still contains sufficient amount of starch, was used successfully in packed-bed adsorption system dehydration of ethanol vapor [14]. In this study, water adsorption capacity of the adsorbent is tested in pressure swing adsorption. Effect of operating variables including adsorption temperature and pressure as well as feed flow rate on ethanol concentration in the products and ethanol production rate was investigated.

II. MATERIALS AND METHODS

A. Cassava Starch and Cassava Pulp

Cassava starch and dried ground cassava pulp were weighed and mixed with an addition of 0.1 M NaOH. The mixture was stirred while being heated at temperature about 65°C for 10 min. The mixture was then spread out on an aluminum pan and was dried for 12 h in the hot air oven at 110°C. The dried mixture was then ground and sieved, and pellets with size between 30-40 Mesh were used as the adsorbent in this study.

C. Boonfung and is with School of Chemical Engineering, Suranaree University of Technology, Nakhon Ratchasima, Thailand 30000 (e-mail: chontira_b@hotmail.com).

P. Rattanaphanee is with School of Chemical Engineering, Suranaree University of Technology, Nakhon Ratchasima, Thailand 30000 (corresponding author to provide phone: +66-44-224591; fax: +66-44-224609; panarat@sut.ac.th).

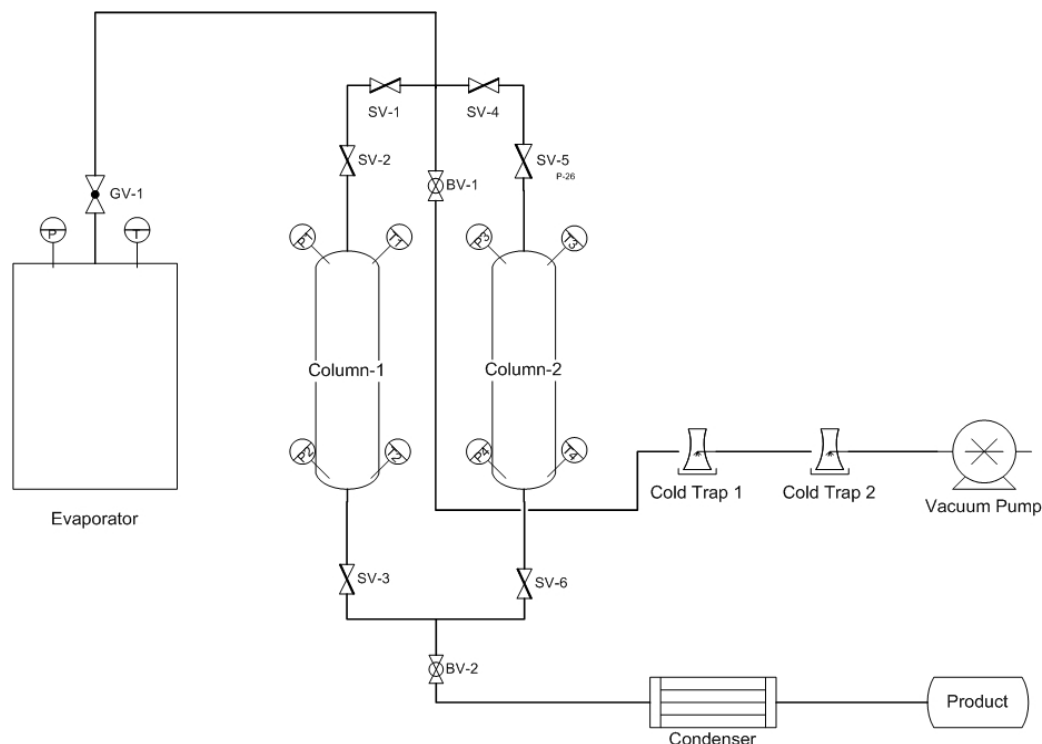

Fig. 1 Schematic diagram of PSA process

B. Adsorbent Preparation

Cassava starch and dried ground cassava pulp were weighed and mixed with an addition of 0.1 M NaOH. The mixture was stirred while being heated at temperature about 65°C for 10 min. The mixture was then spread out on an aluminum pan and was dried for 12 h in the hot air oven at 110°C. The dried mixture was then ground and sieved, and pellets with size between 30-40 Mesh were used as the adsorbent in this study.

C. Pressure Swing Adsorption

Double-column PSA apparatus used in this study was built in-house. The schematic diagram of the system is show in Fig. 1. The adsorption columns were made of stainless steel columns with a length of 30 cm and an inner diameter of 5 cm.

At the beginning of the experiment, the evaporator was filled with an ethanol solution with 90-92 %wt of ethanol. The heater was turned on and the cycle time of the operation was set by timer controller. The optimal cycle time for the apparatus used in this study was found to be 4 min for adsorption and 1 min for desorption (Adsorption /Desorption: 4/1). When the pressure in the evaporator reached up to the desired adsorption pressure, valve GV-1 was opened. The ethanol vapor was passed through the top of column-1 where water adsorption was firstly taken place.

III. RESULTS AND DISCUSSION

Three operating variables of ethanol dehydration by PSA process were investigated in this study, i.e. adsorption temperature (T), adsorption pressure (P), and feed flow rate. The latter was controlled by adjusting the percent opening (v) of valve GV-1 at the evaporator. Values of the variables in each experiment are shown in Table I. The process outputs of interest were ethanol concentration in the product and ethanol production expressed in grams ethanol per gram adsorbent (g_{EtOH}/g_{ads}).

TABLE I
 OPERATING VARIABLES OF PSA PROCESS

Run	T(°C)	P (bar)	v (% valve opening)
1	110	1	50
2	120	1	50
3	130	1	50
4	120	2	25
5	120	2	50
6	120	2	75

A. Effect of Adsorption Temperature

The effect of the adsorption temperature on capability of cassava-based adsorbent to remove water from ethanol was investigated. The results are shown in Fig. 2. It can be seen that the concentration of ethanol in the product at adsorption

temperature of 120 and 130°C were significantly higher than at 110°C. This could be due to some degree of vapor condensation when the temperature was not sufficiently high because the used adsorbent in experiment with adsorption temperature of 110°C appeared to be quite wet.

The used adsorbent was found to be partially burned in experiment with adsorption temperature of 130°C despite the high ethanol concentration obtained in the product. As a result, the optimum temperature was chosen to be at 120°C in this study.

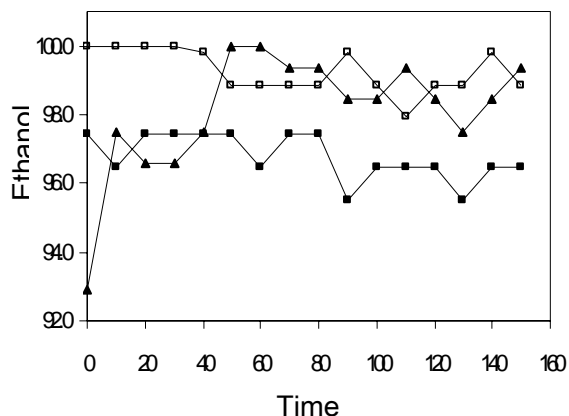

Fig. 2 Effect of adsorption temperature on concentration of ethanol product (%wt): ■ 110 °C; □ 120 °C; ▲ 130 °C

B. Effect of Adsorption Pressure

The effect of adsorption pressure was studied at 1 and 2 bar (2 and 3 bar absolute), and the ethanol concentration obtained from the process are shown in Fig. 3. It can be observed that the concentration of ethanol product was increased with adsorption pressure. The optimum adsorption pressure for the apparatus used in this study was therefore chosen to be at 2 bar.

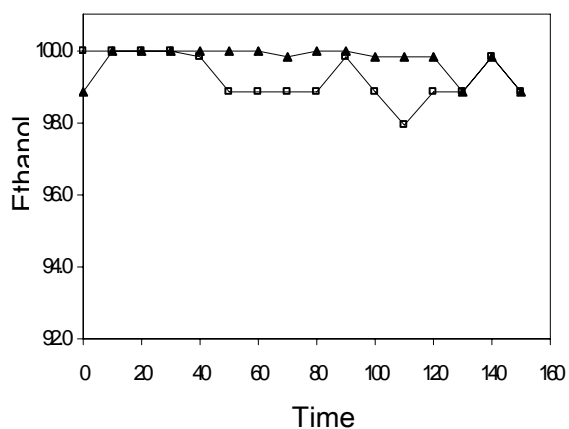

Fig. 3 Effect of adsorption pressure on concentration of ethanol product (%wt): □ 1 bar; ▲ 2 bar.

C. Effect of Feed Flow Rate

Effect of feed flow rate on ethanol concentration in the product is shown in Fig. 4, which indicates that decreasing feed flow rate by decreasing percent opening of valve GV-1 at the evaporator could improve the concentration of ethanol in the product. This was likely due to longer contact time between the vapor and the adsorbent at low feed flow rate.

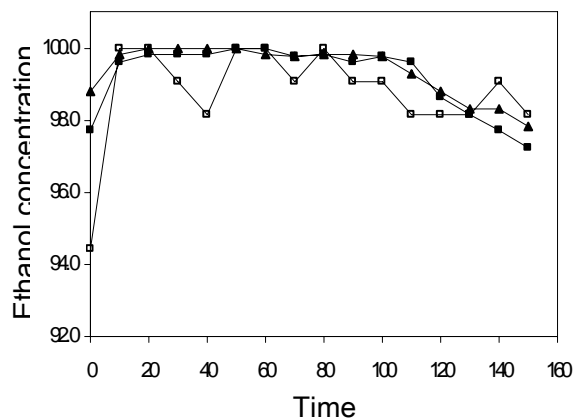

Fig. 4 Effect of feed flow rate on concentration of ethanol product (%wt): ■ 25 %valve opened; ▲ 50 %; □ 75 %valve opened

Ethanol production, g_{EtOH}/g_{ads} , obtained from experiments with different values of operating variables are shown in Table 2. As seen, the ethanol production was found to be highest at percent valve opening of 25%. This value was thus selected as the optimum point for feed flow rate controlling in this study.

TABLE II
 ETHANOL PRODUCTION FROM PSA WITH CASSAVA ADSORBENT

T (°C)	P (bar)	v (%valve opening)	g_{EtOH}/g_{ads} (99.5%wt)
110	1	50	-
120	1	50	0.767
130	1	50	0.228
120	2	50	1.366
120	2	25	1.480
120	2	75	0.706

IV. CONCLUSIONS

Ethanol dehydration in PSA process using cassava adsorbent was tested in this study. Effect of three operating variables i.e. adsorption temperature, adsorption pressure and feed flow rate, on ethanol concentration in the product and ethanol production from the system were investigated in order to obtain the optimum operating conditions of the apparatus. Results from various experiments showed that increasing adsorption pressure and decreasing of the feed flow rate led to increased concentration of ethanol in the product. The

optimum conditions were found to be at 120°C for adsorption temperature, 2 bar for adsorption pressure, and 25% valve opening at the evaporator for feed flow rate controlling. This study elucidates that cassava pulp could be a raw material for preparation of adsorbent with target use of water adsorption. In conclusion, water adsorption with cellulose-based adsorbent could be an economical technique to produce anhydrous ethanol in country with large area of cassava plantation like Thailand.

ACKNOWLEDGMENT

The authors are grateful to Princess Maha Chakri Sirindhorn's Innovation and Invention Research Fund, Suranaree University of Technology, for financial support of this work.

REFERENCES

- [1] M. Ladisch and K. Dyck, "Dehydration of Ethanol: New Approach Gives Positive Energy Balance," *Science*, vol. 205, pp. 898-900, 1979.
- [2] M. Ladisch, M. Voloch, J. Hong, P. Blenkowski and G. Tsao, "Commeal Adsorber for Dehydrating Ethanol Vapors," *I&EC Proc. Des. Develop.*, vol. 23, pp. 437-443, 1984.
- [3] H. Chang, X. Yuan, H. Tian and A. Zeng, "Experiment and Prediction of Breakthrough Curves for Packed Bed Adsorption of Water Vapor on Commeal," *Chem. Eng. Process.*, vol. 45, pp. 747-754, 2006.
- [4] J. Hong, M. Voloch, M. Ladisch and G. Tsao, "Adsorption of Ethanol-Water Mixtures by Biomass Materials," *Biotech. Bioeng.*, vol. 24, pp. 725-730, 1982.
- [5] P. Bienkowski, A. Barthé, M. Voloch, R. Neuman and M. Ladisch, "Breakthrough Behavior of 17.5 mol% Water in Methanol, Ethanol, Isopropanol, and t-Butanol Vapors Passed over Corn Grits," *Biotech. Bioeng.*, vol. 28, pp. 960-964, 1986.
- [6] L. Anderson, M. Gulati, P. Westgate, E. Kvam, K. Bowman and M. Ladisch, "Synthesis and Optimization of a New Starch-Based Adsorbent for Dehumidification of Air in a Pressure-Swing Dryer," *Ind. Eng. Chem. Res.*, vol. 35, pp. 1180-1187, 1996.
- [7] M. Ladisch, "Biobased Adsorbents for Drying of Gases," *Enzyme Microb. Tech.*, vol. 20, pp. 162-164, (1997).
- [8] T. Benson and C. George, "Cellulose Based Adsorbent Materials for the Dehydration of Ethanol Using Thermal Swing Adsorption," *Adsorption*, vol. 11, pp. 697-701, 2005.
- [9] G. Vareli, P. Demertzi and K. Akrida-Demertzi, "Effect of Regeneration Thermal Treatment of Cellulosic and Starchy Materials on Their Capacity to Separate Water and Ethanol," *J. Cereal Sci.*, vol. 31, pp. 147-154, 2000.
- [10] X. Han, X. Ma, J. Liu and H. Li, "Adsorption Characterisation of Water and Ethanol on Wheat Starch and Wheat Gluten Using inverse Gas Chromatography," *Carbohydrate. Polym.*, vol. 78, pp. 533-537, 2009.
- [11] A. Al-Asheh, F. Banat and N. Al-Lagtah, "Separation of Ethanol-Water Mixtures Using Molecular Sieves and Biobased Adsorbents," *Trans IChemE, Part A, Chem. Eng. Res. Des.*, vol. 82(A7), pp. 855-864, 2004.
- [12] K. Beery, and M. Ladisch, "Chemistry and Properties of Starch Based Desiccants," *Enzyme Microb. Tech.*, vol. 28, pp. 573-581, 2001.
- [13] K. Beery, and M. Ladisch, "Adsorption of Water from Liquid-Phase Ethanol-Water Mixtures at Room Temperature Using Starch-Based Adsorbents," *Ind. Eng. Chem. Res.*, vol. 40, pp. 2112-2115, 2001.
- [14] Chontira Boonfung, Panarat Rattanaphanee, Cassva-based adsorbent for ethanol dehydration, *J. KMUTNB*, vol. 20, No. 2, pp. 196-202, 2010.