

Power Control in a Doubly Fed Induction Machine

A. Ourici

Abstract—This paper proposes a direct power control for doubly-fed induction machine for variable speed wind power generation. It provides decoupled regulation of the primary side active and reactive power and it is suitable for both electric energy generation and drive applications. In order to control the power flowing between the stator of the DFIG and the network, a decoupled control of active and reactive power is synthesized using PI controllers. The obtained simulation results show the feasibility and the effectiveness of the suggested method

Keywords—Doubly fed induction machine , decoupled power control , vector control ,active and reactive power, PWM inverter

I. INTRODUCTION

THE wind energy systems using a doubly-fed induction generator (DFIG) have some advantages due to variable speed operation and four quadrant active and reactive power capabilities compared with fixed speed induction. Some investigations by using predictive functional controller [1] and internal mode controller [2], [3] have satisfactory power response when compared with the power response of PI but it is hardly to implement one due to the predictive functional controller and internal mode controller formulation. Another possibility to doubly-fed power control. can be made by using fuzzy logic [4], [5]. These strategies have satisfactory power response although it involves relatively complex transformation of voltages, currents and control outputs among the stationary, the rotor and the synchronous reference frames. The direct power control was applied to the DFIG power control and it has been presented in [6], [7], [8]. This scheme calculates the required rotor controlling voltage directly based on the estimated stator flux, active and reactive power and their errors. In [6] the principles and the implementation of DPC is made with hysteresis controllers and variable switching frequency. In [7], [8] the principles of this method are described in detail and simulations results have been presented with variable and constant switching frequency respectively. Moreover, the conventional DPC complicates the AC filter design because of its variable switching frequency. An alternative to direct power control is the power error vector control [9]. This strategy is less complex and obtains similar results to direct power control. To improve the power response, to eliminate the torque ripple and to protection of rotor-side converter under grid voltage sags a proportional control with anti-jamming control was proposed in [10]. This control has satisfactory power response and eliminate the rotor current overshoot in voltage sags when the

loop of torque control is applied, although power and rotor currents results were shown only in fixed speed operation. We present in this paper a direct power control , it results a good decoupling control between active and reactive power, it achieves high accuracy and fast dynamic power response.

II. DESCRIPTION AND MODELING OF DFIM

The proposed system is shown on figure 1, it is constituted by two pulse width modulation inverters supplying separately the stator and the rotor of the machine [11]

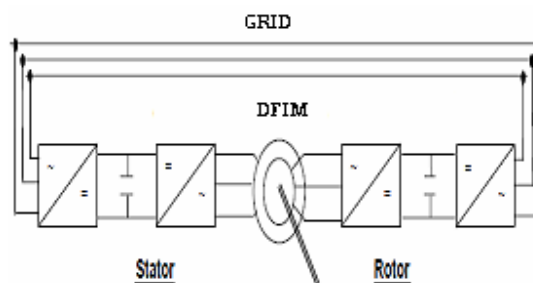

Fig .1 DFIM supplied by two PWM inverters

We choose three levels PWM for both stator and rotor inverters, it is constitute of three arms, every one has four switches formed by a transistor and a diode as shown in figure 2

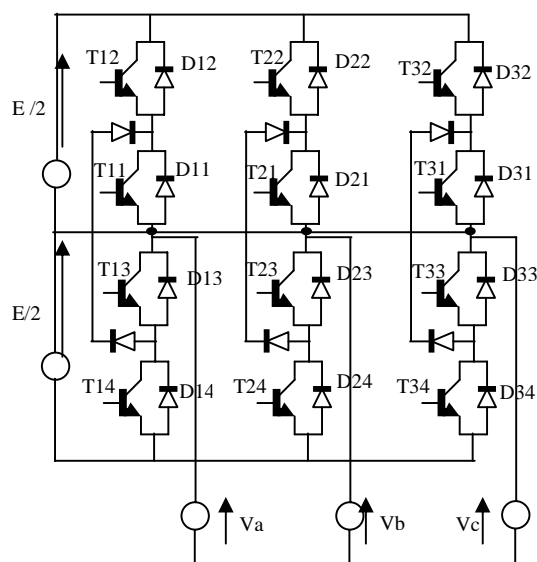

Fig .2 General diagram of a three level PWM inverter

The simple voltages are obtained starting from the following conditions:

A. Ourici is now with electrical engineering institute of Badji Mokhtar University of annaba Algeria; a_ourici@hotmail.com

If ($V_{ref} = V_p$) and ($V_{ref} > 0$)

$$\Rightarrow V_K = +E/2$$

If ($V_{ref} = V_p$) and ($V_{ref} < 0$)

$$\Rightarrow V_K = -E/2$$

If $V_{ref} = V_p \Rightarrow V_K = 0$

With

V_{ref} : reference voltage standard;

V_p : carrying;

V_K : potential of the node K.

$$\begin{cases} \psi_{ds} = L_s I_{ds} = M I_{dr} \\ \psi_{qs} = L_s I_{qs} + M I_{qr} \\ \psi_{dr} = L_r I_{dr} + M I_{ds} \\ \psi_{qr} = L_r I_{qr} + M I_{qs} \end{cases} \quad (3)$$

Mechanic equation is given by:

$$C_{em} = Cr + J \frac{d\Omega}{dt} + f\Omega \quad (4)$$

Open Science Index, Electrical and Computer Engineering Vol:5, No:5, 2011 publications.waset.org/11875.pdf

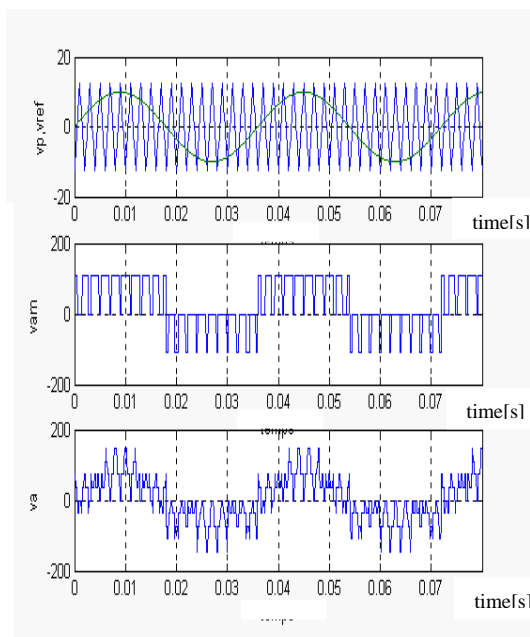

Fig .3 Carrying voltage, simple voltage and phase voltage

Stator and rotor voltages of the machine after Park transformation are given by [12]:

$$\begin{cases} V_{ds} = R_s I_{ds} + \frac{d}{dt} \psi_{ds} - \frac{d\theta_s}{dt} \psi_{qs} \\ V_{qs} = R_s I_{qs} + \frac{d}{dt} \psi_{qs} + \frac{d\theta_s}{dt} \psi_{ds} \end{cases} \quad (1)$$

$$\begin{cases} V_{dr} = R_r I_{dr} + \frac{d}{dt} \psi_{dr} - \frac{d\theta_r}{dt} \psi_{qr} \\ V_{qr} = R_r I_{qr} + \frac{d}{dt} \psi_{qr} + \frac{d\theta_r}{dt} \psi_{dr} \end{cases} \quad (2)$$

Stator and rotor fluxes are given by:

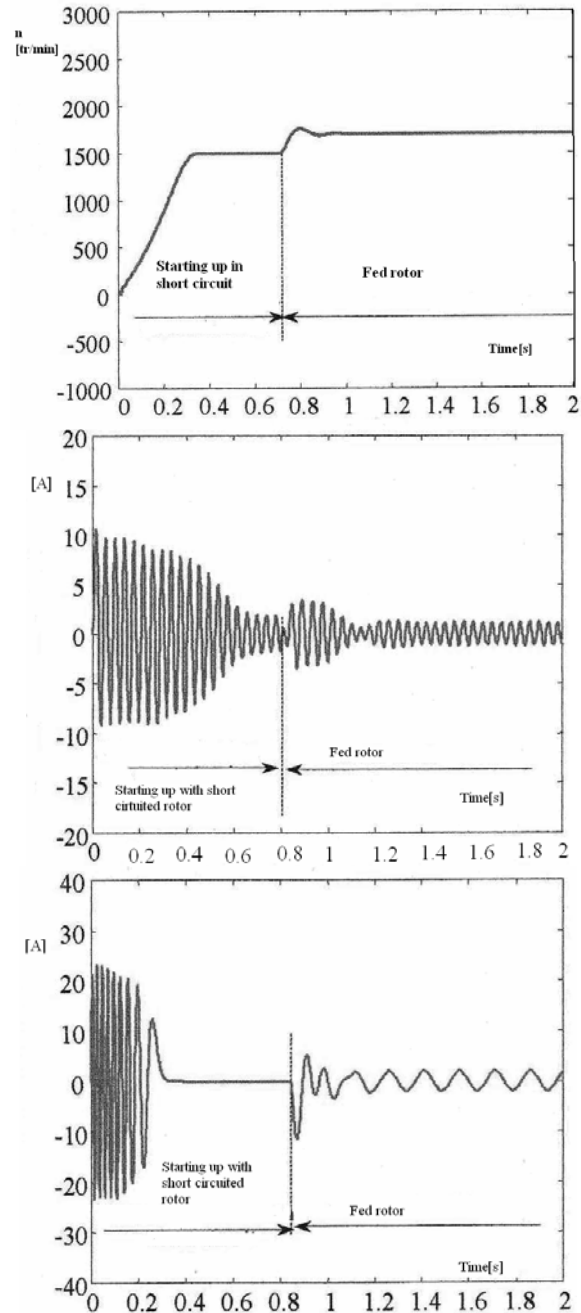

Fig .4 Speed, stator current and rotor current during starting up of the machine

III. CONTROL STRATEGIES

By orienting rotor flux towards d-axis, and stator flux towards q-axis. Conventionally, the d-axis remains reserved to magnetizing axis and q-axis to torque axis, we obtain

$$\begin{aligned} \psi_{sq} &= \psi_s, \\ \psi_{rd} &= \psi_r, \\ \psi_{sd} &= \psi_{rq} = 0. \end{aligned}$$

Then the developed torque can be written like this

$$C_{em} = Dc\psi_s\psi_r, Dc = pM/\sigma L_s L_r$$

Vectoriel diagrams before and after flux orientation are shown as follows [13]

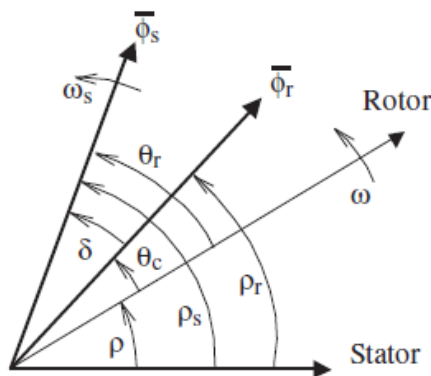

Fig. 5 DFIM flux relative armature position

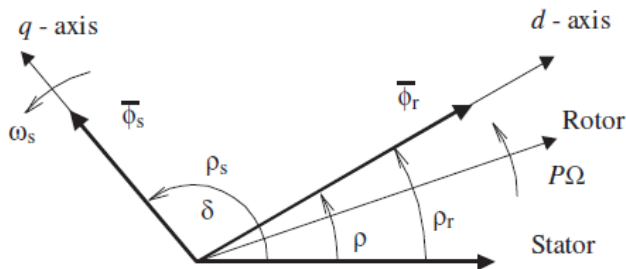

Fig. 6 DFIM vectorial diagram after orientation

The stator active and reactive powers can be written as:

$$\begin{aligned} P &= V_{ds} \cdot I_{ds} + V_{qs} \cdot I_{qs} \\ Q &= V_{qs} \cdot I_{ds} - V_{ds} \cdot I_{qs} \end{aligned}$$

After all calculations we can draw up this plan:

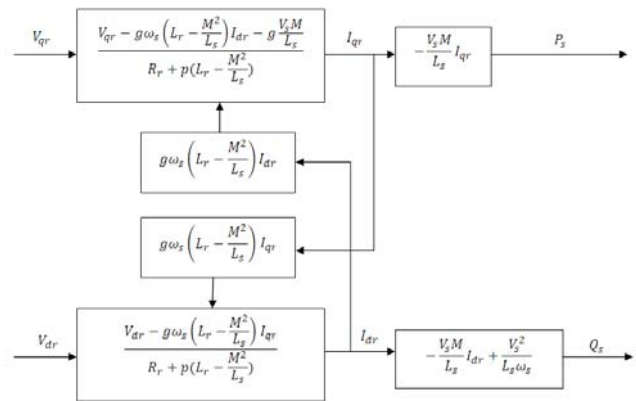

Fig. 7 Block diagram of the DFIM

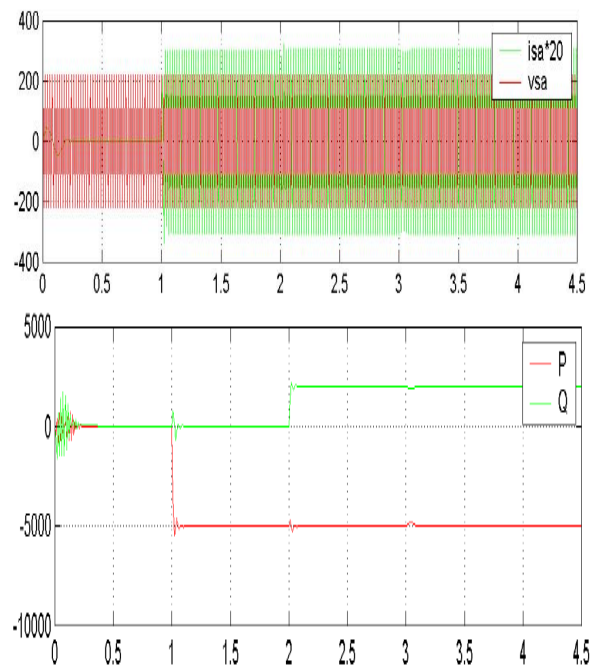

Fig. 8 Stator voltage and current, active and reactive power

IV. RESULTS ANALYSIS

Figure 3 shows the carrying voltage, simple voltage and phase voltage of the three levels inverters used. Figure 4 presents speed, stator current and rotor current in the starting up of the machine, until 0.8s the machine starts with rotor in short circuit, after the rotor is fed by the inverter. In figure 8 we can see stator voltage and current, and active and reactive power, at time equal to 1s, we forced the active power to -5Kw, the reactive power did not react, also we give a level of 2 KVA to the reactive power and the active one did not react, we can conclude that we effectively made a decoupling between both powers. It can be said that this strategy in addition of its simplicity, shows good results.

V. CONCLUSION

We present in this paper a simulation of a doubly fed induction machine fed with two pulse width modulation inverters, based on d-q modeling. Access to the stator and rotor windings is one of the advantages of the wound rotor induction machine compared to the conventional squirrel-cage machine, consequently the doubly fed induction machine offer the several possible combinations for its control. A double flux orientation was presented, Since the fluxes are used like control variables, the machine fluxes must be maintained at acceptable level especially during the transient regimes. In addition of that, we made a success to decouple the active and the reactive power. This control development has enabled us to highlight several interesting aspects for further study on the whole power wind production. It is obvious that direct method is easier to implement than the indirect one.

REFERENCES

- [1] Z. Xin-fang, X. Da-ping, and L. Yi-bing, "Predictive functional control of a doubly fed induction generator for variable speed wind turbines," IEEE World Congress on Intelligent Control and Automation, June 2004.
- [2] J. Morren and M. Sjoerd W. H. de Haan, "Ridethrough of wind turbines with doubly-fed induction generator during a voltage dip," IEEE Transactions on Energy Conversion, vol. 20, no. 2, pp. 435–441, June 2005.
- [3] J. Guo, X. Cai, and Y. Gong, "Decoupled control of active and reactive power for a grid-connected doubly-fed induction generator," Third International Conference on Electric Utility Deregulation and Restructuring and Power Technologies. DRPT 2008., pp. 2620 – 2625, April 2008.
- [4] J. P. A. V. and Marcus Vinicius Alves Nunes, U. H. Bezerra, and A. C. do Nascimento, "Controladores fuzzy aplicados ao conversor de geradores de indução duplamente excitados em sistemas eólicos integrados a sistemas de potência," Revista Controle & Automação, vol. 18, no. 1, pp. 115–126, Jan., Feb., March 2007.
- [5] X. Yao, Y. Jing, and Z. Xing, "Direct torque control of a doubly-fed wind generator based on grey-fuzzy logic," International Conference on Mechatronics and Automation. ICMA 2007., pp. 3587 – 3592, August 2007.
- [6] R. Datta and V. T. Ranganathan, "Direct power control of grid-connected wound rotor induction machine without rotor position sensors," IEEE Transactions on Power Electronics, vol. 16, no. 3, pp. 390 – 399, May 2001.
- [7] L. Xu and P. Cartwright, "Direct active and reactive power control of dfig for wind energy generation," IEEE Trans. on Energy Conversion, vol. 21, no. 3, pp. 750–758, September 2006.
- [8] D. Zhi and L. Xu, "Direct power control of dfig with constant switching frequency and improved transient performance," IEEE Trans. on Energy Conversion, vol. 22, no. 1, pp. 110–118, March 2007.
- [9] I. de Alegria, J. Andreu, P. Ibanez, J. L. Villate, and I. Gabiola, "Novel power error vector control for wind turbine with doubly fed induction generator," Industrial Electronics Society, 2004. IECON 2004. 30th Annual Conference of IEEE, vol. 2, pp. 1218–1223, November 2004.
- [10] G. Xiao-Ming, S. Dan, H. Ben-Teng, and H. Ling-Ling, "Direct power control for wind-turbine driven doubly-fed induction generator with constant switch frequency," International Conference on Electrical Machines and Systems, pp. 253–258, October 2007.
- [11] F. Bonnet, P. E. Vidal and M. Pietrzak-David, "Direct control of doubly fed induction machine", Bulletin of the polish academy of sciences, Technical sciences, Vol 54, N°3, 2006
- [12] Paul Etienne VIDAL, "Commande non linéaire d'une machine asynchrone à double alimentation", Thesis of doctorate, Toulouse France, december 2004.
- [13] S. Drid, M. Tadjine, M.S. Nait Said, "Nonlinear feedback control and torque optimisation of a doubly fed induction motor", Journal of electrical engineering, vol 56, N° 3-4, pp 57 63, 2005