

An Energy Integration Approach on UHDE Ammonia Process

Alnouss M. Ahmed, and Al-Nuaimi A. Ibrahim

Abstract—In this paper, the energy performance of a selected UHDE Ammonia plant is optimized by conducting heat integration through waste heat recovery and the synthesis of a heat exchange network (HEN). Minimum hot and cold utility requirements were estimated through IChemE spreadsheet. Supporting simulation was carried out using HYSYS software. The results showed that there is no need for heating utility while the required cold utility was found to be around 268,714 kW. Hence a threshold pinch case was faced. Then, the hot and cold streams were matched appropriately. Also, waste heat recovered resulted with savings in HP and LP steams of approximately 51.0% and 99.6%, respectively. An economic analysis on proposed HEN showed very attractive overall payback period not exceeding 3 years. In general, a net saving approaching 35% was achieved in implementing heat optimization of current studied UHDE Ammonia process.

Keywords—Ammonia, Energy Optimization, Heat Exchange Network and Techno-Economic Analysis.

I. INTRODUCTION

PROCESS integration is divided into two principal types: mass integration, and energy integration [1]. The urge of process optimization is to minimize the amounts of raw materials used, discharged waste, and utilities requirements [1]. Thus, recycling valuable waste material and utilizing waste energy generated by different industrial activities. As a result, substantial reduction in capital and operating costs while appreciable increase in profit. Heat integration involves targeting minimum heating and cooling duties required to operate a plant, employing best heat exchangers network configuration that can achieve the aforementioned targets, and convert waste energy into valuable energy to serve various applications within chemical plant [1]. Mass integration focuses on achieving a set of mass objectives: reducing waste material, maximizing product's yield, and decreasing required fresh material [1]. Heat is one of the significant sectors of energy integration, where it studies the feasibility of transferred heat from hot side to the cold side of the process while respecting all relevant thermodynamics laws [1].

The basic principles of process integration rely on two fundamentals [2]:

1. Considering the big picture of the system ahead of detailed design, by looking at the entire manufacturing process as an integrated system.

AlNouss M. Ahmed is with Qatar University, Doha, Qatar (corresponding author to provide phone: 00974-55533690; e-mail: a.alnouss@qu.edu.qa).

Al-Nuaimi A. Ibrahim with Texas A&M University at Qatar, Doha, Qatar; (e-mail: Ibrahim.al-nuaimi@qatar.tamu.edu).

2. Applying process-engineering principles as key process steps to establish prior targets for the use of materials and energy. Taking into consideration generated emissions and wastes from chemical plant.

Process Heat integration and waste heat recovery analyses are two significant tasks in optimizing performance of chemical plant, they study all possible interactions between related units simultaneously in order to produce what is called an "energy integrated system". This paper is focused on heat energy integration where the selected UHDE Ammonia plant will be optimized to estimate minimum energy requirements, implement most economical heat exchange network (HEN), and utilize valuable enthalpy content of discharged flue gases through waste heat recovery principles.

Ammonia is a fast growing petrochemical industry in Qatar, new mega production trains are being established sequentially to meet the continuous worldwide demand of high quality fertilizers. QAFECO (Qatar Fertilizers Company) has started up train 5 few months ago and train 6 is on its way to be started up by the end of 3rd quarter of current year, boosting net production of liquid Ammonia from 2.2 MMT to 3.8 MMT annually [3], and putting Qatar on the top of the list as the largest Ammonia producer in the world. Moreover, Ammonia process is an energy intensive process where huge energy demand is needed to produce synthesis gas essential for main synthesis reaction at reforming section, and MDEA regeneration at CO₂ removal section to recover the valuable absorbent solution. These two factors together make both heat integration and waste heat recovery analyses promising optimizations for Ammonia process.

Ammonia process under study runs according to UHDE technology and has production capacity of 2,000 MTPD (metric tons per day) of fine quality of liquid Ammonia.

II. PAPER SIGNIFICANCE

Ammonia is a fast growing petrochemical industry in Qatar, new mega production trains are being established annually to meet the continuous worldwide demand. Moreover, Ammonia process is an energy intensive process where huge energy demand is needed to produce synthesis gas essential for main synthesis reaction at reforming section, and MDEA regeneration at CO₂ removal section to recover the valuable absorbent solution. These two factors together make both heat integration and waste heat recovery analyses promising optimizations for Ammonia process. Considered UHDE process has capacity of 2,000 MTPD (metric tons per day) of liquid Ammonia and run according to real industrial data gathered from local representative, QAFECO (Qatar Fertilizers

Company). Fig. 1 illustrates a typical PFD (Process Flow Diagram) for UHDE Ammonia process.

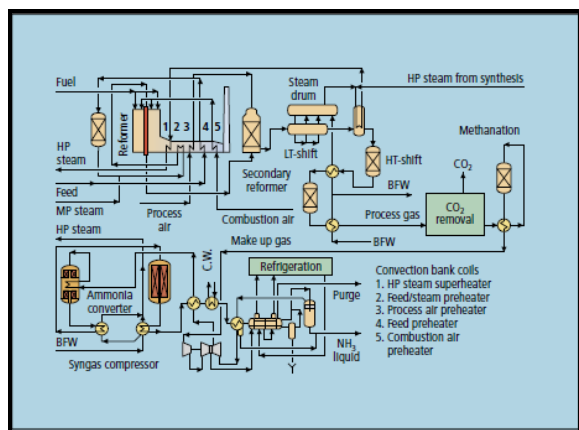

Fig. 1 Typical PFD of UHDE Ammonia process [4]

A. Objectives

This aim of this paper is to accomplish the following goals:

1. Heat integration analysis between hot and cold streams denoted by pinch analysis (graphical) and cascading (algebraic) using ICheme spreadsheet.
2. Waste heat recovery analysis to utilize the valuable enthalpy content of discharged flue gases into heat integration applications.
3. Best heat exchange network (HEN) that meets the targets and associated with least number of shell and tube heat exchangers.
4. Economic analysis of selected HEN to verify feasibility of construction.
5. Optimum distribution of external utilities aided by grand composite curve (GCC).

III. UHDE AMMONIA PROCESS

UHDE Ammonia process as petrochemical process passes through three major steps: synthesis gas production, gas purification, and Ammonia synthesis, in which it is comprised of five main sections: reforming, CO conversion, CO₂ removal, methanation, and Ammonia synthesis sections [4]. Fig. 2 shows an overall block diagram of UHDE Ammonia process including principal reactions taking place through.

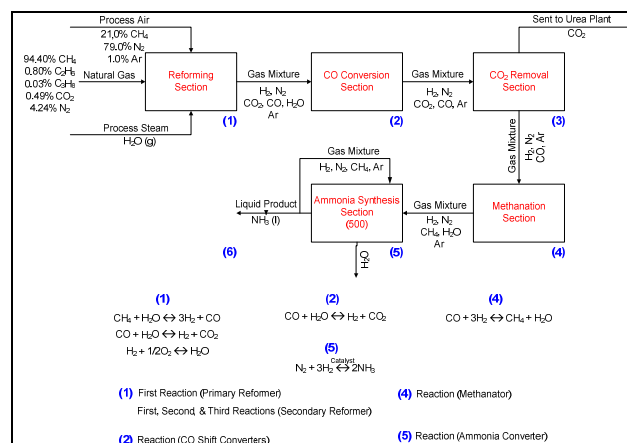

Fig. 2 Overall block diagram of UHDE Ammonia process

IV. STUDY APPROACH

The following subsections give an insight about the steps followed in performing process optimization on considered Ammonia process divided into two principal tasks; process heat integration tools using pinch technology and problem table method (cascading method) and waste heat recovery analysis. This section started by introducing some important terminology on the science of process optimization, such as minimum temperature difference.

A. Minimum Temperature Difference (ΔT_{min})

The second law of thermodynamics states that 'natural heat transfer always takes place from the hot reservoir to the cold reservoir unless external energy (force) is applied on the system' [5]. Minimum temperature difference ' ΔT_{min} ' is a significant parameter in process integration that sets specific temperature range to be satisfied along the temperature profile of heat exchanger. It determines relative locations of hot and cold streams on T-H diagram and quantifies amount of heat recovery in integrated process as going to be explained further in pinch technology section [1].

Minimum temperature difference is one of the frequently faced internal constraints in process integration because it is a predefined parameter by designer for all heat exchangers within the chemical plant. Specific temperature difference value set by designer should be respected all along the temperature profiles between the two edges of the heat exchanger, or otherwise violation to second law of thermodynamics could take place due to lack of temperature driving force as overlapping will take place between hot and cold streams [6].

Minimum temperature difference is basically a "trade-off" parameter between operating cost and capital cost, by evaluating process performance and process economics aspects at the same time. A lot of studies and calibrations have been done before by chemical engineers to find optimum value for employing through all chemical processes. Studies showed that this parameter has a large range of temperatures ranging between (3 – 30) °C. However, optimum approach temperature difference for shell and tube heat exchangers was realized to

be 10 °C [7]. Fig. 3 illustrates the relation between minimum temperature difference and operating/fixed cost.

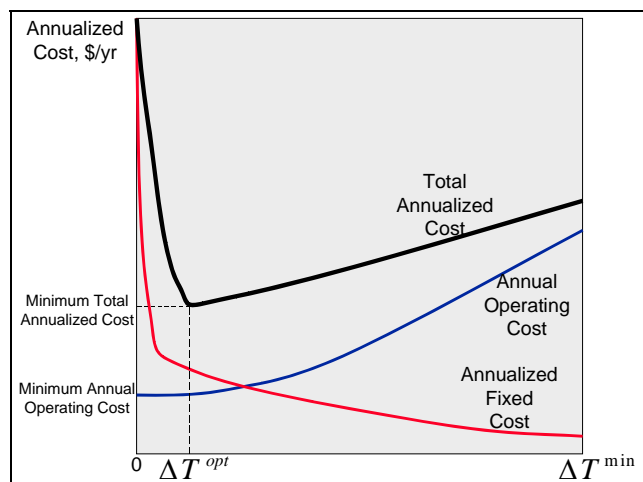

Fig. 3 The influence of minimum temperature difference on process economics [1]

The way of obeying minimum temperature difference depends on heat exchangers configurations; countercurrent has different approach than co-current heat exchangers [7]. For countercurrent, hot process inlet stream is compared with cold utility outlet, and hot process outlet stream is compared with cold inlet utility stream. For co-current, hot process inlet stream is compared with cold inlet utility stream, and hot outlet process stream is compared with cold outlet utility stream [7]. Fig. 4 illustrates the difference in calculating minimum temperature difference of specific shell and tube heat exchanger for countercurrent and co-current heat exchangers configurations.

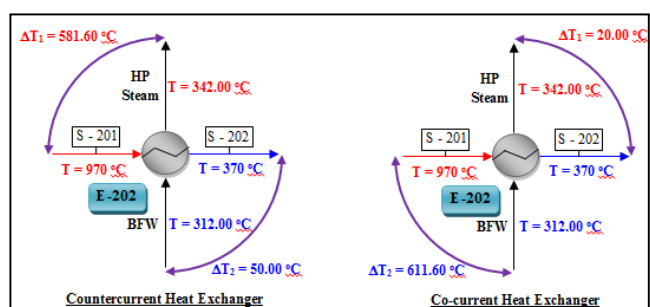

Fig. 4 Difference in calculating minimum temperature difference for co-current and countercurrent heat exchangers

B. Pinch Technology

Pinch technology is one of the widely used analysis methods for heat integration. It is illustrated by a simple drawing of temperature versus exchanged heat load indicated shortly as T-H diagram. An important terminology in describing borders of process stream temperatures is the ‘supply temperature’, which is the starting temperature of the stream, and ‘target temperature’, which is the desired temperature by the stream [1]. This method starts by converting all supply/target actual temperatures into new temperatures accounting for the specified minimum temperature difference called ‘interval

temperatures” [1]. These interval temperatures can be calculated using the following mathematical relations [7]:

$$\text{Hot Stream: } T_{\text{int}} = T_{\text{act}} - \frac{\Delta T_{\text{min}}}{2} \quad (1)$$

$$\text{Cold Stream: } T_{\text{int}} = T_{\text{act}} + \frac{\Delta T_{\text{min}}}{2} \quad (2)$$

Where,

T_{int} : Interval temperature (°C).

T_{act} : Supply of target temperature of hot or cold stream (°C).

ΔT_{min} : Minimum temperature difference (°C).

As the interval temperatures are ranked based on descending order, the number of temperature intervals is determined, and in turn sharing regions between process streams are specified. All parts of hot streams occupying same temperature interval are combined together and a new line is drawn on T-H diagram which is called ‘hot composite curve’ [1]. Also, all sections of cold streams existing at same temperature interval are combined together and a new line is drawn on T-H diagram which is called ‘cold composite curve’ [1]. Fig. 5 expresses the methodology behind constructing hot and cold composite curves.

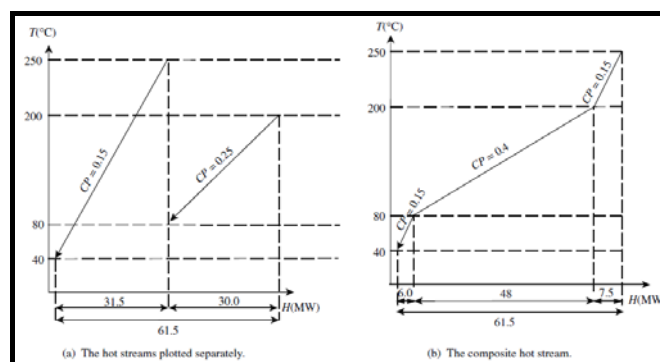

Fig. 5 Methodology of developing hot and cold composite curves [7]

Finally, the two composite curves are drawn together on T-H diagram with certain spacing controlled by minimum temperature difference. Pinch point of the process to be optimized is located at the least temperature difference between the two curves, after shifting one or both curves horizontally to meet each other as long as thermal feasibility is assured. This graph is referred to as ‘heat exchange pinch diagram’ [1]. Fig. 6 illustrates the location of pinch point as the two composite curves brought close to each other.

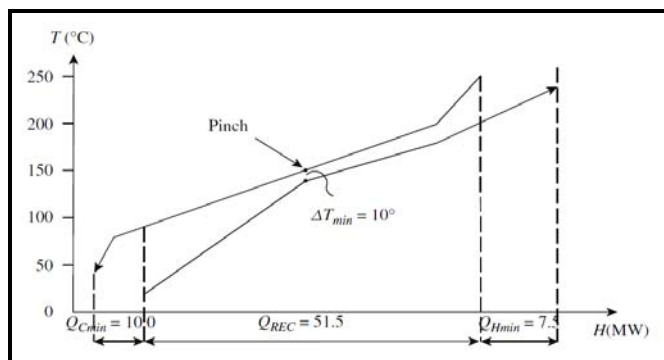

Fig. 6 Location of pinch point on T-H diagram [7]

Three significant information can be extracted from pinched diagram; area of recovery which is located on the empty space between hot and cold composite curves at overlapping region, minimum heating utilities which is the range of heat flow on the x-axis between the tip ends of cold and hot composite curves toward the right hand side, and minimum cooling utilities which is the range of heat flow on the x-axis between the tip ends of cold and hot composite curves toward the left hand side [1]. These three parameters are optimized by manipulating the value of minimum temperature difference; decreasing minimum temperature difference will decrease region of overlapping between hot & cold composite curves in the meantime will reduce minimum heating and cooling requirements, which in turn will increase capital cost since larger area of heat transfer need to be employed through heat exchanger design [7]. Increasing minimum temperature difference will increase area of recovery between hot & cold composite curves in the meantime will increase minimum heating and cooling requirements, which in turn will increase operating cost since increased pumping requirement is required as higher amount of utilities are supplied [7]. This proves what emphasized previously through Fig. 6 that minimum temperature difference is like a trade-off parameter between process optimization and related process economics

It is important to mention that at the pinch point heat cannot be transferred between hot and the cold streams. Below the pinch point, cold utilities are used only and above the pinch point hot utilities are used only. Finally, the hot curve must always be above the cold curve for heat transfer and recovery, or otherwise external utilities are required to satisfy the uncovered regions of the two curves [1].

C. Problem Table Method (Cascading Method)

This method is the second widely used method in performing heat integration on target process. It is used more often because it is more convenient than the graphical method. The objective of problem table method is to identify minimum heating and cooling requirements required for chemical process, determine thermal pinch point, possible areas of heat integration in chemical plant at which hot and cold streams can exchange heat, and optimize the utilization of available external duties to meet energy needs with least cost. Cascading method is implemented based on the following summarized steps [8]:

1. Converting actual process stream temperatures into interval temperatures.
2. Eliminating repeated interval temperatures.
3. Ranking resulted interval temperatures in descending order.
4. Calculating temperature differences between each interval.
5. Calculating associated heat flows by each process stream.
6. Heat surplus for the positive values are cascaded.
7. The negative cascaded values are thermodynamically not feasible, so heat must be added to eliminate any negative cascaded value, which is identified as the minimum heating requirement.
8. Heat removed at the bottom of the cascade is the minimum cooling requirement.

D. Heat Exchange Network Design by Grid Representation

It is an effective way to determine the minimum hot and cold utilities needed in a chemical plant. It is a very helpful tool in evaluating possible streams matching by drawing all process streams under consideration horizontally and dividing them at the pinch point based on two main regions: above the pinch point, and below the pinch point [1]. For maximum energy recovery, no cooling must be used above the pinch point. Therefore, hot streams must be matched with cold streams such that all hot streams load is consumed and what is left from the cold streams load is satisfied with external heating utilities. Every hot stream must be matched with a cold stream immediately above the pinch point otherwise it will not reach the pinch temperature [1]. This introduces an important terminology in process heat integration called the “network design above the pinch”. For hot and cold streams which are immediately above the pinch point (passing through pinch point), the following thermodynamic conditions should apply to have matching between hot and cold streams section occupying same temperature interval [1]:

$$F_u C_{p,u} \leq f_v c_{p,v} \quad (3)$$

$$N_{ha} \leq N_{ca} \quad (4)$$

where,

$F_u C_{p,u}$: Mass specific heat of hot stream u (J/K).

$f_v c_{p,v}$: Mass specific heat of cold stream v (J/K).

N_{ha} : Number of hot streams adjacent to the pinch.

N_{ca} : Number of cold streams adjacent to the pinch.

For maximum energy recovery, no heating utility must be used below the pinch point. So hot streams must be matched with cold streams such that the entire cold streams load is satisfied and what is left from the hot streams load is satisfied with external cooling utilities. Every cold stream must be matched with a hot stream immediately below the pinch point [1]. This introduces another important terminology in process heat integration called “network design below the pinch”. For hot and cold streams which are below the pinch point (passing through pinch point), the following thermodynamic conditions should apply to have matching between hot and cold streams section occupying same temperature interval [1]:

$$F_u C_{p,u} \geq f_v c_{p,v} \quad (5)$$

$$N_{hb} \geq N_{cb} \quad (6)$$

E. Waste Heat Recovery

Waste heat is a sort of waste energy generated due to industrial activities related to fuel combustion or chemical reactions, and released thereafter to surrounding environment even though it still carries huge content of useful enthalpy that could be utilized for some useful and economic purposes. Quality of produced waste heat is described by its value not its relevant amounts. The strategy of how to recover this heat depends in part on the temperature of the waste heat gases and the economics involved [9].

Large quantities of hot flue gases are generated from boilers, ovens and furnaces. If some of this waste heat could be recovered, a considerable amount of primary fuel could be saved. The energy lost in waste gases cannot be fully recovered. However, much of the heat could be recovered and loss minimized by adapting certain evaluating approaches going to be outlined in the following chapter.

Depending on the type of process, waste heat can be rejected at virtually broad range of temperatures starting from chilled cooling water to high temperature waste gases from industrial furnaces or boilers. Usually higher the temperature, higher the quality and more cost effective is the heat recovery. In any study of waste heat recovery, it is absolutely necessary that there should be some use for the recovered heat. Typical examples of use would be preheating of combustion air, space heating, or pre-heating boiler feed water/process water. With high temperature heat recovery, a cascade system of waste heat recovery may be practiced to ensure that the maximum amount of heat is recovered at the highest potential [9]. Heat recovery benefits can be summarized in the following main points [10]:

1. Reduction in pollution (minimizing environmental impact).
2. Reduction in equipment sizes.
3. Reduction in auxiliary energy consumption.
4. Reduction in capital, operating costs, and process cost.
5. Minimizing water/oil consumption in heat exchangers.

V. RESULTS AND DISCUSSIONS

This section summarizes the relative outcomes of both energy optimization techniques employed in this study.

A. Heat Integration Analysis

After all necessary data are fed to IChemE's spreadsheet, data for the other tabs were generated immediately, in which the following tables and graphs are presented: problem table method (cascading method), hot/cold composite curves, pinched diagram, and grid representation of proposed hot/cold process streams.

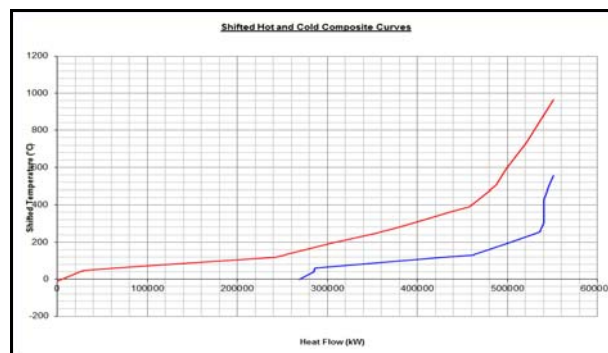

Fig. 7 Pinched diagram for UHDE Ammonia process [11]

Fig. 7 is called the “pinched diagram”. Pinch point cannot be located on the graph because what is encountered in this UHDE Ammonia process, is a special case called “threshold pinch”. It is one of two extreme cases faced in heat integration analysis at which either hot utility or cold utility is not required for the process [8]. In current Ammonia process, hot utility is not needed at all and this is evident by assigned value of zero for minimum required hot utility on the top of feasible cascaded column in problem table. Whereas, large amount of cold utility is needed to reduce temperatures of hot streams to desired process temperatures, and this is evident by assigned value of 268,714.30 kW for minimum required cold utility on the bottom of feasible cascaded column in problem table method. For this kind of cases, pinch point is difficult to locate and it should be either on the right or left tip end of the hot composite curve. In this Ammonia process it is at the right tip end of hot composite curve (hot pinch point only) at 965 °C as noted clearly in problem table method and grid representation.

After all information extracted from IChemE's spreadsheet tabs, optimum heat exchange network for the resulted grid representation on Fig. 8 was initiated to apply feasible matching's between hot and cold streams.

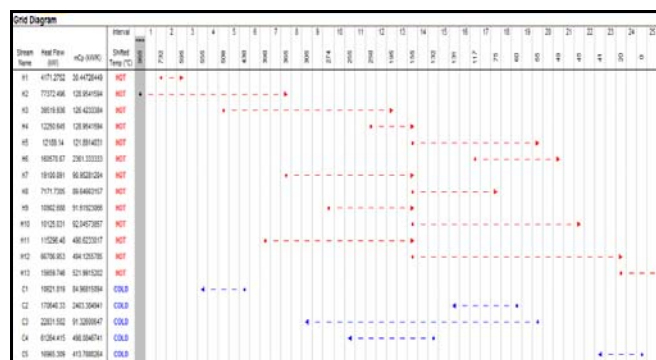

Fig. 8 Grid representation diagram of UHDE Ammonia process [11]

Studying the grid representation of UHDE Ammonia process on Fig. 8, there are no possible matching's between hot and cold streams above the pinch point, since there are no streams existing in that region. Whereas in the case below the pinch point, there are possible matching's between hot and cold streams, since there is an overlapping region as going to be clarified further. The cold stream is occupying a region of shift temperatures ranging between (0 & 555) °C. However,

the hot streams are located on a region of shift temperatures ranging between (965 & -10) °C. This leads to allowable region of matching between six proposed hot process streams (H2, H3, H6, H11, and H12) with the proposed cold process streams (C1, C2, C3, C4, and C5) at region ranging between (0 & 555) °C.

Matching's between the six mentioned proposed hot process streams with the proposed cold process streams below the pinch point, are not restricted to 'FCP condition' stated earlier since all streams under consideration are far away from the pinch point (not adjacent). Lack of 'FCP condition' in the section below the pinch point, made the procedure for finding optimum heat exchange network flexible and raised several options that could be feasible regarding the configuration of grid representation for the process streams within overlapping region. However, AIHA team has decided to study a single feasible matching option. Feasibility of option was verified by having proper temperature profiles free of overlapping spots between the two ends of installed countercurrent heat exchangers, in the meantime obeying minimum temperature difference proposed earlier which was 10 °C, by gathering temperature difference between hot inlet/cold outlet and hot outlet/cold inlet equal to or greater than 10 °C.

In order to understand the feasibility of the proposed heat integration representation, a payback period analysis was done on the heat exchangers. The main resulted parameters showed that the proposed heat integration study is promising with reasonable payback not exceeding 3 years. However, a more detailed economic study is needed in order to understand the possibility of implementing the proposed study in the Ammonia process taking into account other costs not only the fixed and operating cost of exchangers, but also the piping and instrumentation costs and other aspects like, safety and environment.

Finally, a GCC (Grand Composite Curve) was constructed in order to know the exact distribution of the cooling utility needed based on shifted process temperatures. It was concluded from the GCC that although the cooling water is the cheapest among all available three utilities (boil feed water, cooling water, and refrigerant), BFW is used more than the other two to remove more load. This can be referred to the thermodynamic feasibility of cooling water as it can't be used above 169 °C of process side temperature. Table I illustrates the three utilities numbered according to Fig. 9.

TABLE I
TABULATION OF UTILITIES RELATIVE LOADS ON GCC

#	Type of Coolant	Load Removed (kW)
1.	Boiler Feed Water	183,828.4
2.	Cooling Water	69,146.7
3.	Refrigerant	15,659.7
Total min Cooling Utility		268,634.8

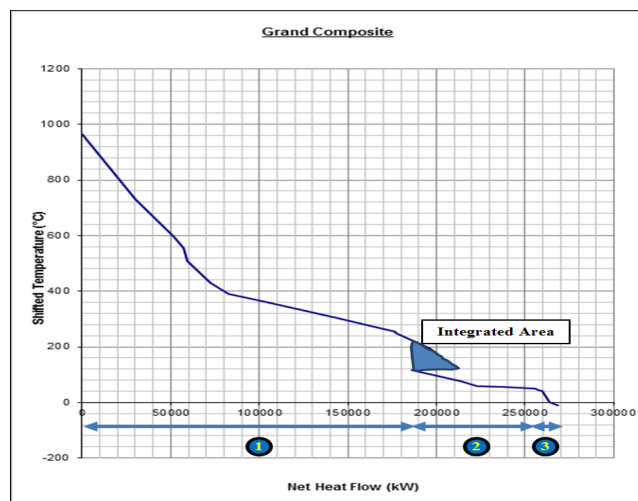

Fig. 9 Grand composite curve of UHDE Ammonia process with best utilities distribution [11]

B. Waste Heat Recovery Analysis

Generating Different kinds of steam qualities is a common practice in waste heat recovery analysis. The procedure begins with the simulation cases on HYSYS software for the primary reformer potential site. It was analyzed and the specifications of flue gases are noted down. Then, a heat exchanger was simulated on HYSYS software between flue gases stream resulted from previous HYSYS case, and boil feed water converted to the needed type of pressurized steam. This procedure illustrated that considerable amount of HP (high pressure) steam and LP (low pressure) steam can be recovered from discharged flue gases at reforming section.

Recovered amounts of high and low pressure steams from heat integration and waste heat recovery analysis can be matched with utilities requirements of pressure steam for current Ammonia process based on prior energy balance analysis, and percentage of saving in pressure steam utility for current Ammonia process is calculated. Fig. 10 summarizes the steam saving after the optimization analysis.

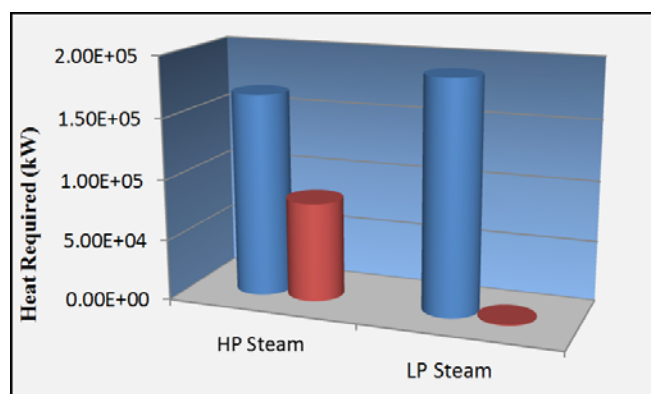

Fig. 10 Summary of steam savings after optimization analyses

VI. CONCLUSION

Heat integration for studied UHDE Ammonia process was successfully done with dexterity using specialized Excel

spreadsheet prepared by IChemE (American Institute of Chemical Engineers). It was done using the minimum temperature difference of 10 °C specified for all shell and tube heat exchangers. The two methods were used namely pinch analysis and cascading method, in which the following outcomes were gathered: 268,714.30 kW of cooling utility without any need for heating utility, in which it was realized as threshold pinch problem, and the pinch point was located at interval temperature of 965 °C. Hot and cold streams were matched with considerable flexibility as they lie far away below the pinch. One feasible heat exchange network (HEN) option was investigated while it is subjected to several internal constraints denoted by: assigned minimum temperature difference, economic indicators, and allocation of heat exchangers to anticipated area.

The Waste Heat Recovery Analysis was successfully done with HYSYS software. Heat exchangers were simulated based on boil feed water (BFW) and three types of steam, at which the flowrate was manipulated for each steam quality generation case. HP and LP Steams required for the Ammonia process were reduced by approximately 40% and 0.40%, respectively. Brining attention that LP steam generated was controlled carefully to meet environmental regulations of Qatar for discharged flue gases from stacks. The Analysis done resulted in reduction of pollution, reduction of consumption of resources and most importantly reduction in capital, operating and process costs.

The proposed HEN for UHDE Ammonia plant was subjected to economic evaluation to verify its feasibility of construction in reality. Depending on most modern methods of economic evaluation denoted by latest cost/heat transfer area charts and the famous factorial method, all matching among anticipated heat exchangers were realized within highly promising timeline with payback periods below than 3 years.

The study concluded significance of heat integration and waste heat recovery is very high in terms of a sustainable future. Implementing these optimizations did not only optimize the process whereas it reduced the cost and damage to the environment as well. It also helped in designing processes which use lesser amount of valuable resources in the meanwhile occupies smaller space. All these factors play an important role in developing a sustainable future. It can be concluded that the Ammonia process has to be modified according to the analysis done so that it would become an effective and a sustainable one.

In a word, it can be concluded that studied UHDE Ammonia process was realized to be a promising heat optimization project for Qatar, However, still it is strongly recommended to extend the scope of this work to include all other streams which were not considered as to comply with IChemE spreadsheet requirements. Moreover, the waste heat recovery should include the external boiler in utilities section where the required steam for the process is generated.

ACKNOWLEDGMENT

Appreciable thanks are sent to Texas A&M University for offering Sustainable Design course as elective course for Chemical Engineering Master's program. Also, special thanks are sent to supervisor of the study Prof. Mahmoud Elhalwagi for giving the opportunity to graduate students the exposure to real industrial applications, and have the chance to translate their knowledge in chemical engineering generally and optimization specially into effective and valuable decisions serving to improve the performance of real process.

REFERENCES

- [1] El-Halwagi, M. M., "Sustainable Design through Process Integration: Fundamentals and Applications to Industrial Pollution Prevention, Resource Conservation, and Profitability Enhancement", Butterworth-Heinemann/Elsevier, Amsterdam (2012).
- [2] Mann, J. (1999). Process Integration: Unifying Concepts, Industrial Applications and Software Implementation.
- [3] QAFCO. QAFCO Becomes World's Largest Ammonia and Urea Producer. Retrieved on July 26, 2012. From: http://www.qafco.com/qafco_becomes_worlds_largest_ammonia_and_urea_producer.html.
- [4] Hydrocarbon Processing. (2005). Petrochemical Processes 2005. (PDF version of document downloaded September 26, 2010).
- [5] Cengel, A. Y. & Boles, A. M. (2007). Thermodynamics. 6th Edition. Mc Graw Hill: New York, USA.
- [6] Daghsh, S. (Personal Communication). Energy Saving & Recovery Handout. Chemical Engineering Department. Qatar University. March 10, 2011.
- [7] Sinnott, R. & Towler, G. (2009). Chemical Engineering Design. 5th Edition. Elsevier: Burlington, USA.
- [8] Eljack, T. F. (Personal Communication). Chemical Engineering Department. Qatar University. March 20, 2011.
- [9] Yoon a, S., Lee b, J., & Park, S. (2006). Heat integration analysis for an industrial.
- [10] Matsuda a, K., Hirochi a, Y., & Tatsumi b, H. (2009). Applying heat integration total site based pinch technology to a large industrial area in Japan to further improve performance of highly efficient process plants. Tim Shire.
- [11] American Institute of Chemical Engineers - IChemE Heat Integration Excel Spreadsheet – 2012.