

Noise Depressed in a Micro Stepping Motor

Bo-Wun Huang, Jao-Hwa Kuang, J.-G. Tseng, and Yan-De Wu

Abstract—An investigation of noise in a micro stepping motor is considered to study in this article. Because of the trend towards higher precision and more and more small 3C (including Computer, Communication and Consumer Electronics) products, the micro stepping motor is frequently used to drive the micro system or the other 3C products. Unfortunately, noise in a micro stepped motor is too large to accept by the customs. To depress the noise of a micro stepped motor, the dynamic characteristics in this system must be studied. In this article, a Visual Basic (VB) computer program speed controlled micro stepped motor in a digital camera is investigated. Karman KD2300-2S non-contact eddy current displacement sensor, probe microphone, and HP 35670A analyzer are employed to analyze the dynamic characteristics of vibration and noise in a motor. The vibration and noise measurement of different type of bearings and different treatment of coils are compared. The rotating components, bearings, coil, etc. of the motor play the important roles in producing vibration and noise. It is found that the noise will be depressed about 3~4 dB and 6~7 dB, when substitutes the copper bearing with plastic one and coats the motor coil with paraffin wax, respectively.

Keywords—micro motor, noise, vibration

I. INTRODUCTION

IN the electronic, aerospace and later biomedical industry, the micro motor was employed to drive micro and high precision system. Since Trimmer [1], many investigations develop successively different kinds of electrostatic micro motors, top-drive motor, side-drive motor, etc. in micro engineering application [2, 3]. Recently, more and more researchers [4-9] turned their attentions to analyze or simulate the dynamics of micro motor. Experimental and finite element analyses were also employed to investigate or simulate the dynamics or profiles of micro motor [10-12]. Almost all of the above mentioned papers are focused on the design, dynamics of micro motor. Besides the dynamics, design and simulation for a micro motor; the noise has been study by few researchers [13]. More and more noise problems of micro motor system or higher precision 3C products become significantly annoying and needed to be depressed. Because of small space found in a micro motor, most of methods for depressing noise can not be employed, such as noise source isolation. Therefore, the relation between vibration and noise analyses investigated to depress the noise is employed in this article. Stepper motors are usually employed in precision positioning applications. In many applications, stepper motors have been also used extensively in open-loop controls. Because of the specific mechanical

structure and related magnetic circuits, a stepping motor is very different from conventional motors. Among the motor researches, Ishikawa et al. studies on static-torque characteristics of a permanent magnet (PM) type stepping motor with claw poles [14]. For the stepping motor, Kawase pays attentions on the analysis on three-dimensional dynamic step response [15], and the dynamic characteristics affected by the tooth shape are studied by Liu et al. [16]. In this paper, the noise of a micro permanent-magnetic (PM) stepping motor with claw poles is analyzed via vibration analysis.

As the system is miniaturized, the vibration, dynamic properties and noise change significantly hence affect the precision and performance of system, especially for micro motors. Recently, some investigations turn the attention to these micro system problems [17-21]; however, most studies are focused to the design, performance and so on. Few investigations pay the attention to the dynamic characteristics of a micro system, even though the dynamic property may change the system performance significantly. Due to the above mentioned reason, the vibration and noise are focused to study. In this article, the experimental analyses of both vibration and noise are employed to examine the dynamic characteristics of a micro motor. Depressing noise in micro motor operating process is one of the major aim in this study. The coherence between vibration and noise analysis to depress the noise of a micro motor is considered

II. VIBRATION AND NOISE ANALYSIS AND EXPERIMENTAL SETUP

Vibration and noise are usually found in actual engineering application when a motor is working. Generally, the noise or vibration is proportioned to the power of motor, however they are unpleased. In general size motor, by isolating and enclosing the sources of vibration and noise is widely employed to reduce the problems. The above isolating and enclosing technologies are not longer suitable for the micro size motor since no more space left in a micro motor. In order to depress the noise of a micro motor, by understanding the performance and dynamic characteristics of this motor is must. Due to the coherence between the vibration and noise, the dynamic characteristics, vibration is studied to depress the noise of a micro motor in this work. By employing the vibration analysis, the solutions may be found to depress the noise of a micro motor. Besides, the control program of this stepping motor is also revised to depress the noise.

Bo Wun Huang, Professor, Cheng Shiu University, Kaohsiung 83347, Taiwan (corresponding author, phone: +886-7-7310203; fax: +886-7-7310213; e-mail: huangbw@csu.edu.tw).

Jao-Hwa Kuang, Professor, National Sun Yat-sen University, kaohsiung 8042, Taiwan (e-mail: kuang@mail.nsysu.edu.tw).

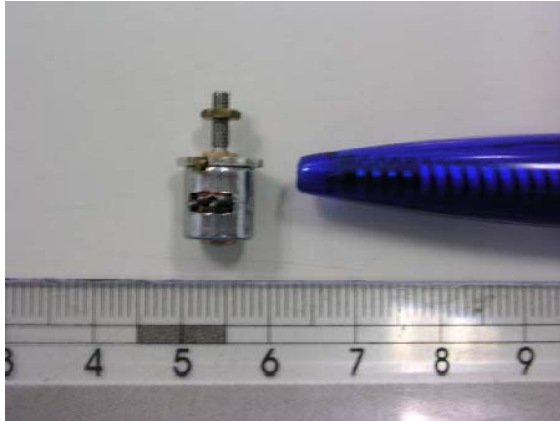

Fig. 1 A photograph of the micro motor.

The purpose of this investigation is to suppress the noise and vibration of a micro stepping motor. First, the vibration of the micro motor in different operation conditions is measured. Comparing the variation of vibration amplitudes in different operation conditions, some of important parameters on vibration can be found and accordingly, some solutions to depress the vibration of the micro motor are found. In order to investigate the noise of a micro motor, the vibration in a micro motor must be understood before depressing the noise of a micro motor. It is very difficult to measure the vibration of a micro motor, because of the micro scale. A non-contact dynamic displacement sensor is employed in this work. Besides study in the vibration, an investigation on noise of a micro motor is also the aim. Figure 1 shows the photograph of the micro motor to be measured. It is a permanent magnet type stepping motor with claw poles and is usually

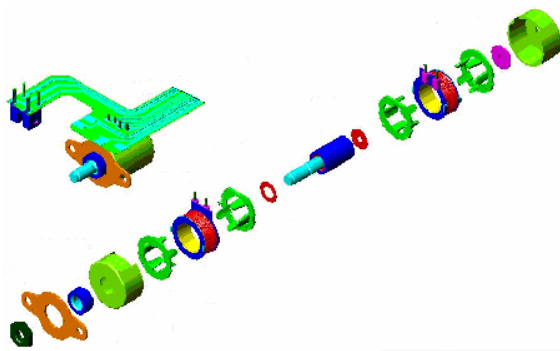
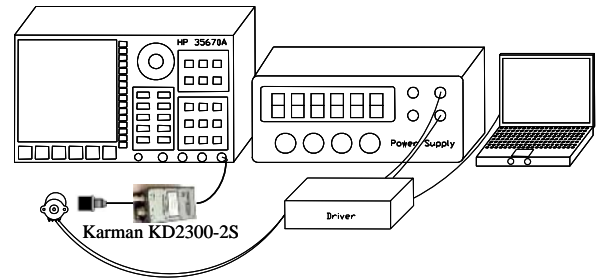
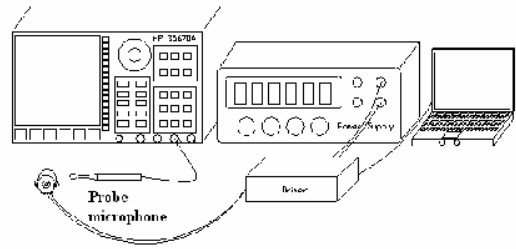

Fig. 2 A exploded diagram of the micro motor (including bearing, coil spindle, housing, etc.)



(a) Vibration measurement using non-contact Karman KD 2300 sensor



(b) Noise measurement using probe microphone

Fig. 3 The setup of vibration and noise experimental analysis

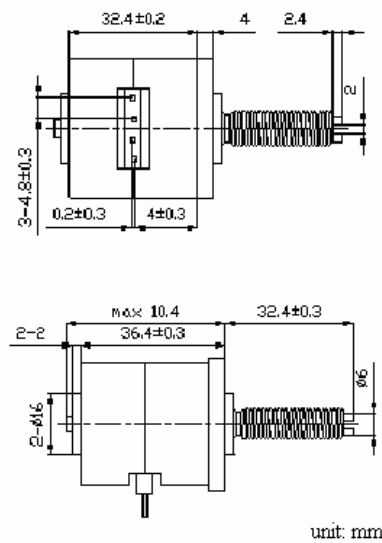

Fig. 4 Geometry of a micro motor

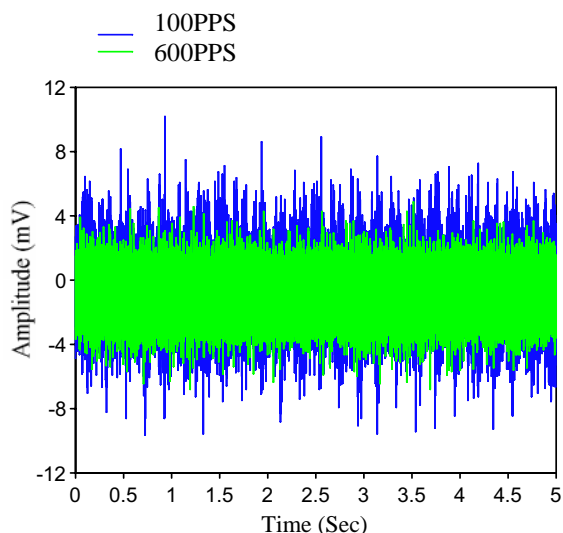

Fig. 5 Time domain vibration of a micro motor with different rotational speed

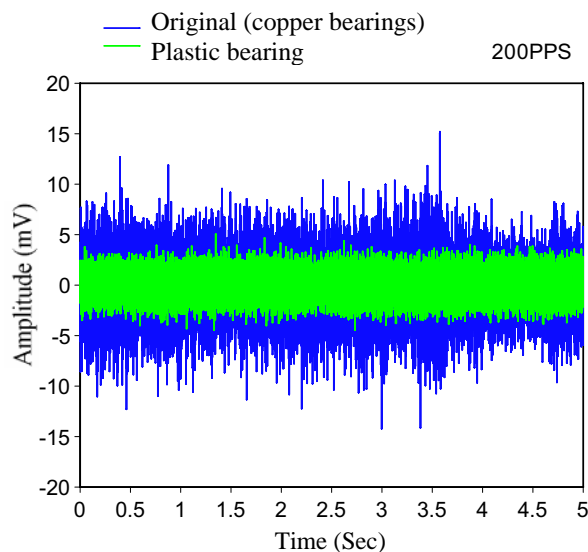

Fig. 7 Vibration of a micro motor with different bearing type

employed to drive the lens system of digital camera, but its noise and vibration is too large to be accepted by customers. To find the solution for noise and vibration to be depressed, the components and structure of micro motor must be studied. These components and assembly arrangement are shown in Fig. 2, including the bearing, coil spindle and housing, etc. According to these components in this figure and results from investigation, the important effect component on noise and vibration in a micro motor can be found to depress the noise and vibration. Because of micro scale of the motor, the vibration is too small to be measured by acceleration meter. Hence, a non-contact eddy current displacement measurement sensor, KAMAN KD2300-2S, is employed to measure vibration amplitude in a micro motor. For this vibration measurement, the

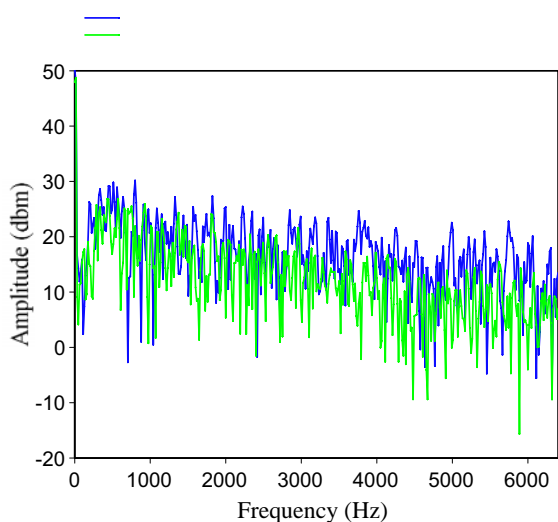

Fig. 6 Frequency domain of a micro motor with different rotational speed

experimental analysis setup sketch is displayed in Fig. 3 (a). This non-contact KAMAN KD2300-2S sensor's signal which is enlarged by a signal amplifier is then transferring the vibration data to a HP 35670A spectrum analyzer. For the same reason, the similar experiment is setup for the noise measurement in this work as shown in Fig. 3 (b). Because of micro scale for this motor, a probe microphone is employed to measure the sound pressure variations of a micro stepping motor. Similarly, the sensor signal is transferred, calculated, and analyzed by this spectrum analyzer HP35670A.

III. RESULTS AND DISCUSSIONS

The noise in a micro motor was investigated in this study. For this investigation, a micro stepping motor, type No. SP8M15RLX, is selected to study. Some geometrical parameters in a sketch of the micro stepping motor are displayed in Fig. 4. This stepping motor is always used to drive the lens

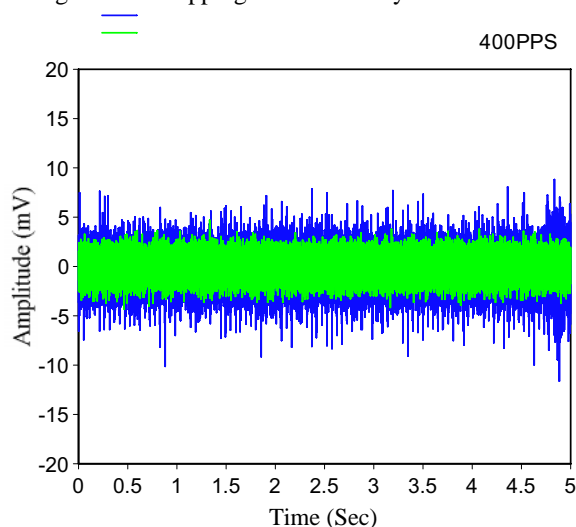

Fig. 8 Vibration of a coil blanketed with or without wax in a micro motor

system of digital camera. To amend the micro motor quality, the noise of micro motor must be depressed, so the investigation in noise of micro motor is necessary to pay the attention on this problem. To find the solution for noise of a micro motor, the vibration analysis for this micro motor is necessary. For a micro motor, the spindle with a high rotating speed is a must, therefore, the rotating speed parameter is considered to study first. The variation in vibration of a micro motor with different rotating speed is illustrated in Fig. 5. In this study, the PPS, pulse per second, represents the unit of rotating speed. Time response of a micro motor with different rotating speed is plotted in this figure. In this figure, the vibration amplitude of a micro motor at higher speed, 600 PPS, is smaller than the motor at lower rotating speed, 100 PPS. Results indicate that the time response vibration amplitude of the micro motor is increased as its rotating speed is decreased. Figure 6 shows the frequency response of a micro motor. In the frequency domain, the vibration amplitude is decreased if the micro motor increases its speed in full frequency domain. As Figs. 5 and 6, it is found that the vibration amplitude is decreased as the motor increases its rotating speed both in time and frequency domains.

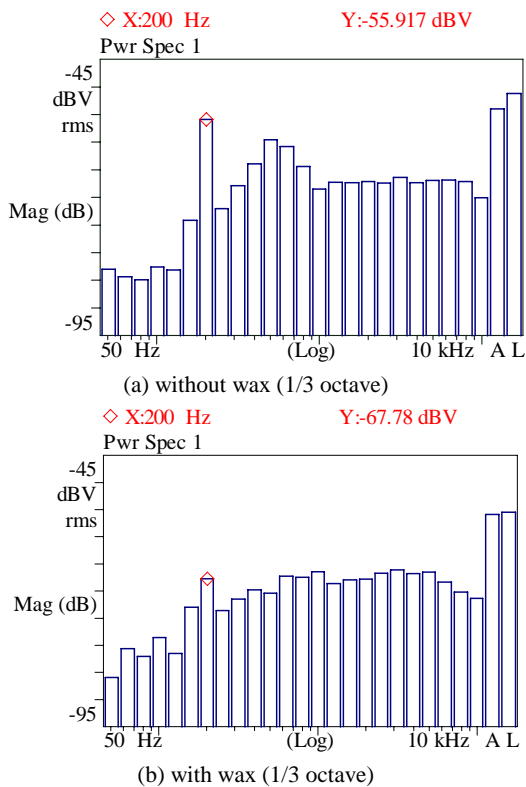

Fig. 9 Noise of a coil blanketed with or without wax at 200 PPS

From these results, the vibration amplitude is dependent on rotating speed. From the above analysis results, some rotating components in the micro motor may enlarge the vibration amplitude, so is the noise. It is clear that the rotating components may affect the vibration and noise significantly. Both bearings and coil, which are the important rotating components in this micro motor, are studied in this work. First,

TABLE I
 NOISE OF A MICRO STEPPING MOTOR WITH DIFFERENT BEARINGS

Ambience noise 30dB		
condition rotating speed	Original, (With copper bearings)	With plastic bearings
100pps	64	62
200pps	64	61
300pps	59	56
400pps	58	56
500pps	58	54
600pps	57	53
700pps	57	53
800pps	54	52
900pps	52	50

TABLE II
 NOISE OF A MICRO STEPPING MOTOR WITH AND WITHOUT WAX

Ambience noise 30 dB		
Condition rotating speed	Original (without wax)	with wax
100pps	64	58
200pps	64	56
300pps	59	54
400pps	58	52
500pps	58	52
600pps	57	50
700pps	57	48
800pps	54	46
900pps	52	46

effect of bearing on vibration amplitude is considered. Vibration amplitude of a micro with different bearings is illustrated in Fig. 7. In the studied micro motor, the original copper bearings are usually employed to support the rotating spindle of motor. The plastic bearings, material PB9T, are the substitute bearings expected to reduce the vibration amplitude. In this figure, the vibration amplitude of a motor with the plastic bearings is much smaller than with the copper bearings. It is observed that the vibration amplitude is depressed significantly by using the plastic bearing in a micro motor. Besides, the effect of coil on vibration of a micro motor is also considered in this investigation. Figure 8 shows the variation on vibration of a coil with or without paraffin wax in a micro motor. The vibration of a coil with wax is smaller than the one without wax. From this result, the coil with paraffin wax will depress the vibration of a micro motor. The rotating important components for a micro motor, bearing and coil are considered to study previously. For the micro motor, different type of bearings and different treatment of coils affect vibration significantly. Because of the

strong relativity between vibration and noise, the above effects of bearing and coil are also considered to depress the noise. Table I shows the noise of a micro motor with different bearings. These experimental results are measured in semi-anechoic room of which ambience noise is about 30 dB. The measurement distance from microphone to micro motor is 50 mm. From these results, the noise is also dependent on the rotating speed, similar to the vibration. Noise of a micro motor is decreased as the rotating speed is increased. In this table, the noise of a micro motor with plastic bearings is much smaller than the motor with copper bearings, original type, about 3~4 dB is found. Results indicate that the noise of a micro motor will be depressed if this motor with plastic bearings. Table 2 displays the variation of noise of a coil with or without the wax in a micro motor. It is found that the noise will be depressed about 6~7 dB as the coil with wax. As the above investigation, the effect bearing and coil may affect both the vibration and noise significantly in a micro motor. Finally, the sound pressure frequency response is illustrated in Fig. 9. In this figure, the 1/3 octave band is used. Figure 9(a) shows that a main noise peak at 200Hz is found as this micro motor coil without wax. As the motor coil with wax, this peak also at 200Hz but shorten significantly is observed. The phenomena, which the noise is depressed significantly as the motor coil with wax shown in Fig. 9 are identical with the data shown in Table II.

IV. CONCLUSIONS

Noise of a micro motor was investigated. The major conclusions drawn from the analysis and numerical results obtained in this study are summarized as follows:

- (1) A study of the vibration of the micro motor is necessary to depress this motor noise. The vibration of a micro motor which depends on rotating speed is observed. It is clear that the rotating components may affect the vibration and noise drastically.
- (2) It is found that the rotating components such as bearings and coil affect the vibration and noise significantly.
- (3) Results indicate that the plastic bearing and a coil with wax drastically depress the noise and vibration of a micro motor.

ACKNOWLEDGMENTS

The authors would like to thank the National Science Council, Taiwan, Republic of China, for financially supporting this research through Grant NSC 99-2632-E-230-001-MY3.

REFERENCES

- [1] Trimmer W, Gabriel KL. Design consideration for a practical electrostatic micromotor. *Sensors and Actuators* 1987; 11: 189–206.
- [2] Dhuler VR, Mehregany M, M. Phillips S. A comparative study for harmonic side-drive micromotor. *IEEE Trans Electron Devices* 1993; 40: 1985–9.
- [3] Trimmer W, Jebens R. Harmonic electrostatic motor. *Sensors and Actuators* 1989; 20: 17–24.
- [4] Muller RS. Microdynamics. *Sensors and Actuators A* 1990; 21–23: 1–8.
- [5] Bart SF, Mehregany M, Tavrow LS, Lang JH, Senturia SD. Electric micromotor dynamics. *IEEE Transactions on Electron Devices* 1992; 39(3): 566–75.

- [6] Pelikant A, Wiak S, Komezka K. Computer simulation of dynamic states of the silicon micromotor. *Int J. Comput Math Elect Electron Eng* 1998; 7: 307–12.
- [7] Endemano A, Fourniols JY, Camon H, Marchese A. VHDL—AMS modelling and simulation of a planar electrostatic micromotor. *J Micromech Microeng* 2003; 13: 580–90.
- [8] Dufour I, Sarraute ES, Abbas A. Optimization of the geometry of electrostatic micromotors using only analytical equations. *J Micromech Microeng* 1996; 6: 108–11.
- [9] Sangster AJ, Samper VD. Accuracy assessment of 2-D and 3-D finite-element models of a double-stator electrostatic wobble motor. *J Micromech Microeng* 1997; 6: 142–50.
- [10] Tai YC, Muller RS. Frictional study of IC-processed micromotor. *Sensors and Actuators* 1990; 21: 180–3.
- [11] Beerschwinger U, Milne NG, Yang SJ, Reuben RL, Sangster AJ, Ziad H. Coupled electrostatic and mechanical FEA of a micromotor. *J Microelectromech Syst* 1994; 3: 162–71.
- [12] Beerschwinger U, Reuben RL, Yang SJ. Frictional study of micromotor bearings. *Sensors and Actuators A* 1997; 63: 229–41.
- [13] Chu X, Xing Z, Gong W, Li L, Gui Z. Vibration analysis of stepping piezoelectric micro-motor using wiggle mode. *Materials Science and Engineering B* 2003; 99(1-3): 306–8.
- [14] Ishikawa T, Takakusagi R, Matsunami M. Static Torque Characteristics of Permanent Magnet Type Stepping Motor with Claw Poles,” *IEEE Trans. on Magnetics* 2000; 36 (N4): 1854–7.
- [15] Kawase Y, Takehara A. 3-D Dynamic Step Response Analysis of Claw-poled Stepping Motors by Finite Element Method. *Digest of IEEE CEFC’98*, 1998; 214.
- [16] Liu CP, Li YC, Liu KH, Wu KT, Yao YD. Analysis of the performance of permanent magnetic stepping motor with trapezoid stator tooth. *J. Appl. Phys* 2006; 99: 08R316.
- [17] Zaman MT, Kumar AS, Rahman M, Sreeram S. A three-dimensional analytical cutting force model for micro end milling operation. *International Journal of Machine Tools & Manufacture* 2006; 46: 353–66.
- [18] Michael PV, Shiv GK, Richard ED. On the modeling and analysis of machining performance in micro-endmilling, part II: cutting force prediction. *ASME, Journal of Manufacturing Science and Engineering*, 2004; 126: 695-705.
- [19] Chae J, Park SS, Freiheit T. Investigation of micro-cutting operations. *International Journal of Machine Tools & Manufacture* 2006; 46: 313–32.
- [20] Kim CJ, Mayor JR, Ni J. A Static Model of Chip Formation in Microscale Milling. *ASME, Journal of Manufacturing Science and Engineering* 2004; 126:710-8.
- [21] Tansel IN, Arkan TT, Bao WY, Mahendrakar N, Shisler B. Tool wear estimation in micro-machining. part I: tool usage-cutting force relationship. *International Journal of Machine Tools & Manufacture*, 2000; 46: 313–32.

Bo Wun Huang received the B.S. and M.S. degrees in Mechanical Engineering from National Taiwan University of Science and Technology, Taipei, Taiwan, R.O.C., in 1991 and 1993, respectively, and the Ph.D. degree in mechanical engineering from the National Sun Yat-sen University, Kaoshiung, Taiwan, in 1999.

Jao Hwa Kuang received the B.S. degree in mechanical engineering from National Cheng Kung University, Tainan, Taiwan, R.O.C., in 1970, and the Ph.D. degree in mechanical engineering from the University of Cincinnati, Cincinnati, OH, in 1983.

J.-G. Tseng J.-G. Tseng received the B.S. degrees in Shipbuilding Engineering from Chung Cheng Institute of Technology, Taoyuan, Taiwan, R.O.C., in 1980. He received the M.S. and Ph.D. degree in Mechanical Engineering from University of Washington, Seattle, and Carnegie Mellon University, Pittsburgh, U.S.A., in 1987 and 1996, respectively. He currently is a Associate Professor of the Department of Mechanical Engineering, Cheng Shiu University, Kaoshiung, TAIWAN. His primary research focuses in the area of vibration, fluid structured coupled system, biomechanics

Yan-De Wu received the B.S. degrees in Mechanical Engineering from Cheng Shiu University, Kaoshiung, Taiwan, R.O.C. He received the M.S. degree also in Department of Mechanical Engineering, Cheng Shiu University, Kaoshiung, TAIWAN. His primary research focuses in the area of vibration, micro system