

Modelling of a Multi-Track Railway Level Crossing System Using Timed Petri Net

Prasun Hajra, and Ranjan Dasgupta

Abstract—Petri Net being one of the most useful graphical tools for modelling complex asynchronous systems, we have used Petri Net to model multi-track railway level crossing system. The road-way has been augmented with four half-size barriers. For better control, a three stage control mechanism has been introduced to ensure that no road-vehicle is trapped on the level crossing. Timed Petri Net is used to include the temporal nature of the signalling system. Safeness analysis has also been included in the discussion section.

Keywords—Modelling, Timed Petri Net, Railway Level Crossing, Safeness Condition.

I. INTRODUCTION

RAILWAY level crossing is one of the most critical points to control in the railway system from the safety point of view. It is the place where a railway and a road cross each other on the same level and naturally, if not controlled properly, it may lead to severe loss of life and property both.

A multi-track railway level crossing system (LX system hereafter) is very complex, safety-critical in nature and modelling such a system [3], [7] is a very wide-spread research activity among the researchers of all over the world. The LX system consists of the LX Physical Components managed by the LX Control Unit. LX Barriers, LX Road Signal and LX Rail Signal are the three major physical components of the LX system. Several modelling tools have been developed and used for modelling such complicated systems. Petri Net [1], [2], [3], [8] is one of such tools used for quite some time to model various asynchronous systems including LX system.

In [5], Ghazel and Kurosi have modelled the various functional requirements of automatic level crossing systems [11]-[14]. However, they have confined their work to single track and only in case of one direction. Also they have not considered the situation of more than one consecutive trains coming on the same track in the same direction within a short period of time.

In our research work Timed Petri Net [4] has been used to model the operations of the multi-track railway level crossing system allowing flow of railway traffic from both the directions – left-to-right and right-to-left.

Prasun Hajra, Ex-student, Dept. of Computer Sc. & Engg., National Institute of Technical Teachers' Training & Research, Kolkata, India (e-mail: prasun.hajra@gmail.com).

Ranjan Dasgupta, Dept. of Computer Sc. & Engg., National Institute of Technical Teachers' Training & Research, Kolkata, India (e-mail: ranjandasgupta@hotmail.com; ranjandasgupta@ieee.org).

Section II of this paper contains a basic discussion on Petri Nets and Timed Petri Nets. Description of the physical components of a multi-track railway level crossing is included in Section III. Section IV contains the operational description of the components of the multi-track railway level crossing system. The Timed Petri Net models of the major components of the LX system are given in section V and section VI contains the discussion on safeness of the models.

II. OVERVIEW OF PETRI NETS

Petri Net is a formal modelling technique, developed in the early 1960s by Carl Adam Petri. It is a graphical modelling tool with a mathematical foundation. Petri Nets are mainly used to describe and analyze the concurrent, asynchronous, parallel, distributed and non-deterministic systems.

A Petri Net model consists of places (represented as circles), transitions (represented as rectangular bars/boxes) and arcs directed from either places to transitions or transitions to places (representing flow relations). Arcs are labelled with weights. Generally, the labels for unit weights are not shown explicitly. A place from which a directed arc goes to a transition is called an input place of that transition. On the other hand, a place to which there is a directed arc from a transition, is called an output place of that transition.

A Petri Net is given a state by marking its places with tokens (represented as small solid circles or dots inside a place). A marking M is a function that assigns to each place a non-negative integer representing the number of tokens present in that place.

Petri Net is formally defined as a 5-tuple $PN = (P, T, F, W, M_0)$ where

1. $P = \{p_1, p_2, \dots, p_m\}$ is a finite set of places,
2. $T = \{t_1, t_2, \dots, t_n\}$ is a finite set of transitions with $P \cup T \neq \emptyset$ and $P \cap T = \emptyset$,
3. $F \subseteq (P \times T) \cup (T \times P)$ is a set of arcs,
4. $W: F \rightarrow \{1, 2, 3, \dots\}$ is a weight function and
5. $M_0: P \rightarrow \{1, 2, 3, \dots\}$ is an initial marking.

Where, $(P \times T)$ and $(T \times P)$ are the Cartesian Products of the finite sets P & T .

By changing the distribution of tokens in the places (i.e., by different sequences of marking), the occurrence of events (i.e., transitions) or execution of operations can be reflected. The following rules are used to govern the flow of tokens.

Transition Enabling Rule:

(a) A transition 't' is said to be enabled if each input place ' p_{in} ' of that transition 't' contains at least the number of

tokens equal to the weight of the directed arc connecting 'p_{in}' to 't'.

Transition Firing Rule:

- (a) For firing of a transition 't', it should be enabled.
- (b) Firing of an enabled transition 't' removes from each input place 'p_{in}' the number of tokens equal to the weight of the directed arc connecting 'p_{in}' to 't'. It also deposits in each output place 'p_{out}' the number of tokens equal to the weight of the directed arc connecting 't' to 'p_{out}'.

Amongst the limitations of PN [3], we may note that---

- (a) The tokens are anonymous i.e., the presence of a token in a place may denote only the presence of a message in a buffer, not what the message says.
- (b) The selection policy between more than one enabled transitions cannot be determined through PN models.
- (c) PN cannot handle the timing issues (critical aspects for some systems).

Timed Petri Net (TPN) [4] has been introduced to overcome the temporal limitation of the Petri Net (PN). TPN represents the temporal constraints of the behaviour modelled in an explicit way.

In TPN, a token in an input place 'p_{in}' of the transition 't' is taken into account as "live" only within the stipulated time interval [t_{min}, t_{max}] of 't'. After the duration t_{max}, the token is treated as "dead". That is, presence of the required number of tokens in each of the input places (p_{in}'s) is to be ensured within [t_{min}, t_{max}] to make the transition enabled. Even the failure of a single place to acquire the required number of tokens within [t_{min}, t_{max}] will prevent the enabling of the transition. After t_{max}, all the tokens still present in the input places of 't' (either left after firing of 't' or still in the un-enabled state) will be disabled.

III. DESCRIPTION OF THE PHYSICAL COMPONENTS OF A MULTI-TRACK RAILWAY LEVEL CROSSING SYSTEM

LX Physical Components include the various things required [5], [6], [9], [10] to protect the railways from any collision between road and rail traffic on the level crossings. Barriers, road signals, rail signals, various sensors, warning devices etc. are the physical components of the LX System. In the proposed system, the majorly used physical components viz.-2-Part LX Barriers (consisting of Arriving Part and Leaving Part), LX Road Signal (consisting of green, red and amber lights) and LX Rail Signal (consisting of red and green lights) of a railway level crossing with n tracks (say, Track-1, Track-2, ..., Track-n) have been shown in Fig. 1. Proper sequential functioning of all these physical components of the LX becomes very much necessary for uninterrupted railway traffic movement on the level crossings and it is the responsibility of the LX Control Unit to perform an overall management of the LX Physical Components to ensure the smooth railway traffic movement on the level crossings in no-fault situations. Table I gives a description of the various terms used in this writing.

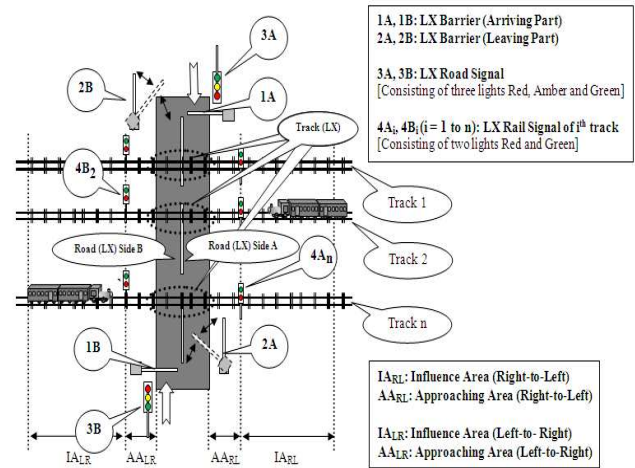

Fig. 1 Description of Multi-Track Railway Level Crossing

TABLE I
 DESCRIPTION OF THE TERMS USED

Sl. No.	Terms	Description
1	LX	A place where a multi-track railway and a road cross at the same level.
2	Road (LX)	Portion of the road in the LX. That is, portion of the road within the two 2-Part LX Barriers (defined in serial no. 11). It consists of Road (LX) Side A and Road (LX) Side B as shown in Fig. 1.
3	Track (LX)	Portion of the railway tracks in the LX (refer to Fig. 1).
4	LX System	Consists of LX Physical Components and LX Control Unit.
5	LX Physical Components	Things used (e.g., LX Road Signal, LX Rail Signal, 2-Part LX Barrier etc.) to avoid collisions between road and rail traffic on the LX.
6	LX Control Unit	Controls the working sequence of all the LX Physical Components.
7	Influence Area	A fixed area before the LX Rail Signal (defined in serial no. 10) represented as IA _{LR} and IA _{RL} in Fig.1. Whenever a train enters into the Influence Area, the count in the Approaching Request Buffer (defined in serial no. 16) corresponding to that track and direction is increased by 1 (one) and the closing activities of the 2-Part LX Barriers are initiated.
8	Approaching Area	The area in between the LX Rail Signal and the LX (represented as AA _{LR} and AA _{RL} in Fig. 1). A train may enter into the Approaching Area only when the green light of the LX Rail Signal starts flashing.
9	LX Road Signal	Road signal (equipped with three lights – red, amber and green) placed just before each of the Arriving LX Barrier Parts (defined in serial no. 12) to control the road traffic movement on the LX. 3A and 3B in Fig. 1 represent two LX Road Signals. Green light authorizes road traffic movement, amber light works as a warning before stop and the red light signifies complete stop of road traffic movement.
10	LX Rail Signal	A rail signal (equipped with two lights – red and green with usual meaning) placed

Sl. No.	Terms	Description
		on the left hand side of the track in each direction left-to-right and right-to-left at a position where Influence Area ends and Approaching Area begins. $4A_i$'s and $4B_i$'s in Fig. 1 depict such signals.
11	2-Part LX Barrier	Consists of Arriving LX Barrier Part and Leaving LX Barrier Part. These barrier parts have three functional states – vertically raised, lowered at 45° and lowered horizontally. These barrier parts can be raised and lowered independently. In Fig. 1 (1A,2B) and (1B,2A) represent two 2-Part LX Barriers.
12	Arriving LX Barrier Part	Half barrier for restricting the road traffic to enter in the LX. 1A and 1B in Fig. 1 depict such Arriving LX Barrier Parts.
13	Leaving LX Barrier Part	Half barrier lowered horizontal after all the road traffic (entered in the LX before the lowering of the arriving part) leave the LX.
14	Train passed / crossed the LX	The train has reached to the next rail signal after passing the LX successfully within the TIME-OUT (defined in serial no. 17).
15	Train Approaching Request	Signal to the LX Control Unit generated when a train just enters in the Influence Area.
16	Approaching Request Buffer	An ($n \times 2$)-cell buffer used to keep count of the current Train Approaching Requests on all the tracks from either sides left-to-right or right-to-left (n rows in the buffer represent the n tracks and the two columns represent the two directions). All the cells in the buffer are initialized with zeros. Whenever a train enters into the Influence Area, the count in the cell corresponding to that track and direction is increased by 1 (one). After the train passes the LX, the buffer content corresponding to that train is decreased.
17	TIME-OUT	Maximum time limit within which a train is expected to cross the LX after getting green light in the LX Rail Signal in a no-fault situation.
18	DISASTER	Any situation which leads to an infinite delay in rail or road traffic movement on the LX.
19	Faulty Situation	A faulty situation arises when a train gets stuck indefinitely (at least for more than the TIME-OUT) just before the LX but after crossing the LX Rail Signal due to some mechanical fault or chain pulling.
20	Plunger	A device used by the train driver to manually send a fresh request to the LX Control Unit for lowering the 2-Part LX Barriers whenever he wants to cross the LX after recovering from a faulty situation.

IV. OPERATIONAL DESCRIPTION OF A MULTI-TRACK RAILWAY LEVEL CROSSING SYSTEM

A. At the Initial Stage (when there is no train in Influence Area and no train in Approaching Area)

1. Red flashing in all the LX Rail Signals $4A_i$ and $4B_i$ ($i = 1$ to n).

2. Green flashing in the LX Road Signals 3A and 3B.
 3. Arriving LX Barrier Parts 1A, 1B and Leaving LX Barrier Parts 2A, 2B are in raised vertical position.

B. When a Train Enters into the Influence Area

1. After first t_1 s the LX Road Signals 3A and 3B stop flashing green and start flashing amber. After next t_2 s amber lights stop and red lights start flashing.

2. After t_3 s from the flashing of the red lights in 3A and 3B, both the Arriving and the Leaving LX Barrier Parts 1A, 1B and 2A, 2B are lowered at 45° .

3. On checking that there is no road vehicle under the Arriving LX Barrier Parts 1A and 1B, both 1A and 1B are lowered to horizontal position within t_4 s. But if either of 1A or 1B cannot be lowered to the horizontal position within t_4 s, then a DISASTER (delay in rail traffic movement) is identified and the Disaster Management Force is informed.

4. After checking that there is no road vehicle on the Road (LX) Side A and Road (LX) Side B, the Leaving LX Barrier Parts respectively 2A and 2B are lowered to the horizontal position independently within t_5 s. If either of 2A and 2B cannot be lowered within t_5 s, then it is also identified as a DISASTER and it is informed to the Disaster Management Force.

5. By this time ($= t_1+t_2+t_3+t_4+t_5$ s) the train may at most reach to the LX Rail Signal (say, $4A_i$ for some i) and flashing red light in the signal stops the train in front of the LX Rail Signal $4A_i$ (if required). Within t_6 s from the horizontal lowering of the Leaving LX Barrier Parts 2A and 2B, the signal $4A_i$ stops flashing red and starts flashing green. This flashing green light in $4A_i$ authorizes the train to enter in the Approaching Area. Just after the train enters in the Approaching Area, the LX Rail Signal $4A_i$ is again turned red to prevent any other train to enter in the LX on that track before this one goes out.

6. Whenever the train enters into the Approaching Area, the fixed TIME-OUT is set for the train. In normal situation the train is expected to cross the LX before the TIME-OUT is reached. If, before the train passes the LX, another train enters into the Approaching Area through another track then the TIME-OUT is reset.

C. After the Train Crosses the LX

1. After each train crosses the LX, the Approaching Request Buffer is checked to verify whether there is any other Train Approaching Request or not. If all the cells in the buffer contain zeros (i.e., there is no other Train Approaching Request on any of the n -tracks), the barrier parts 1A, 1B, 2A and 2B are raised vertical even before the TIME-OUT is reached and 3A, 3B are turned green.

2. If at any point of time after the passing of a train it is found that some of the buffer counts are still non-zero (representing that some other trains have entered in the Influence Area within this time) the system will wait until all the approaching trains pass the LX and hence the Arriving LX Barrier Parts 1A, 1B and the Leaving LX Barrier Parts 2A, 2B will remain lowered horizontal until all the trains cross the LX and reach to a certain distance (to the next rail signal).

D. After Specific TIME-OUT

In a no-fault situation the trains usually cross the LX even before the TIME-OUT is reached and the LX barriers are raised. But, if the LX Barrier Parts remain lowered even after the TIME-OUT (corresponding to the last Train Approaching Request that was entered in the buffer) is reached, then a fault or DISASTER is identified.

1. A Faulty Situation arises when a train fails to cross the LX within the TIME-OUT for some kind of irregularity. It is a case of indefinite waiting for the train to overcome from this faulty situation. In such a situation we raise all the Arriving LX Barrier Parts 1A, 1B and Leaving LX Barrier Parts 2A, 2B to the vertical position and turn the signal green in 3A, 3B and red in 4A_i (say) after checking that there is no Train Approaching Request from any of the sides on any of the tracks and also the unsuccessful train is not on the Track (LX) (i.e., the train is not blocking the Road (LX) in any way). After authorizing the road traffic movement on the Road (LX) the unsuccessful Train Approaching Request is destroyed. When the fault is fixed, the train driver manually sends a fresh LX crossing request to the LX Control Unit using the Plunger and all the LX Barrier lowering activities are re-initiated.

2. If after the TIME-OUT such a situation appears that the train is at rest blocking the Road (LX), then it is identified as a DISASTER and the Disaster Management Force is informed. Timed Petri Net (TPN) has been chosen in this case as the most suitable modelling tool to model such a complex asynchronous system with temporal characteristics.

V. TIMED PETRI NET MODELS OF THE MAJOR PHYSICAL COMPONENTS OF THE LEVEL CROSSING SYSTEM

LX Barrier, LX Road Signal and LX Rail Signal are the indispensable parts of a level crossing. The other components [5], [6] can be various sensors, some intermediate rail signals, an audible warning device, a plunger etc. Sensors can be used to detect the arrival of a train, to identify the train in a safety-critical distance from the LX, to make sure that the train has passed the LX completely within the fixed TIME-OUT, to check the clearance of the road etc. A plunger [5] is used to manually send a new LX crossing request to the LX Control Unit from the train which was unsuccessful to cross the LX within the fixed TIME-OUT in some faulty situations.

Here we discuss the TPN models of 2-Part LX Barrier, LX Road Signal and LX Rail Signal respectively.

A. Timed Petri Net Model of 2-Part LX Barrier

The initial marking of the Timed Petri Net model of 2-Part LX Barrier (Fig. 2) shows that only the places “Arriving Parts Raised Vertical” and “Leaving Parts Raised Vertical” are marked with one token each. The enabling of the transition t_1 requires the external place “Red Flashing Start in LX Road Signal” to contain a token. The solid black boundary in the diagram defines the boundary of the system component. The external places are shown in dotted circles and the interactions with the external places are shown using dotted arrows. Upon firing of the transition t_1 in t_3 s, one token is deposited to each of the places “Arriving Parts Lowered at 45°” and “Leaving

Parts Lowered at 45°”. Now, when the “Road Status (Exactly under the Arriving LX Barrier Parts)” becomes clear (i.e., the external place acquires a token) the transition t_2 is enabled. Firing of t_2 within t_4 s puts a token in the place “Arriving Parts Lowered Horizontal”. This initiates the enabling of the transition t_3 with the clearance of the Road (LX). It results in lowering the Leaving parts horizontal within t_5 s. Then, depending on the availability of tokens in various outside places viz. 1a, 1b, 2, 3a and 3b (i.e., other external parameters) either one of the mutually exclusive transitions t_4 , t_5 and t_6 is enabled. Firing of each of the transitions t_4 and t_5 deposits one token in the external place “Red Flashing End in LX Road Signal” and causes the Arriving and Leaving Barrier Parts to be raised vertical. Firing of t_6 identifies a DISASTER.

In this work we have maintained an $(n \times 2)$ -cell buffer (known as Approaching Request Buffer) to keep necessary track of every approaching train on each of the i^{th} tracks (i runs from 1 to n) from any direction (left-to-right or right-to-left). Whenever the external places 1a and 2 acquire one token each (i.e., it is checked that the train has passed the LX and there is no other Train Approaching Request), the transition t_4 is enabled. The transition t_5 is enabled when the Track (LX) remains clear even after a train fails to cross the LX within the TIME-OUT (i.e., if the external places 1b, 2, 3a acquire tokens). Firing of both t_4 and t_5 raises the 2-Part LX Barriers vertical and stops flashing red in the LX Road Signals, which becomes the triggering factor for the enabling of the transition t_{15} (see Fig. 3 of LX Road Signal). But, if the external places 1b, 2 and 3b acquire tokens, t_6 is fired and a DISASTER is identified. If the Arriving Barrier Parts or the Leaving Barrier Parts cannot be lowered in due time, then also a DISASTER is identified (transitions t_8 and t_9) and the Disaster Management Force is informed by firing t_7 .

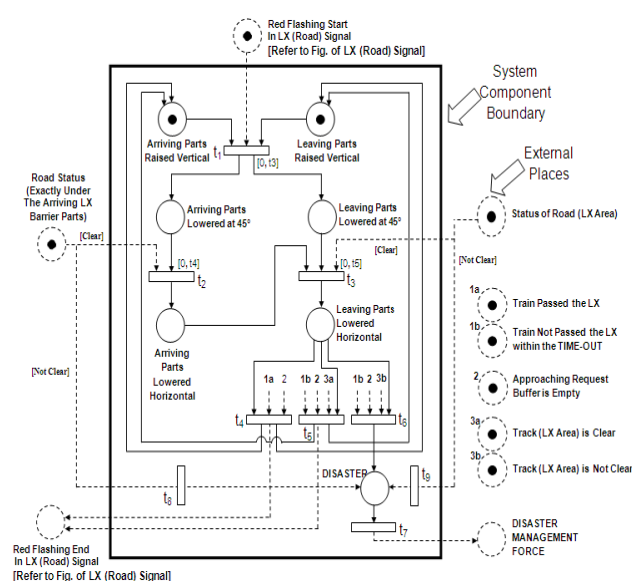

Fig 2 Timed Petri Net Model of the 2-Part LX Barrier

B. Timed Petri Net Model of LX Road Signal

The LX Road Signal is equipped with three color lights viz. -red, amber and green. Initially when there is no train detected within the Influence Area and the Approaching Area of the

level crossing, the green light flashes in the LX Road Signal signifying no restriction on road traffic movement. Fig. 3 shows the Timed Petri Net model of the LX Road Signal. The signal is activated when a train enters in the Influence Area and the transition t_{11} becomes enabled.

Firing of t_{11} just after t_1 s, extinguishes the green light and directly enables t_{12} . Upon firing t_{12} the amber light starts flashing. Firing of t_{13} turns off the amber light after t_2 s and enables t_{14} . Firing of t_{14} initiates red light flashing which in turn becomes the main triggering condition for the transition t_1 (see Fig. 2 of 2-Part LX Barriers). Firing of t_{14} also deposits a token in the place "Red Flashing End". But only after receiving a token from either t_4 or t_5 (see Fig. 2 of 2-Part LX Barriers), the transition t_{15} becomes enabled. After the firing of t_{15} the red light in the LX Road Signal starts blinking and becomes ready to authorize the green signal again through the firing of the transition t_{16} .

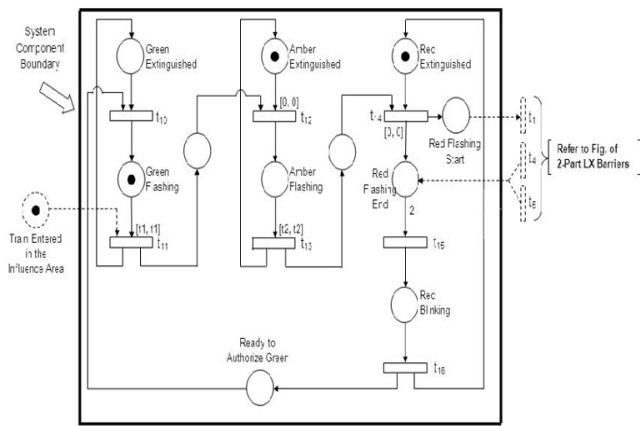

Fig. 3 Timed Petri Net Model of the LX Road Signal

C. Timed Petri Net Model of LX Rail Signal of the i^{th} Track (i runs from 1 to n)

Two LX Rail Signals are required for each track – one for each direction (left-to-right and right-to-left). The LX Rail Signal is equipped with two color lights – red and green. The operation of the LX Rail Signal is being modelled in Fig. 4 using Timed Petri Net. The initial marking of the model shows that before detection of any approaching train (i.e., before the train has entered in the Influence Area) the red light keeps flashing. Whenever a Train Approaching Request is detected on the i^{th} track (say), the Approaching Request Buffer is checked. On checking that the previous train (if any) on the i^{th} track has passed the LX successfully (i.e., the corresponding cell in the Approaching Request Buffer contains zero) and the Leaving LX Barrier Parts are lowered to the horizontal position (see Fig. 2), the transition t_{18} is enabled. Firing of which within t_6 s causes instantly extinguishing of the red light and authorizing of the green light (i.e., transition t_{19}) on that direction of the i^{th} track on which the train approaching was detected.

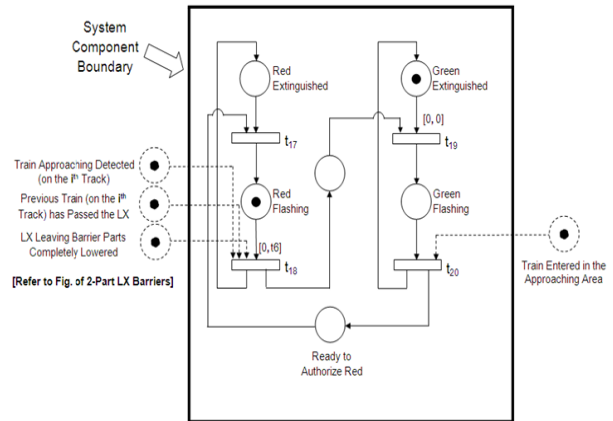

Fig. 4 Timed Petri Net Model of LX Rail Signal of the i^{th} Track (i runs from 1 to n)

At this point the signal waits for the train to enter in the Approaching Area. Whenever the train enters into the Approaching Area the green light is turned off through firing of the transition t_{20} and again the red light starts flashing on the i^{th} LX Rail Signal to restrict any other train to enter in the Approaching Area from the same direction on the i^{th} track.

VI. DISCUSSION ON SAFENESS OF THE TPN MODELS

The road and rail traffic movement near the railway level crossings has to follow a strict signalling. Table II (in the next page) gives a list of such acceptable and unacceptable situations in railway traffic movement near the level crossings. All the acceptable states/situations (shown in the table) are treated as safe with respect to the corresponding positions of the road and rail traffic. Safeness means that in such states/situations the chances of collision between rail and road traffic will never occur. On the other hand the unacceptable states represent a chance of collision between the road and rail traffic movement and naturally becomes the points of concern for us. A railway level crossing system has to ensure that these unacceptable situations are totally unreachable within the operational sequence of the system. So, now our aim is to establish that under normal situations our models will never enter to an unacceptable state within their operations. This will in turn prove the safeness conditions of the models (i.e., in zero-fault situation this system will never lead to any unsafe state/situation and even if a fault or DISATER takes place, the system will be able to identify that properly such that the required measures can be taken by the earliest).

In the leftmost column of Table II we have placed six (6) different rail traffic positions near the LX and on the topmost row of the table we have considered four (4) different road traffic positions as shown in Fig. 1. Whenever an approaching train just enters in the Influence Area, the restriction on the road traffic movement is initiated. After $(t_1 + t_2)$ s i.e., at the moment when the LX Road Signals are already turned red and the LX Barrier Lowering activities are about to start, no car can appear just under the Arriving LX Barrier Parts. If the Arriving Barrier Parts cannot be lowered in due time then it will directly interrupt the rail traffic movement. Moreover, all

the Arriving and Leaving Barrier Parts have to be lowered before the train enters within the Approaching Area (AA). So, no car can appear then on the Road (LX). This remains true until the train passes the LX successfully. If more than one Approaching Train Requests are found in quick succession then the all the barrier parts remain closed until the trains pass the LX or TIME-OUT (corresponding to the last Train Approaching Request) is reached. So, the five states/situations those have been identified as unacceptable in Table II are of highest interest to us. We will perform safeness analysis on each of the five states separately.

TABLE II
 STATES/ SITUATIONS OF RAILWAY TRAFFIC MOVEMENT NEAR THE LEVEL CROSSING

Position of the Rail Traffic	Position of the Road Traffic			
	Before the Arriving LX Barrier	Just Under the Arriving LX Barrier	Within the Road (LX)	Left the Leaving LX Barrier
Not Entered in the Influence Area	Acceptable	Acceptable	Acceptable	Acceptable
Just Entered in the Influence Area	Acceptable	Acceptable	Acceptable	Acceptable
After (t1+t2) s in the Influence Area	Acceptable	<u>Unacceptable</u>	Acceptable	Acceptable
Entered in the Approaching Area	Acceptable	<u>Unacceptable</u>	<u>Unacceptable</u>	Acceptable
On the Track (LX)	Acceptable	<u>Unacceptable</u>	<u>Unacceptable</u>	Acceptable
Crossed the LX	Acceptable	Acceptable	Acceptable	Acceptable

A. Situation when the Train has Entered in the Influence Area Already Before (T1+T2) S and the Road-Vehicle is Just under the Arriving LX Barrier Parts

This situation will never occur in our model. Because, after (t1+t2) s the LX Road signal turns red from initial green through an intermediate amber light. The barrier lowering process is activated after t3 s from when the red light starts flashing in the LX Road Signal (refer to t₁ in Fig. 2). After t3 s from the activation, first the barriers are lowered at 45° and then even after another t4 s the Arriving Barrier Parts are lowered completely horizontal (refer to t₂ in Fig. 2). So, in zero-fault situation (i.e., if no car breaks the LX Road Signal and enters in the LX when the red signal started flashing) this case is unreachable in our model.

B. Situation when the Train Has Entered in the Approaching Area and the Car Is Just under the Arriving LX Barrier Parts

This situation is completely impossible. One LX Rail Signal is placed on each side of the track where the Influence Area

ends and the Approaching Area begins. For a train to enter into the Approaching Area from the Influence Area, the LX Rail Signal has to be turned green. But unless all the barrier parts are closed (refer to t₁₈ in Fig. 4) the green light in the LX Rail Signal will never become authorized. So, in zero-fault situation (i.e., if the train driver does not break the railway signal) the train will reach to the LX Rail Signal at the most and the flashing red light will stop the train in front of the LX Rail Signal. So, this situation is also unreachable.

C. Situation when the Train has Entered in the Approaching Area and the Road-Vehicle is on the Road (LX)

It is another impossible situation in our model. It was a possible case (and very probable) when the Single-Part LX Barriers were used as there was no such prior checking mechanism to know whether the barriers have been closed or not before authorizing the LX Rail Signal green. But, in case of 2-Part LX Barriers (consisting of Arriving Part and Leaving Part) this will never happen. Because, the Leaving LX Barrier Parts will be lowered horizontal after getting a positive response that the Road (LX) is clear. Otherwise it will be treated as a DISATER (refer to t₃ and t₉ in Fig. 2). So, if there remains a road vehicle in the Road (LX) the Leaving LX Barrier Parts will not be lowered horizontal and the rail signal will never be authorized to green and hence, the train will not be able to enter within the Approaching Area in such a situation.

D. Situation When the Train is on the Track (LX) and the Road-Vehicle is Just Under the Arriving LX Barrier Parts

AND

E. Situation When the Train is on the Track (LX) and the Road-Vehicle is on the Road (LX)

These situations are completely impossible to occur in our model. We have already shown that no train can even enter within the Approaching Area if the Leaving LX Barrier Parts cannot be completely lowered and the rail signal does not turn to green. The barrier raising process in our model is also very strict and well defined. Only after getting an assurance that there is no more live train approaching request on any of the 'n' tracks and there is no blockage on the Road (LX), the barriers are raised. Hence, no car can be present under the Arriving LX Barrier Parts or within the Road (LX) when the train is on the way to cross the LX. Even if a faulty situation occurs and the train stops before the LX due to some irregularity, there are provisions in this proposed model to raise the barriers but only after checking the clearance of the Road (LX) and making the unsuccessful Train Approaching request disabled.

VII. CONCLUSION

Multi-track railway level crossing, while unmanned, is a point of concern all over the world for its possible collision. Automated systems are more and more preferred as manning for every level crossing becomes more and more expensive. As PN or TPN helps in analysis of safeness condition, we have augmented the entire system and modelled it with help of

TPN and identified the situations of possible collisions so that the same can be prevented.

REFERENCES

- [1] C. A. Petri, Kommunikation mit automaten, Bonn: Institut für Instrumentelle Mathematik, Schriften des IIM Nr. 3, 1962. Also, English translation, Communication with automata, New York: Griffiss Air Force Base. Tech. Rep. RADC-TR-65377, vol. 1, Suppl. 1, 1966.
- [2] Tadao Murata, "Petri nets: properties, analysis and application", Proceedings of the IEEE, Vol.77, No.4, April, 1989, 541-580.
- [3] Carlo Ghezzi, Mehdi Jazayeri, & Dino Mandrioli, "Fundamentals of software engineering" -second edition (Upper Saddle River, NJ 07458 Pearson Prentice Hall).
- [4] Jiaccum Wang, "Timed petri nets – theory and applications" (USA, Kluwer Academic Publishers).
- [5] M. Ghazel, & El M. El Koursi, "Automatic level crossings: from informal functional requirements' specifications to the control model design", Proc. IEEE International Conference on System of Systems Engineering, 2007, April, 2007, 1 – 6.
- [6] Michaela Huhn, Hardi Hungar, Axel Zechner, & Oliver Lemke, "Tools for the model-based development of certifiable, dependable systems: a case study", railway level crossing, Dagstuhl Seminar 07241, International Conference and Research Center, Schloss Dagstuhl, June, 2007, <http://drops.dagstuhl.de/opus/volltexte/2008/1405>.
- [7] Roger S. Pressman, "Software engineering – a practitioner's approach" - fifth edition (McGraw-Hill).
- [8] Richard Zurawski, & Meng Chu Zhou, "Petri nets and industrial applications: a tutorial", IEEE. Transactions on Industrial Electronics, Vol. 41, No. 6, December 1994.
- [9] S. Einer, R. Slovak, & E. Schnieder, "Modeling train control systems with petri nets -an operational specification, Systems", Man, and Cybernetics, 2000 IEEE International Conference, Issue Date: 2000, Volume: 5, 3207 – 3211.
- [10] M.M.Z. Horste, & E. Schnieder, "Modeling train control systems with Petri Nets -a functional reference architecture", Systems, Man, and Cybernetics, 2000 IEEE International Conference, Issue Date: 2000, Volume: 4, 3081 – 3086.
- [11] Alessandro Giua and Carla Seatzu, "Modeling and supervisory control of railway networks using petri nets", IEEE Transactions on Automation Science and Engineering, Vol. 5, No. 3, July 2008.
- [12] Alessandro Giua, & Carla Seatzu, "Supervisory control of railway networks with petri nets", Proceeding of the 40th IEEE Conference on Decision and Control, Orlando, Florida USA, December, 2001.
- [13] Fabrizio Diana, Alessandro Giua, & Carla Seatzu, "Safeness-enforcing supervisory control for railway networks", Proc. 2001 IEE/ASME International Conference on Advanced Intelligent Mechatronics, July 2001, Como, Italy.
- [14] Wei Zheng, J. R. Mueller, R. Slovak, & E. Schnieder, "Function modeling and risk analysis of automated level crossing based on national statistical data", Proc. Informatics 2nd in Control, Automation and Robotics (CAR), 2010, International Asia Conference, 2010, 281 – 284.