

An Approach of Control System for Automated Storage and Retrieval System (AS/RS)

M. Soyaslan, A. Fenercioglu, C. Kozkurt

Abstract—Automated storage and retrieval systems (AS/RS) become frequently used systems in warehouses. There has been a transition from human based forklift applications to fast and safe AS/RS applications in firm's warehouse systems. In this study, basic components and automation systems of the AS/RS are examined. Proposed system's automation components and their tasks in the system control algorithm were stated. According to this control algorithm the control system structure was obtained.

Keywords—AS/RS, Automatic Storage and Retrieval System, Warehouse Control System

I. INTRODUCTION

IN today's industry, companies need to improve their competition conditions to survive and provide sustainability.

Automated storage and retrieval systems has an important role in the improvement of these conditions. The control and fastness of production-storage-delivery operations of the firms that make their storage and retrieval operations based on classic human operated forklifts are more difficult. In these systems, the stock data management and human based product storage can cause to various failures and problems. Therefore, storage and retrieval operations of the products that don't depend on human operation provide a lot of advantages. When AS/RS is used instead of the classical systems, there is an important reduction in the aisle areas for forklifts and the system's control can be done easier via the computer database.

When the related studies are examined, it is seen that automation solutions and control structures are offered with various demo workings, and time optimization problems were frequently worked on. Dimitrios Bargiotas *et al.* [1] developed a low cost AS/RS for small and medium size companies. They built a prototype of the system and constructed a demo version of AS/RS. Cai Wenxue and Wu Zhongming [2] used Colored Petri Net (CTPN) for the deadlock study which is a significant problem in most workings about AS/RS. Sunderesh S. Heragu *et al.* [3] modeled the AVS/RS (Autonomous Vehicle Storage and Retrieval System) and used MPA (manufacturing system performance analyzer) to examine the performance of an AVS/RS. They used experimental results to show if the OQN (Open Queueing Network) methodology can be applied to analyze an AVS/RS and determined MPA is a better choice to quickly evaluate alternate configurations of the AVS/RS. Xiao-zhi Liu *et al.* [4] researched current applications of RFID in AS/RS by using Kingview, Visual Basic and MS Access, a control system.

M. Soyaslan is Research Assistant in the Faculty of Engineering and Natural Science, Gaziosmanpasa University, 60150, Tokat, Turkey (phone: +90 356 252 1616 / 2890; e-mail: mucahit.soyaslan@gop.edu.tr).

A. Fenercioglu is Assistant Professor in the Faculty of Engineering and Natural Science, Gaziosmanpasa University, 60150, Tokat, Turkey (e-mail: ahmet.fenercioglu@gop.edu.tr).

C. Kozkurt is Research Assistant in the Faculty of Engineering and Natural Science, Gaziosmanpasa University, 60150, Tokat, Turkey (e-mail: cemil.kozkurt@gop.edu.tr).

Chin-I. Liu *et al.* [5] designed, analyzed, and evaluated four different automated container terminal (ACT) concepts. Min S. Ko *et al.* [6] developed a case study to simulate and verify the PLC program for an automobile panel AS/RS. They suggested a PLC simulation using 3D models and PLC codes, which consists of real automobile manufacturing data. Zhang Xinmin *et al.* [7] established an optimization model based on least time according to AS/RS machine's horizontal and vertical motion to solve the order picking problem of AS/RS. Zheng Aiyun *et al.* [8] proposed a flexible steel tube AS/RS manufacturing system and gave a Petri net model to represent the system's dynamic behavior. Fang He and Kai Guo [9] focused on the study of data transmission of PROFIBUS-DP network system and a simulation model is set up using Simulink/MATLAB. M.M. Rashid *et al.* [10] proposed a new design of an Automated Storage and Retrieval System using wireless communication to improve existing warehouse management system (WMS). They made the communication between PIC controller and computer by wireless technology and the motion of the system is based on three DC motors for each direction of motion X, Y and Z that is controlled by PIC microcontroller. Chang You Zhao *et al.* [11] established the optimization model of goods locations for stackers with solution algorithms to shorten the operation time of storage and to ensure the shelf stabilization. They analyzed that the dispatching method is practical and effective according to their experimental result. Chengxin Yu *et al.* [12] studied about computer vision and robot technology applications in AS/RS. C. Senanayake and S. Veera Ragavan [13] used an optimization method to determine the optimum storage locations for the goods that will use AS/RS. They used fuzzy control system for the purpose of determining the best storage location. In this study, AS/RS's working strategies, sensor, PLC and other control components are analyzed and automation techniques are discussed. System's control structure is explained with detailed algorithms and AS/RS automaiton components' functions are examined.

II. AS/RS WORKING STRATEGIES

After pallets are transferred to the warehouse input station, AS/RS shuttle robot starts to work. The pallets are placed on the rails with shuttle and aisle robot by moving onto the racks. The shuttle robot takes the pallet (the product stack) on and carries it to the transfer points (aisle robot) and rails. The shuttle robot solid model is shown in Fig. 1.

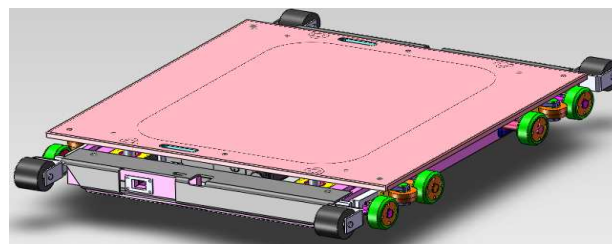

Fig. 1 Shuttle robot solid model

The aisle robot works on two axes as depth and height between the racks, along the aisle and carries the pallet to the assigned tube entry. The assignment of the pallet address is determined according to barcode information and system working algorithm. The aisle robot solid model is shown in Fig. 2.

A. Storage Process of AS/RS

In the warehouse, storage and retrieval processes are considered according to first in first out (FIFO) rule. Storage process starts with shuttle robot movement. Shuttle robot takes the product pallet on and carries it to the desired cell address. All pallets in the rack tubes must belong to same series of product, so the shuttle robot carries the pallets to the deepest cells in the tube and the product data stored in the system PC database. This process is completed after the shuttle leaves the pallet and comes back to input station.

B. Retrieval Process of AS/RS

The retrieval process starts when the empty shuttle is selected by the PC program and transferred to the aisle robot. Then aisle robot carries the shuttle to the assigned tube entry and shuttle robot takes the pallet on and turns back to the aisle robot as loaded. The aisle robot carries the shuttle with pallet to the transfer point. At this point, shuttle robot leaves aisle robot and carries pallet to the output station and comes back to input station as unloaded, so retrieval process is completed.[14]

III. SENSOR TYPES AND POSITIONS

In the AS/RS, there are a lot of sensors on the aisle and shuttle robot. These sensors are connected to the motion control unit and shuttle PLC as input units.

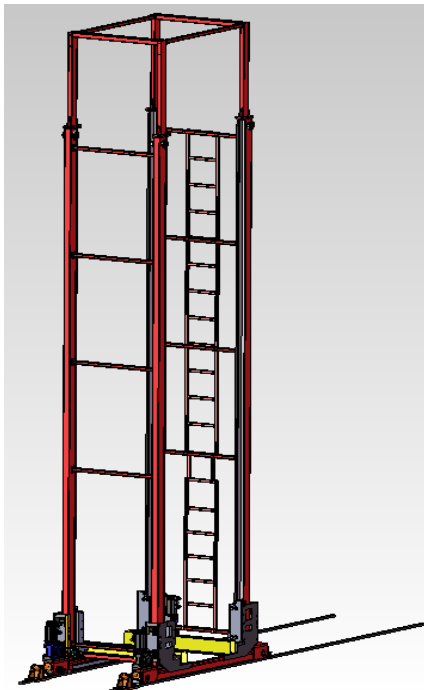

Fig. 2 Aisle robot solid model

Sensor data that is sent to the PC via wireless provides the control of aisle and shuttle robot servo motors according to running control algorithm. The types of the sensors that are used in the system are retro reflective photoelectric sensors, reflective sensors, fork-through-beam sensors and limit switches. On the aisle and shuttle robot, there are wireless access points that communicate with the control units. Thus, shuttle, aisle robot and PC communicate and work as synchronized.

A. Shuttle Robot Sensors and Positions

Shuttle robot has got 7 sensors. The positions of these sensors are designed considering all of the shuttle operations. All of the sensors are connected to shuttle PLC input terminals. Shuttle robot top view and sensors' positions are shown in Fig. 3. The functions of the shuttle robot sensors are examined below. Shuttle Robot Sensor 1 and 2 (srs1 and srs2) are located on the pallets two sides in vertical position. They are retro reflective photoelectric sensors. When the shuttle robot goes to under of the pallet, 2 sensors switch on and it is understood that the pallet is exactly on the shuttle robot. At this position, carrying motor is stopped, lifting motor is started and the pallet is taken on to the shuttle robot. Srs3 and srs4 are retro reflective photoelectric sensors which are located with 45° angle and detect the pallet on the rail. After they detect the pallet's top point, servo motor deceleration ramp function is started. Shuttle slows down and enters under the pallet. When srs1 and srs2 switch on, carrying motor is stopped. Srs5 and srs6 are retro reflective photoelectric sensors which detect the next pallet when shuttle robot comes to desired cell address. The carrying servo motor starts the deceleration ramp function according to srs3 or srs4 signals and stops when the srs5 or srs6 is switched on and the lifting motor starts downward and leaves the pallet to the rack. Srs7 is a reflective sensor that is located in the middle of the shuttle robot and it operates with the aisle robot sensors 1 and 2 (ars1, ars2) together. It detects whether shuttle robot is exactly on the aisle robot or not. When it detects the reflector at the aisle robot it is switched on and this means the shuttle robot is exactly at the aisle robot, so the carrying motor is stopped.

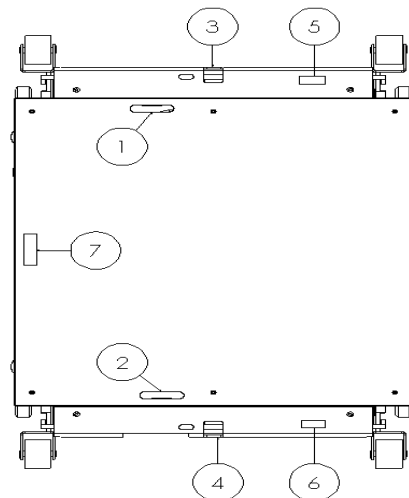

Fig. 3 Shuttle robot sensor positions (top view)

B. Aisle Robot Sensors and Positions

There are totally 11 sensors on the aisle robot. 9 of the sensors are connected to the control unit as an input. 2 of them are limit switches and turn off the system's energy directly for unusual circumstances. The aisle robot top view and sensor positions are shown in Fig. 4. The aisle robot sensors and their functions are examined below.

Aisle Robot Sensor 1 and 2 (ars1 and ars2) are reflective sensors that are located with 10° angle at the two sides of aisle robot. They control if the shuttle robot is exactly on the aisle robot. If both sensors are switched on, shuttle robot with pallet is on the aisle robot. These sensors work synchronously with ars3 and srs7 and shuttle robot is stopped in the middle of the aisle robot.

Ars3 is the reflective sensor that detects if the shuttle robot comes to aisle robot. When the optical sensor on the aisle robot detects the reflector at the shuttle robot, it is switched on, so the shuttle robot is located on the aisle robot and the shuttle carrying motor is stopped.

Ars4, ars5, ars6 and ars7 are fork-through-beam sensors that are located at the each column of the aisle robot. They are placed in the same level at the columns and determine the shuttle robot's position by measuring the vertical height like encoders. The reason of locating at each column is to balance the mechanical or ground differences and smooth transition of shuttle robot to tube.

Ars8 is a reflective sensor that detects if a pallet comes to the input station. The sensor's reflector is located 10 meter away from aisle robot and when a pallet comes to the input station the sensor switches on. Then shuttle robot is sent to the pallet.

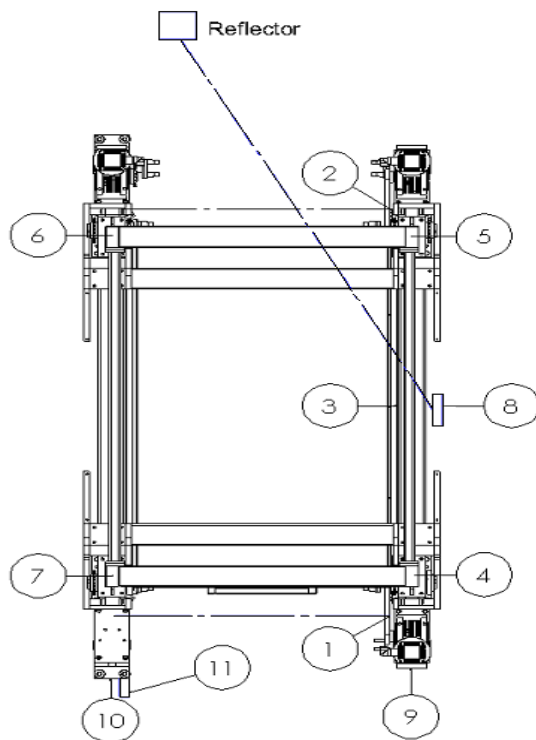

Fig. 4 Aisle robot and sensor positions (top view)

Ars9 and ars10 are mechanical limit switches that are located at the two sides of aisle robot. They prevent passing the boundaries of the aisle robot. When the aisle robot comes to the end of the line, the system is powered off directly. Limit switches are not connected to the control unit.

Ars11 is a fork-through-beam sensor that is used to arrange the location differences caused by system's mechanical position losses. The position data that is received from the motor encoder is confirmed by this sensor. It detects the metal parts that are located in the rail certain distances and determines the aisle robot position.

IV. CONTROL UNITS

Control structure of the system has 3 control components. These are Motion Control Unit that is located on the aisle robot, the PLC that is placed on the shuttle robot and PC system which communicates with motion control unit and PLC. In the running program, the barcode information is queried and according to product's various priorities the pallet addresses are determined. Then commands are sent to the shuttle PLC and aisle robot motion control unit with wireless access points.

A. Shuttle Robot Control Algorithm and Operational Period

Robot operations are determined according to sensors' data and designed algorithm. The sensors and motor operational periods start with shuttle robot's empty position on the aisle robot and continue with taking pallet on from input station and coming and getting on to the aisle robot. It is shown in Fig. 5. When ars8 detects the pallet on the rail, shuttle carrying motor (SCM) is started. When the shuttle robot comes closer to the pallet, srs3 or srs4 (according to direction) detects the pallet's top point and the deceleration ramp function command is sent to SCM driver by shuttle PLC. SCM is stopped when shuttle robot comes to under the pallet and srs1, srs2 is switched on respectively. Then shuttle robot lifting motor (SLM) is started and lifts the pallet 4 cm so the pallet is taken from rail to shuttle robot. SCM is started again and loaded shuttle is taken to aisle robot. As soon as the shuttle robot comes to aisle robot, SCM is stopped with the switched on respectively ars2, ars1, ars3 and srs7. Top view of shuttle robot is shown in Fig. 6 and schematic diagram of the shuttle robot is shown in Fig. 7.

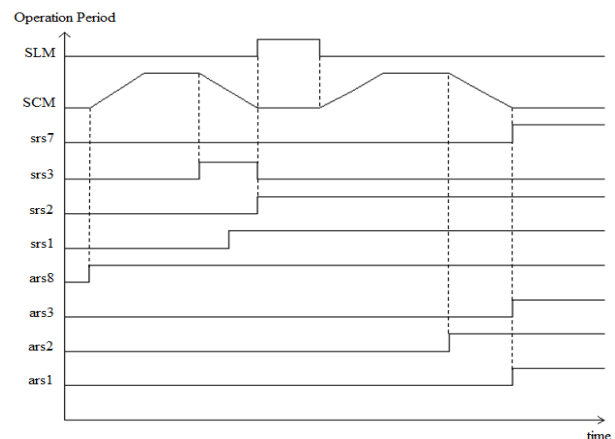

Fig. 5 Shuttle robot operation period graph

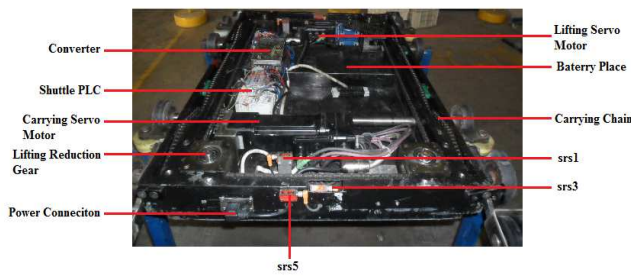

Fig. 6 Top view of the shuttle robot

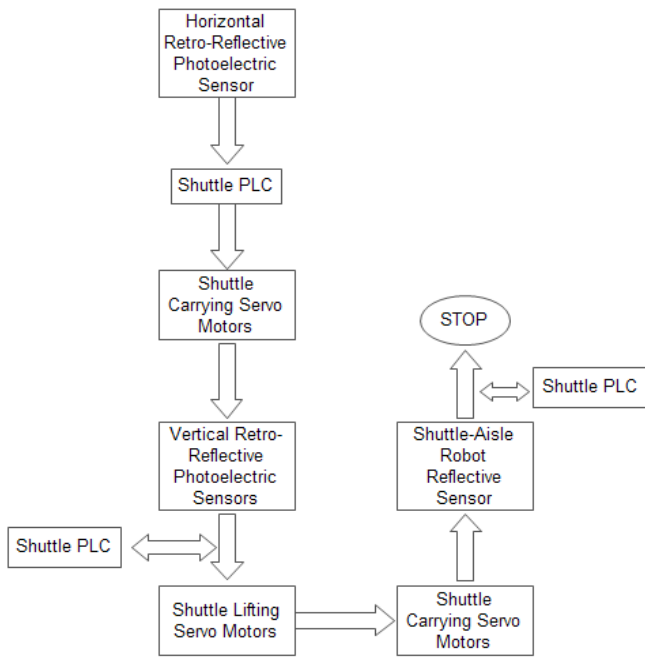

Fig. 7 Shuttle robot schematic diagram

B. Aisle Robot Control Algorithm

Aisle robot starts to carry the loaded shuttle in two axes according to the assigned cell address which is determined by PC algorithm. The operational graph of the motors and sensors is shown in Fig.8. It is included that shuttle robot gets on to aisle robot and carry it to the 4. row, 3. floor tube entry.

Aisle robot carrying motor and lifting motor (ACM and ALM) start after ars2, ars1, ars3 and srs7 are switched on respectively. Ars4, ars5, ars6 and ars7 keep the vertical position data equal and are switched on 3 times during the lifting operation because of 3. floor. Ars11 is used as a position verifying sensor to control the horizontal distance of the aisle robot and switched on 4 times because of 4. row. The encoder position data is used to transfer the shuttle robot at the tube level. When the aisle robot come to tube entry ACM and ALM is stopped. Then SLM starts and lifts the pallet and with SCM operation, shuttle robot takes the pallet to the deepest cell address. SCM is stopped when srs5 or srs6 is switched on, so the pallet is being carried to the assigned cell address. Aisle robot schematic diagram is shown in Fig. 9.

The motion control unit that is located on the aisle robot is used frequently in the industry for controlling servo motors. It supports many communication protocols such as Ethernet FINS, TELNET, DeviceNet, ProfiBus, Serial (RS232 & RS485), ModbusTCP and CANOpen.

The motion control unit Trajeixa [15] that is used in the system controls 6 servo motors via Mechatrolink-II motion network. The aisle robot control panel is shown in Fig. 10.

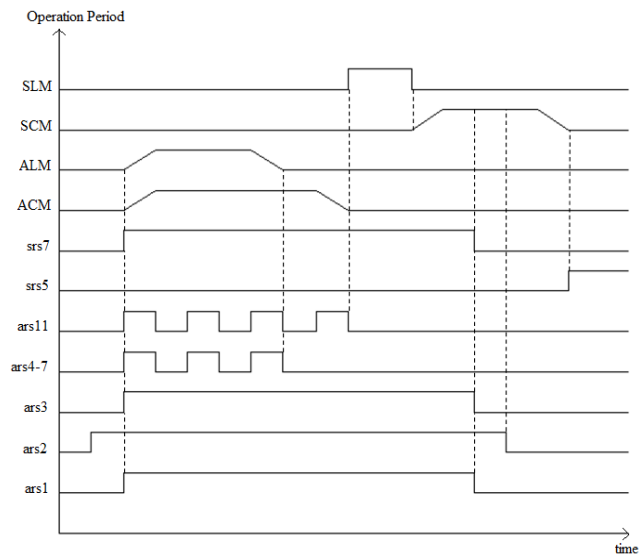

Fig. 8 Aisle robot operation period graph

Shuttle and aisle robot vertical and horizontal velocities are assumed 0.5 m/s and acceleration and deceleration ramp function periods are 2 s.

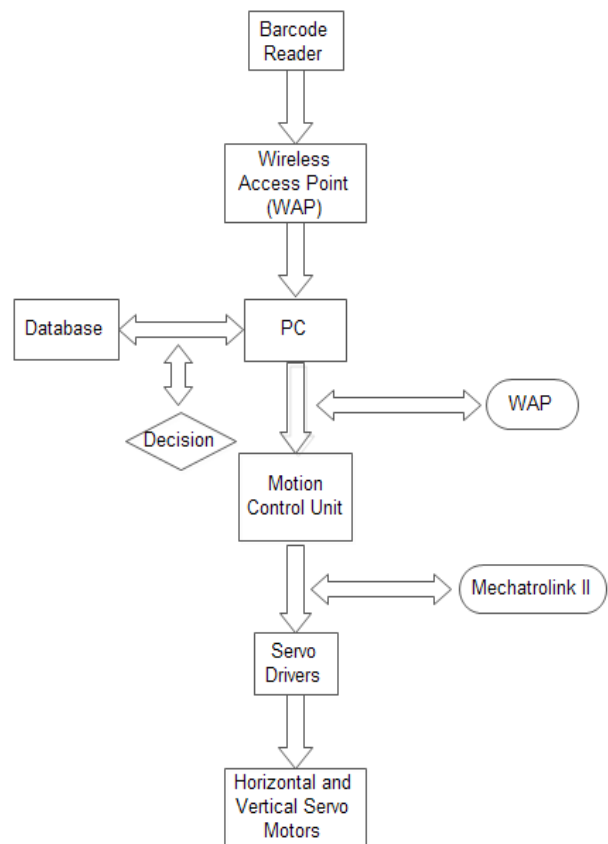

Fig. 9 Aisle robot schematic diagram

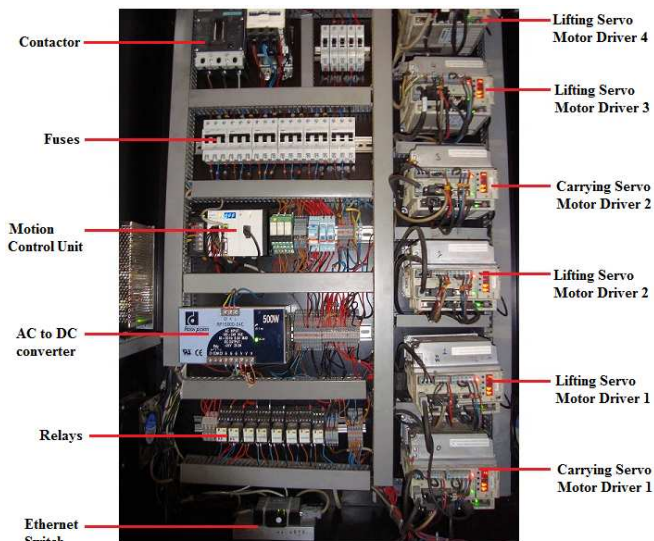

Fig. 10 Aisle Robot Control Panel

V. CONCLUSION

In the presented study, robots and control components and sensors of AS/RS are described. AS/RS consists of shuttle and aisle robot. Aisle robot works on two axes between warehouse racks. Shuttle carries the product pallets on the single axis rail. Shuttle robot is a split platform but aisle robot coordinates with it for storage and retrieval process.

The system storage and retrieval algorithm and operation periods of robots for assigned task are discussed. The aisle and shuttle robot actuators, controllers, sensors and their functions are detailed. Operation timing diagrams of robots are shown.

This study consists of AS/RS control algorithms and components and it can be an important reference at this area.

ACKNOWLEDGMENT

This study is a work of the project which is cooperated with DIMES and Gaziosmanpasa University. The project is supported by Republic of Turkey, Ministry of Science, Industry and Technology and DIMES Corporation (SAN-TEZ Project No: 00889.STZ.2011-1). It is not official view of the Ministry.

REFERENCES

- [1] Dimitrios Bargiotas, Aphrodite Ktena, Christos Manasis and Onoufrios Ladoukakis, "A scalable low-cost automated storage & retrieval system," in *16th International Conference on Systems, Signals and Image Processing, 2009*, Greece, pp. 1-4.
- [2] Cai Wenxue, Wu Zhongming, "An Approach to Model the AS/RS via Colored Timed Petri Net," in *International Conference on Logistics Systems and Intelligent Management, 2010*, China, pp. 590-594.
- [3] Sunderesh S. Heragu, Xiao Cai, Ananth Krishnamurthy, Charles J. Malmberg, "An Approach to Model the AS/RS via Colored Timed Petri Net," in *5th Annual IEEE Conference on Automation Science and Engineering, 2009*, Bangalore, India, pp. 455-459.
- [4] Xiao-zhi Liu, Su-mei Xiao, Shan Cai, Zhao-long Xu, "Design of Control System for Automated Storage and Retrieval System Based on RFID and Kingview," in *International Conference on E-Product E-Service and E-Entertainment, 2010*, Henan, China, pp. 1-3.
- [5] Chin-I. Liu, Hossein Jula, and Petros A. Ioannou, "Design, Simulation, and Evaluation of Automated Container Terminals," in *IEEE Transactions On Intelligent Transportation Systems*, vol. 3, no. 1, pp. 12-26, March 2002.

- [6] Min S. Ko, G.N. Wang, Hye S. Shin, Sang C. Park, "Machine Control Level Simulation Of An AS/RS In The Automotive Industry," in *Winter Simulation Conference, 2010*, Phoenix, Arizona, pp. 1727-1738.
- [7] Zhang Xinmin, Kong Xiangzhuo and Han Xiaoguang, "Modeling and Optimizing Fixed Shelf Order-Picking for AS/RS Based on Least Time," in *IEEE International Conference on Automation and Logistics, 2008*, Qingdao, China, pp. 748-752.
- [8] Zheng Aiyun, Liu Weimin, Lu Chunguang, Wang hui, Song Chuanping, "Modeling and Optimizing Research for the Steel Tube AS/RS System," in *Control and Decision Conference (CCDC), 2011*, China, pp. 3979-3983.
- [9] Fang He and Kai Guo, "Modeling and Simulation of PROFIBUS-DP Network Control System," in *International Conference on Automation and Logistics, 2008*, Qingdao, China, pp. 1141-1146.
- [10] M.M. Rashid, Banna Kasemi, Mahmudur Rahman, "New Automated Storage and Retrieval System (ASRS) using wireless communications," in *4th International Conference on Mechatronics (ICOM), 2011*, Kuala Lumpur, Malaysia, pp. 1-7.
- [11] Chang You Zhao, Yun Yang and Jian Feng Li, "Research on Goods Locations Distributing Optimization for Tobacco AS/RS," in *IEEE International Conference on Automation and Logistics, 2007*, Jinan, China, pp. 553-556.
- [12] Chengxin Yu, Li Zhao, Na Xu, Shaolin Li, Yunchang Gao, Shuili Ju, "Study of Computer Vision and Robot Control Technology in AS/RS," in *IEEE International Conference on Automation and Logistics, 2007*, Jinan, China, pp. 876-879.
- [13] C. Senanayake and S. Veera Ragavan, "A Fuzzy Implementation for Optimization of Storage Locations in an Industrial AS/RS," in *World Academy of Science, Engineering and Technology*, vol. 39, pp. 38-43, 2008.
- [14] A. Fenercioglu, M. Soyaslan, C. Kozkurt, "Automatic Storage And Retrieval System (AS/RS) Based On Cartesian Robot For Liquid Food Industry," in *12th International Workshop on Research and Education in Mechatronics, September 2011*, Kocaeli, Turkey, pp. 283-287.
- [15] OMRON EUROPE B.V, *Trajexia Motion Control System Manual*, Cat. No. I52E-EN-05, 2010, Netherland.