

# Web-Based Control & Notification for Home Automation Alarm Systems

Helder Adão, Rui Antunes, and Frederico Grilo

**Abstract**—This paper describes the project and development of a very low-cost and small electronic prototype, especially designed for monitoring and controlling existing home automation alarm systems (intruder, smoke, gas, flood, etc.), via TCP/IP, with a typical web browser. Its use will allow home owners to be immediately alerted and aware when an alarm event occurs, and being also able to interact with their home automation alarm system, disarming, arming and watching event alerts, with a personal wireless Wi-Fi PDA or smartphone logged on to a dedicated predefined web page, and using also a PC or Laptop.

**Keywords**—Alarm Systems, Home Automation, Web-Server, TCP/IP.

## I. INTRODUCTION

THERE are nowadays in the market many different types of home automation systems. Although several popular integrated systems like X10, EIB (European Installation Bus), Echelon Lonworks, and National Instruments LabVIEW modules, already bring along the possibility to add internet servers for distance remote web monitoring/control and for alarm notification, these are yet still quite expensive and are not usually full compatible with previous home automation models.

The main goal for this project was to build a very low-cost electronic prototype, with the use of an embedded standard micro web-server, with built-in IP connectivity, to allow receiving and sending digital commands, via TCP/IP [1], for all existing alarm and notification home automation models, and without the need to have a dedicated server PC or even special software.

## II. HARDWARE IMPLEMENTATION

### A. The Micro Web-Server

The low-cost Modtronix SBC45EC board [2] was used to implement the micro web-server. It contains a PIC18F452 microcontroller [3] and a 24LC1025 non-volatile EEPROM

Manuscript received December 31, 2007. This work was supported by Escola Superior de Tecnologia de Setúbal (ESTSetúbal), Portugal.

Helder Adão is a final year BSc Electronics and Computers Student at Escola Superior de Tecnologia de Setúbal, Professor Rui Antunes and Assistant Frederico Grilo are with the Electrical Engineering Department at Escola Superior de Tecnologia de Setúbal (Setúbal Polytechnic Institute), Rua Vale de Chaves, Estefanilha, 2910-761 Setúbal, Portugal (phone: 351-265-790000; fax: 351-265-721869; e-mail: rui.antunes@estsetubal.ips.pt , fgrilo@est.ips.pt).

that can store up to 128Kbyte of data (net configuration, username and password for login, I/O values, and for the web pages that will be loaded and presented [4]).



Fig. 1 Modtronix SBC45EC board

It has also an Ethernet 10BaseT interface, allowing the connection to an Ethernet line.

Sample source code for programming is also available at the web site: <http://www.modtronix.com/products/sbc45ec/>.

### B. An Implementation for Intruder Alarm Systems

It was used a DSC PowerSeries [5] intruder alarm control panel to test the web-control module for alarm monitoring, notification and control. The basic electrical signals used are:

TABLE I  
ELECTRICAL SIGNALS OF AN INTRUDER ALARM SYSTEM

Signal	Function	Source	Enabled
BELL	sounder bell	output	+12V $\downarrow$ 0V
STR	sounder strobe	output	+12V $\downarrow$ 0V
VBAT	power (+12V)	power	All
GND	ground (0V)	power	All
TR	sounder tamper return	input	0V $\rightarrow$ Open

The BELL signal is an output from the alarm control panel. It is used for triggering sounder devices. The STROBE signal is another output from the alarm control panel that will enable the flash lamps from the external sounder. VBAT and GND are the power source terminals for the alarm control and the external sounder. Power is +12V. TR (“Tamper Return”) input is the external sounder output signal, and it is used to inform of an opened sounder cover tamper condition.

In all hardwired commercial alarm systems each protected zone is made with a closed loop circuit, where a fixed controlled current flows [6]. The first protected zones are usually door entry zones, for manual or remote entry and exit pre-time arming and disarming. Several intruder alarm configurations are available. Usually are called NC, NO, EOLR, DEOLR (or 2-EOLR), and 3-EOLR loop circuits.

End-of-Line-Resistors (EOL) are very important because they can supervise the wires, preventing wire tampering. If someone shorts the loop wires, it will hide the EOL resistor from the control panel, thus letting the control panel know. S1, S2 and S3 are usually normally closed (NC) intrusion detectors, and, when detecting intrusion (or a broken wire), will open, causing the zone current loop (Iloop) to become null, triggering the alarm sounder.

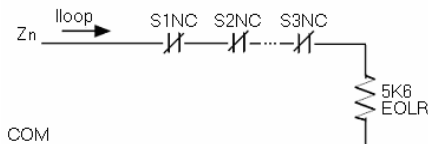

Fig. 2 Typical EOLR NC nth zone alarm circuit hardwired configuration

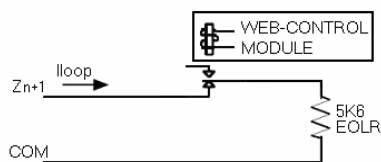

Fig. 3 Dedicated EOLR NC n+1th maintained key switch arm zone, with web-control module

To arm and disarm the alarm control panel we must previously program the last zone exclusively for these propose. Zones may be programmed to be used as key switch arming/disarming zones. The key switch web-control module has to be connected to the loop zone programmed as maintained key switch arm. In the restored state, the panel is always disarmed. The switching of this n+1th zone to the alarm state will make the control panel to arm.

For detecting alarm events, the web-control module must be able to monitor the control panel BELL output terminal. An optional output line (PGM1) may also be programmed, when possible, to confirm the armed condition. The BELL output may also usually need an external 1KΩ pull-up resistor (Rp) to work properly, depending on the control panel and the sounder models. The complete intruder alarm circuit diagram is presented in Fig. 4:

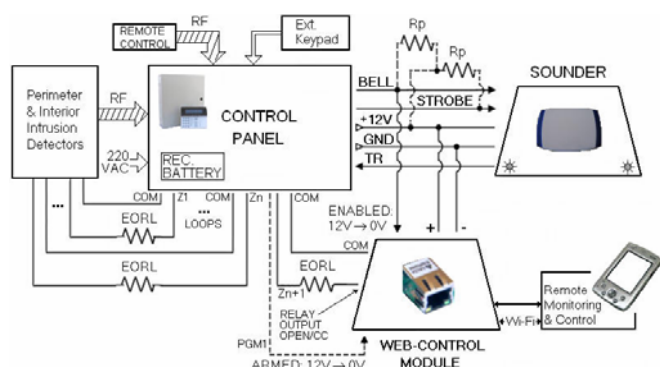

Fig. 4 Complete DSC alarm circuit for web-control and monitoring

### C. The I/Os Circuit

The I/Os circuit allows three independent electrically isolated inputs and three independent NC relay outputs. Optocouplers were used to electrically isolate the three BELL inputs (for three different control panels). Normally closed diode protected output relays were used to connect to the maintained key switch arm zones (Zn+1), for arming and disarming up to three alarm control panels. The input resistor values for the optocouplers can be settled for +5V, +12V (BELL) or +24V input signals. So the I/Os circuit can easily be suited to detect and notify other types of home automation alarm signals, such as smoke, gas, flood, rain, water pump installation, irrigation, heating, swimming pool alarms, wastewater problems, etc.

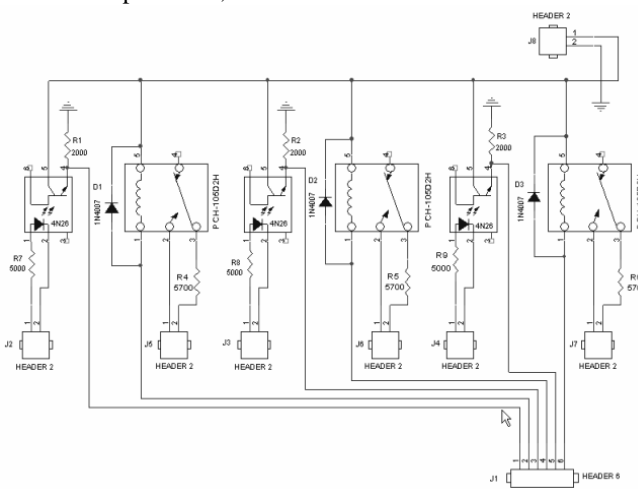

Fig. 5 I/Os circuit for arming/disarming, and alarm trigger monitoring



Fig. 6 Alarm system and external keypad connected to the working I/Os circuit and the micro web-server board

### III. BUILDING ON-DEMAND WEB-CONTROL PAGES

The web-server controller allows the interaction with .CGI extension (Common Gateway Interface) web pages, for calling pre-defined functions within the web-server from any

internet browser. We can use predefined commands and parameters in the source code of the web pages, JavaScript and html commands, to be replaced by variable values. With these, we can read input values and set or reset outputs directly from a web page, using a web browser.

One might consider using the Opera browser (mobile [7], mini [8] or standard), allowing several web pages to be simultaneously presented (each one dedicated for each alarm control panel), or also, for example, the Mozilla Firefox browser.

Dreamweaver 8 and Notepad++ software application tools where used for developing the web pages and for editing the JavaScript language. Aptana [9], a new JavaScript compiler, might also be used.

#### A. The FTP Web Page Download Process

To successfully download a web page into the micro web-server non-volatile 24LC1025 EEPROM, we need first to convert all the CGI source files stored at a work directory into a correspondent binary file. The "doall" batch file calls the "mpfs" converter to create a default.bin file that will be downloaded, via FTP, to the Modtronix SBC45EC micro web-server.

Note that if we are in a local area network (LAN), we need first to configure the internet protocol (TCP/IP) properties (on the right window above), for direct FTP programming to the micro web-server:

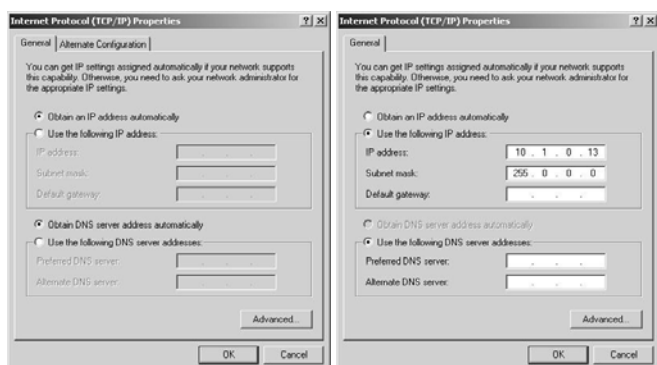

Fig. 7 Internet protocol (TCP/IP) properties configuration (for www access and for FTP web-server programming)

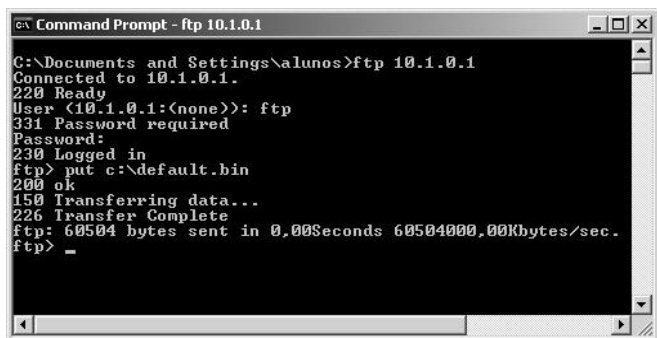

Fig. 8 FTP commands for programming the micro web-server with the default.bin file

Up to 128Kbyte of data can be stored into the micro web-server, including the possibility to even put compressed JPEG images and WAV sound files into the developed web pages.

#### B. Software Interface Application

The software interface application is actually a dynamic web page, with six menus (http://10.1.0.1/menu.htm), now opened with Mozilla Firefox (or even any other browser).

For security, a username and a password will be automatically prompted to the visitor when he first tries to access this web page. Predefined string values for the username and password are stored in the source file.

In this example, the web page will immediately inform the user when an alarm sounder event triggers, also allowing him anytime to remotely disarm or arm the control panel. With a PDA or a smartphone logged on to a dedicated predefined web page, the homeowner user will remotely listen an alarm sound (from a predefined WAV file) when the BELL output voltage changes from 12V to 0V, meaning that the sounder has fired.

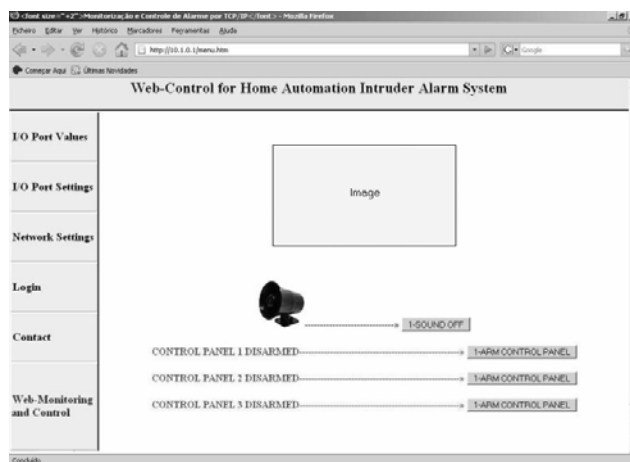

Fig. 9 Web-control for a home automation alarm system

The I/O Port Values menu allows an authorized user to monitor and set the several PIC18F452 digital I/O port pins:

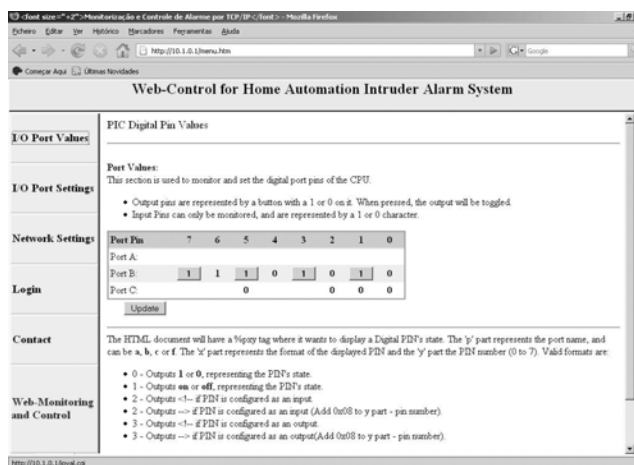

Fig. 10 I/O port values monitoring and setting

The I/O Port Settings menu allows the user to settle the direction of the I/O PIC pins (as an input or an output), as shown in Fig. 11:

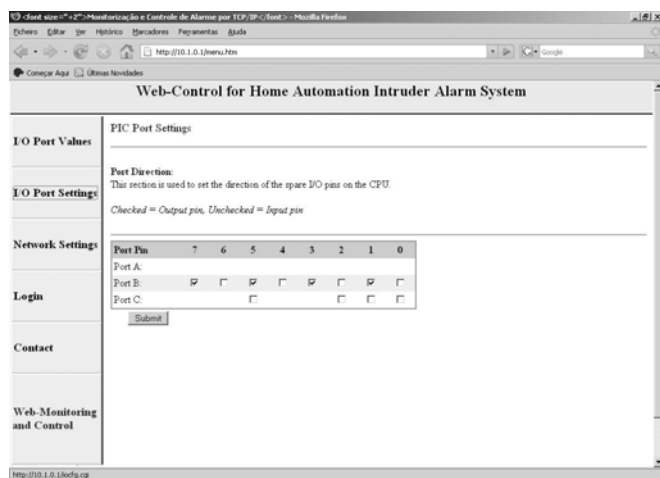

Fig. 11 Setting the direction of the I/Os used

The net settings of the micro web-server (IP, Subnet mask, Gateway and MAC address) can also be changed in the Network Settings menu:

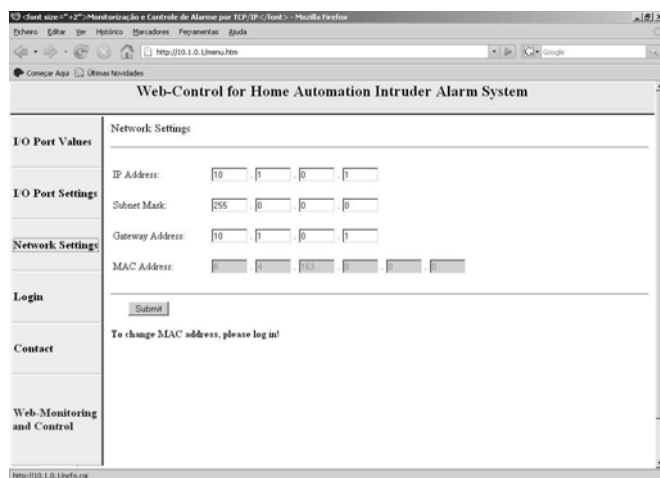

Fig. 12 Changing TCP/IP settings

### C. Html and JavaScript Code

The main code shown below can deal with up to three different control panel alarm systems, and defines six variables for the three input and three output signals, assuming that control panel programmable output arming detection is unavailable.

```
<html>
<body>
<form method=GET action=monitc.cgi>
<div align="center">
<script type="text/javascript">
```

```
/*alarm1 monitoring and control variables:
g: control panel 1 input BELL signal
h: control panel 1 output disarm/arm control relay signal */
var g=%b00;
var h=%b01;
```

```
/*alarm2 monitoring and control variables
i: control panel 2 input BELL signal
j: control panel 2 output disarm/arm control relay signal */
var i=%b02;
var j=%b03;
```

```
/*alarm3 monitoring and control variables
k: control panel 3 input BELL signal
l: control panel 3 output disarm/arm control relay signal */
var k=%b04;
var l=%b05;
/*sound on/off flag*/
var flg=%b07;
```

The code for disarming the control panel 1 is:

```
/*when B1=1 control panel 1 is disarmed*/
if (h= =0)
document.write('<h4 align=center><font
color=#FF0000>CONTROL PANEL 1 DISARMED-----
----->>%b21
<input name="B1" type="submit" value="%b01-ARM
CONTROL PANEL"
%b29 %b31 %b01 %b39</h4>');
```

And below is the code for now arming the control panel 1:

```
/*when B1=0 control panel 1 is armed*/
if (h= =1 &&g!=0)
document.write('<h4 align=center><font
color=#009999>CONTROL PANEL 1 ARMED-----
----->>%b21
<input name="B1" type="submit" value="%b01-DISARM
CONTROL PANEL"
%b29 %b31 %b01 %b39</h4>');
```

When the BELL signal from the control panel 1 switches from +12V to 0V, the alarm 1 is fired and the web page will auto execute the sirene.wav sound file (if the sound flag is on):

```
/*Alarm 1 fired, with the sound option flag on*/
if(h= =1&&g= =0&&flg= =1)
{
document.write('<embed src="sirene.wav" width="0"
height="0"></embed>');
document.write('<h4 align=center><font
color=#009999>CONTROL PANEL 1 ARMED-----
>><font color=#FF0000>ALARM FIRED----->>%b21
<input name="B1" type="submit" value="%b01-DISARM
CONTROL PANEL"
%b29 %b31 %b01 %b39</h4>');
}
```

If the sound flag is off, the web page will not auto execute the

sirene.wav sound file, and will remain silent, yet with the "alarm fired" warning message still visible:

```
/*Alarm 1 fired, with the sound option flag off*/  
if (h= =1&&g= =0&&flg= =0)  
{  
document.write('<h4 align=center><font  
color=#009999>CONTROL PANEL 1 ARMED-----  
><font color=#FF0000>ALARM FIRED----->%b21  
<input name="B1" type="submit" value="%b01-DISARM  
CONTROL PANEL"  
%b29 %b31 %b01 %b39</h4>');  
}  
}
```

#### IV. EXPERIMENTAL TESTS

Complete alarm system web-tests were made at the Lab with the aid of its local area network, and the system is working perfectly. Care should be taken in this case, in order to distinguish from the PC local IP address and the micro web-server local IP address. For example, if we configure the micro web-server IP as: 10.1.0.1 and with 255.0.0.0 as the Subnet mask, we must put for the PC configure internet protocol (TCP/IP) properties menu the last number different from 1, ranging from 2 to 255 (for example: 10.1.0.13).



Fig. 13 Alarm system web tests at Lab (using a PC)

#### V. CONCLUSION

This project proves that it is possible to obtain an extremely low-cost alarm system control and monitoring solution for homeowners. A highly adapted and versatile CGI html and JavaScript web page can be built, even by the user itself, to support an existing old or new home automation alarm system (such as an intruder alarm control panel, or any other), along with a personalized created web page being directly downloaded into a small non-volatile device.

There is no need for having a dedicated server PC maintaining the web-page, nor even the need for special software. With a common browser it is possible to use a

PC/Laptop, a small PDA or a smartphone and to, at a regular cost, remotely control many home (and other) alarm systems.

For future work, we intend to develop the alarm file event logging, and also to automatically send alarm notifying e-mails.

#### ACKNOWLEDGMENT

We wish to acknowledge the Department of Electrical Engineering at Escola Superior de Tecnologia de Setúbal/IPS for the Lab conditions and resources.

#### REFERENCES

- [1] Z-World Inc, 2001. "An Introduction to TCP/IP for Embedded System Designers".
- [2] "Modtronix SBC45EC". Available: <http://www.Modtronix.com>
- [3] "PIC18F452 Datasheet". Available: <http://www.microchip.com>
- [4] "AN833- The Microchip TCP/IP Stack Application Note". Available: <http://www.microchip.com>
- [5] "DSC PowerSeries". Available: <http://www.dsc.com/Home.aspx>
- [6] R. Antunes, "Manual do Curso de Formação de Projecto e Instalação de Sistemas de Alarme", ESTSetúbal, 2007.
- [7] <http://www.opera.com/products/mobile/>
- [8] <http://www.operamini.com/>
- [9] <http://www.apтана.com/>



**Helder Adão** was born in Lisbon, in 1976. He is currently a final year BSc electronics and computers Student at Escola Superior de Tecnologia de Setúbal, in the Setúbal Polytechnic Institute (Portugal).

Helder Adão actual research interests involve analog and digital electronics, microcontrollers and home automation systems.



**Rui Antunes** was born in Lisbon, in 1970. He received the degree in electronic and computer engineering from the Technical University of Lisbon, Instituto Superior Técnico (IST), Portugal, in 1993, and the MSc degree in electronic and computer engineering, in 1999, from the Technical University of Lisbon, Instituto Superior Técnico (IST), Portugal. Currently he is working towards his Ph.D. degree in Electrical Engineering at Faculdade de Ciências e Tecnologia - New University of Lisbon

(FCT-UNL), Portugal.

He has worked at Ford Electronics (Palmela), and he is currently Adjunct Teacher with the Electrical Engineering Department at Escola Superior de Tecnologia de Setúbal, in the Setúbal Polytechnic Institute (Portugal).



**Frederico Grilo** was born in Estremoz, in 1969. He received the degree in electronic and computer engineering from the Technical University of Lisbon, Instituto Superior Técnico (IST), Portugal, in 1995. Currently he is working towards his Ph.D. degree in Electrical Engineering at Évora University, Portugal.

He has worked at Siemens (Évora), and he is currently Assistant with the Electrical Engineering Department at Escola Superior de Tecnologia de Setúbal, in the Setúbal Polytechnic Institute (Portugal), and also Mechatronics Engineering Assistant at Physics Department in Évora University (Portugal).