

# The Comparison Study of Current Control Techniques for Active Power Filters

T. Narongrit, K-L. Areerak\* and K-N. Areerak

**Abstract**—This paper presents the comparison study of current control techniques for shunt active power filter. The hysteresis current control, the delta modulation control and the carrier-based PWM control are considered in the paper. The synchronous detection method is used to calculate the reference currents for shunt active power filter. The simulation results show that the carrier-based PWM control technique provides the minimum %THD value of the source currents compared with other comparable techniques after compensation. However, the %THD values of all three techniques can follow the IEEE std.519-1992.

**Keywords**—hysteresis current control, delta modulation current control, pulse width modulation control, shunt active power filter, synchronous detection.

## I. INTRODUCTION

**P**OWER connected nonlinear loads can generate the harmonics into the systems. These harmonics cause a lot of disadvantages such as loss in transmission lines and electric

devices, protective device failures, and short-life electronic equipments in the system [1]. Therefore, it is very important to reduce or eliminate the harmonics in the system. It is well known that the harmonic elimination via a shunt active power filter (SAPF) [2] as shown in Fig.1 provides higher efficiency and more flexible compared with a passive power filter. In Fig.1, the three-phase bridge rectifier feeding resistive and inductive loads ( $R=130\ \Omega$  and  $L=4\ H$ ) behaves as a nonlinear load into the power systems. A synchronous detection (SD) method [3] is used for a harmonic detection to calculate the reference currents for the shunt active power filter. The hysteresis current control (HCC) [4], [5], the delta modulation control (DMC) [6], [7] and the carrier-based PWM control (CPWM) [8], [9] are considered for performance comparison. The performance index for this comparison is %THD of the source currents after compensation.

The paper is structured as follows. The overview of the synchronous detection method is addressed in Section II.

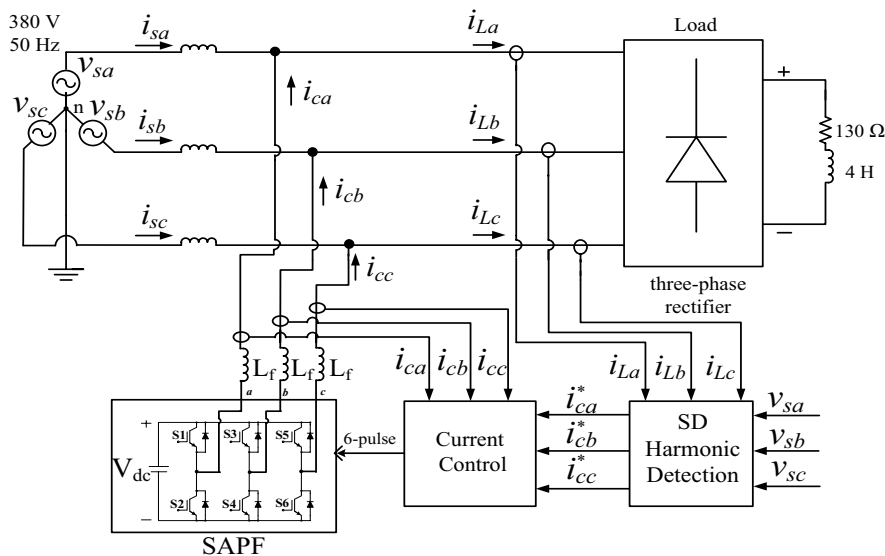

Fig.1 The power system considered

T. Narongrit, Ph.D. student, School of Electrical Engineering, Suranaree University of Technology, Nakhon Ratchasima, 30000, THAILAND.

\*K-L. Areerak, Assistant Professor, PQRU Research unit, PeMC research group, School of Electrical Engineering, Suranaree University of Technology Nakhon Ratchasima, 30000, THAILAND (corresponding author: kongpol@sut.ac.th).

K-N. Areerak, lecturer, PeMC research group, School of Electrical Engineering, Suranaree University of Technology Nakhon Ratchasima, 30000, THAILAND.

The concepts of three current control techniques are presented in Section III. The simulation results and discussion are presented in Section IV. Finally, Section V concludes the results from the comparison study.

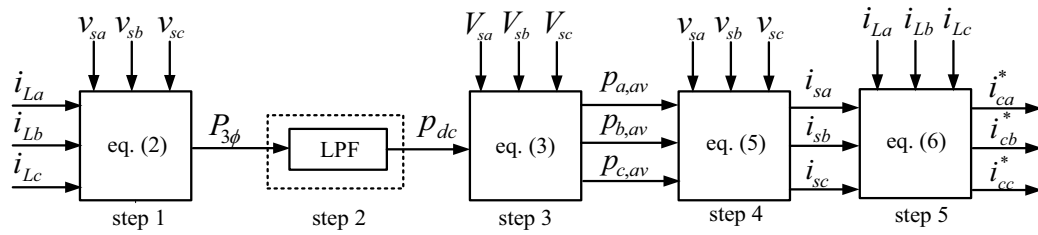

Fig. 2 The block diagram of the synchronous detection calculation

## II. THE HARMONIC DETECTION USING SYNCHRONOUS DETECTION METHOD

The synchronous detection method to calculate the reference currents of shunt active power filter is explained in this section. The assumption of this method is that the balanced three-phase source currents have to be obtained after compensation. Therefore, the peak value of source currents ( $I_{sa}$ ,  $I_{sb}$  and  $I_{sc}$ ) can be set in (1).

$$I_{sa} = I_{sb} = I_{sc} \quad (1)$$

The procedure to calculate the reference currents using the synchronous detection method can be summarized as follows:

*Step 1:* Calculate the three-phase power ( $P_{3\phi}$ ) by:

$$P_{3\phi} = v_{sa}i_{La} + v_{sb}i_{Lb} + v_{sc}i_{Lc} \quad (2)$$

*Step 2:* Determine the fundamental power of  $P_{3\phi}$  ( $P_{dc}$ ) by using low pass filter (LPF) as shown in Fig. 3.



Fig. 3 The separation of the fundamental power from the three-phase power using LPF

*Step 3:* Calculate the average active power for each phase ( $P_{a,av}$ ,  $P_{b,av}$ ,  $P_{c,av}$ ) by:

$$P_{k,av} = P_{dc}V_{sk}/V_{tot} \quad ; k = a, b, c \quad (3)$$

The  $V_{sa}$ ,  $V_{sb}$  and  $V_{sc}$  in (3) are the peak value of three-phase source voltages in phase  $a$ ,  $b$  and  $c$ , respectively. The total of peak voltage ( $V_{tot}$ ) in (3) can be calculated by (4).

$$V_{tot} = V_{sa} + V_{sb} + V_{sc} \quad (4)$$

*Step 4:* Calculate the fundamental source currents for each phase ( $i_{sa}$ ,  $i_{sb}$ ,  $i_{sc}$ ) by:

$$i_{sk} = 2v_{sk}P_{k,av}/V_{sk}^2 \quad ; k = a, b, c \quad (5)$$

where  $v_{sa}$ ,  $v_{sb}$  and  $v_{sc}$  are instantaneous source voltages in phase  $a$ ,  $b$  and  $c$ , respectively.

*Step 5:* Calculate the reference currents of shunt active power filter in each phase ( $i_{ca}^*$ ,  $i_{cb}^*$ ,  $i_{cc}^*$ ) by:

$$i_{ck}^* = i_{Lk} - i_{sk} \quad ; k = a, b, c \quad (6)$$

The block diagram of overall procedure to calculate the reference currents using the synchronous detection method is given in Fig. 2.

## III. CURRENT CONTROL TECHNIQUES

### A. Hysteresis Current Control

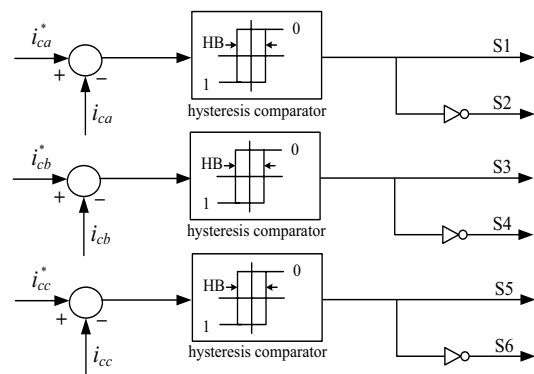

Fig. 4 The block diagram of the hysteresis current control

The hysteresis current control (HCC) scheme is based on a nonlinear control as shown in Fig. 4. The compensating currents ( $i_{ca}$ ,  $i_{cb}$ ,  $i_{cc}$ ) in Fig. 4 are compared with the reference currents ( $i_{ca}^*$ ,  $i_{cb}^*$ ,  $i_{cc}^*$ ) by using hysteresis comparators to

generate the six switching pulses. These pulses are used to control the IGBTs to turn on and turn off. The basic concept of the hysteresis current control is shown in Fig.5. According to Fig.5, hysteresis band (HB) is the possible boundary of the compensating current. This current swings between upper and lower hysteresis limits. For example in phase *a*, if  $i_{ca}$  is equal or over than the upper hysteresis limit ( $i_{ca}^* + HB/2$ ) then the comparator output is 0 (S1=0, S2=1). On the other hand, if  $i_{ca}$  is equal or less than the lower hysteresis limit ( $i_{ca}^* - HB/2$ ) then the comparator output is 1 (S1=1, S2=0). From this operating, the  $i_{ca}$  can swing inside the hysteresis band following the reference current ( $i_{ca}^*$ ). This reference current can be calculated by the synchronous detection method from section II.

The maximum switching frequency ( $f_{s,max}$ ) of IGBTs can be calculated by (7) [10]. The  $V_{dc}$  and  $L_f$  in (7) are the value of the dc bus voltage and the size of inductor, respectively.

$$f_{s,max} = 2V_{dc}/9HBL_f \quad (7)$$

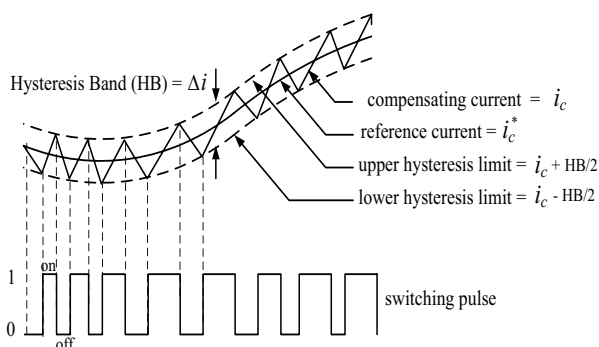

Fig. 5 The basic concept of the hysteresis current control

### B. Delta Modulation Current Control

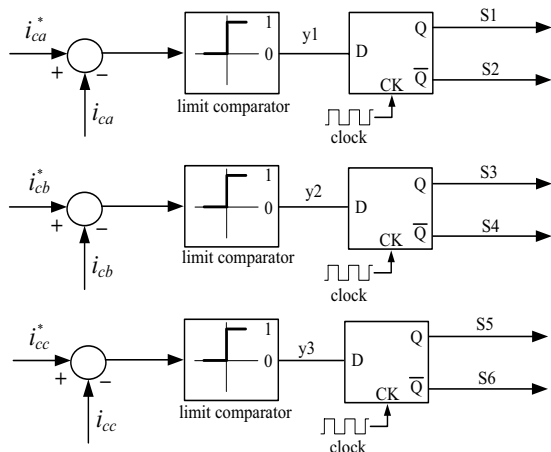

Fig. 6 The block diagram of the delta modulation current control

The delta modulation current control (DMC) is also based on a nonlinear control as shown in Fig. 6. From this figure, the limit comparators and D-type flip-flops are applied to generate the switching signals of six IGBTs. The concept of the delta modulation current control technique is simple and easy to implementation. In Fig. 6 for phase *a*, if  $i_{ca}$  is over than  $i_{ca}^*$  then the comparator output (y1) is 0. In contrast, if  $i_{ca}$  is less than  $i_{ca}^*$  then y1 is 1. This output is transferred to D-type flip-flop for generating the switching pulses. The output of D-type flip-flop (Q or S1) is determined by the clock signal as shown in Fig.7. When the clock signal changes from 0 to 1, S1 is set equal to the output of comparator (y1). The signal S2 or  $\bar{Q}$  is the opposite state of the switching pulse S1.

The switching frequency of delta modulation current control technique is not constant. The maximum switching frequency ( $f_{s,max}$ ) for this technique can be calculated by (8) [11], where  $f_{clock}$  is the frequency of the clock signal.

$$f_{s,max} = f_{clock}/2 \quad (8)$$

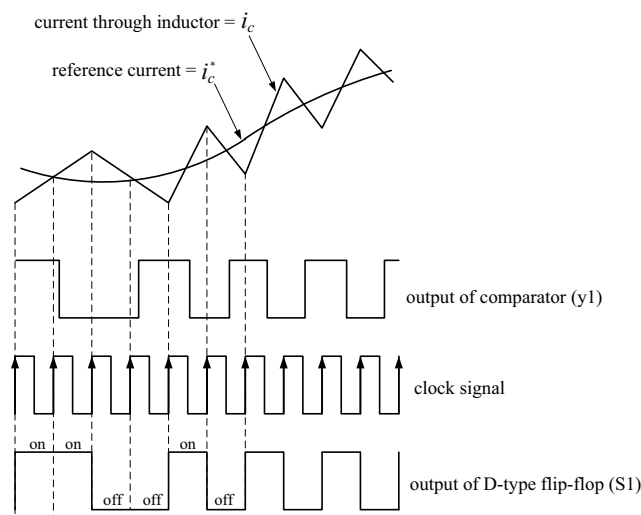

Fig. 7 The basic concept of the delta modulation current control

### C. Carrier-Based PWM Current Control

The carrier-based PWM current control (CPWM) scheme is a linear control. The block diagram of this technique is shown in Fig. 8. In this figure, the difference between the reference currents ( $i_{ca}^*, i_{cb}^*, i_{cc}^*$ ) and the compensating currents ( $i_{ca}, i_{cb}, i_{cc}$ ) are sent to the proportional-integral (PI) controllers to generate the reference voltages ( $u_{ca}^*, u_{cb}^*, u_{cc}^*$ ). These voltages are compared with the triangular carrier signals by using the limit comparators to generate the switching pulses of six IGBTs.

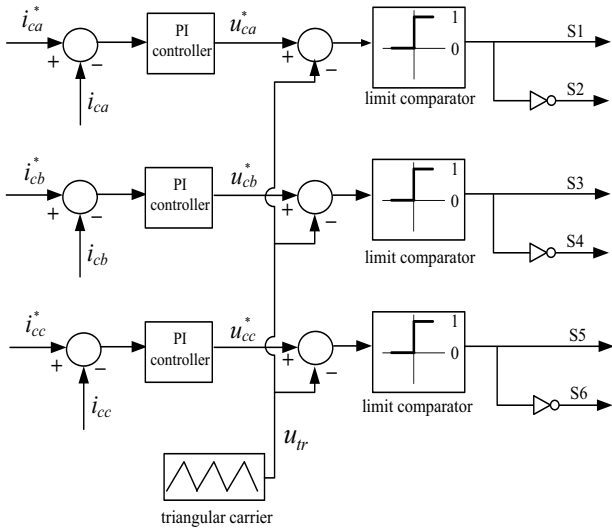

Fig. 8 The block diagram of carrier-based PWM current control

The principle of the carrier-based PWM current control is illustrated in Fig. 9. For example in phase *a*, if the reference voltage ( $u_{ca}^*$ ) is over than the triangular carrier voltage ( $u_{tr}$ ) then the comparator output is 1 ( $S1=1, S2=0$ ). If  $u_{ca}^*$  is less than  $u_{tr}$  then the comparator output is 0 ( $S1=0, S2=1$ ).

The switching frequency of this technique is constant and it is equal to the frequency of triangular carrier ( $f_{tr}$ ) signal [12].

This value can be designed by the maximum order of harmonic component considered for elimination.

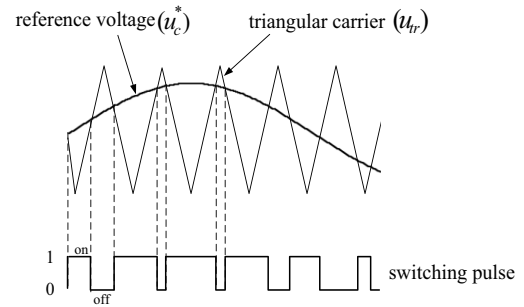
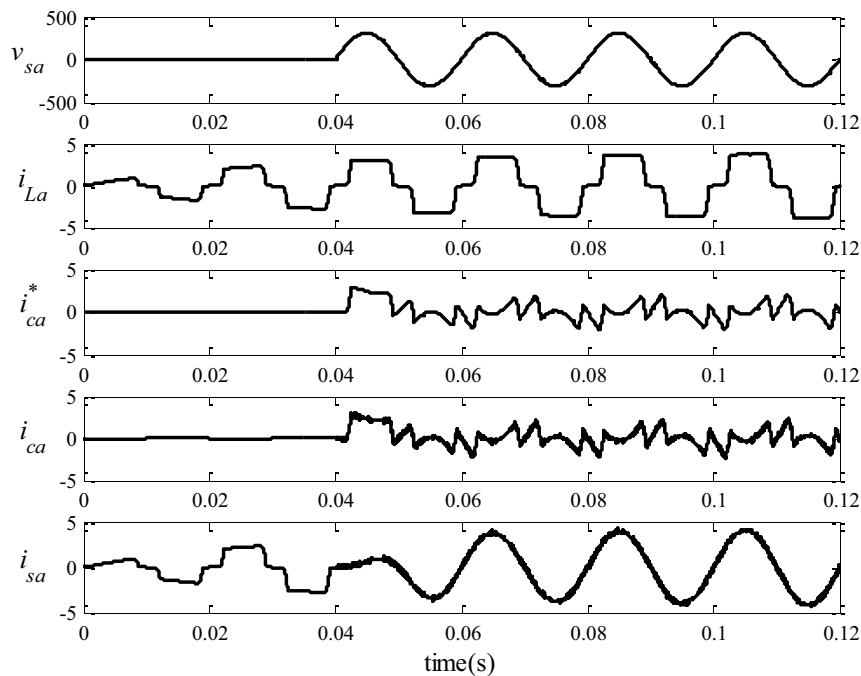

Fig. 9 The basic concept of carrier-based PWM current control

#### IV. SIMULATION RESULTS AND DISCUSSION

The three current control techniques described in previous section are applied to control the current injection of shunt active power filter. In Fig. 1, the DC bus voltage ( $V_{dc}$ ) and inductor ( $L_f$ ) values are set to 750 V and 39 mH, respectively. These parameters are designed by adaptive tabu search (ATS) method [13]. The hysteresis band (HB) for hysteresis current control is equal to 40 mA. The clock frequency ( $f_{clock}$ ) for delta modulation current control is set to 200 kHz and the triangular frequency ( $f_{tr}$ ) of carrier-based PWM current control is set to 10 kHz. Moreover,  $k_p$  and  $k_i$  values for carrier-based PWM current control are equal to 5 and 1000, respectively [14].



(a) The simulation results of hysteresis current control (HCC)

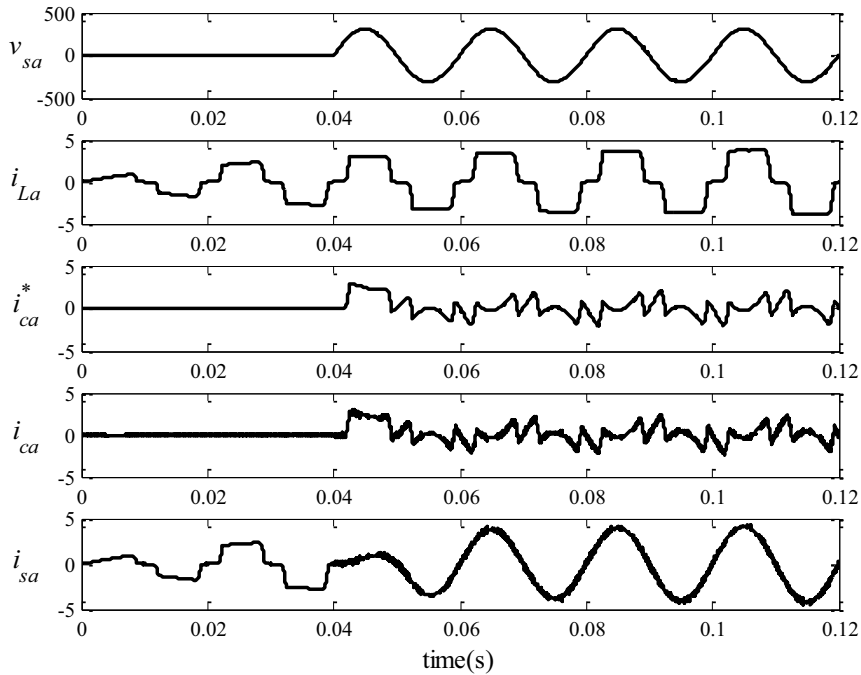

(b) The simulation results of delta modulation current control (DMC)

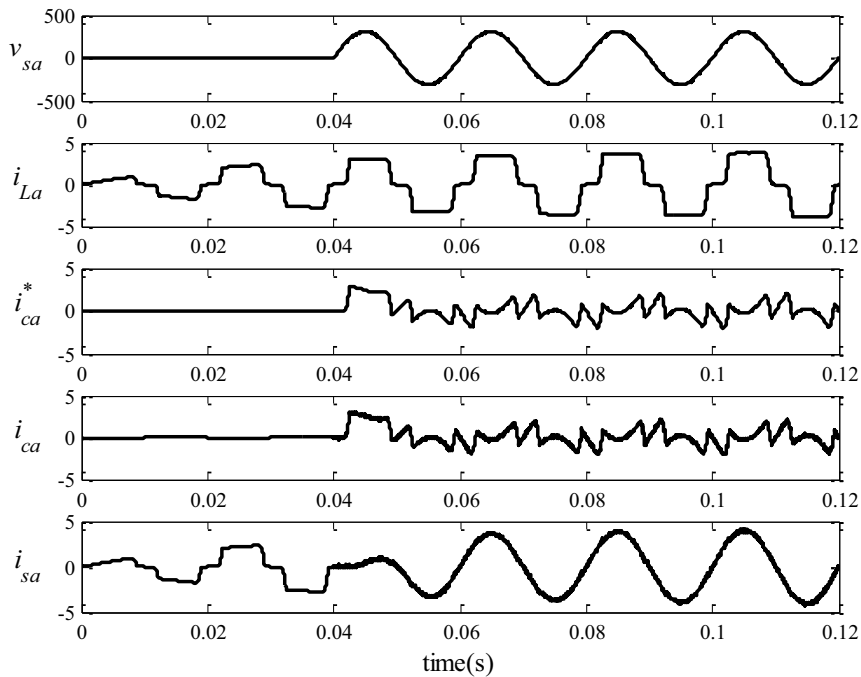

(c) The simulation results of carrier-based PWM current control (CPWM)

Fig. 10 The simulation results of harmonic elimination

The simulation results of phase  $a$  with three current control methods are shown in Fig. 10. The performance index in the paper for comparison study is the average total harmonic distortion ( $\%THD_{av}$ ). This value can be calculated by (9). From the simulation results in Fig. 10, the source currents are

highly distort waveforms and  $\%THD_{av}$  of these currents is equal to 25.50% as shown in Table I. In the paper, the compensating currents from shunt active power filter ( $i_{ca}$ ) inject into the system at  $t=0.04$  s. It can be seen that the source currents after compensation ( $i_{sa}$ ) are nearly sinusoidal

waveform. From Table I, the %THD<sub>av</sub> of these currents for hysteresis current control (HCC), delta modulation current control (DMC) and carrier-based PWM current control (CPWM) are equal to 3.67% 4.39% and 3.32%, respectively.

$$\%THD_{av} = \sqrt{\frac{\sum_{k=a,b,c} \%THD_k^2}{3}} \quad (9)$$

In Table I, the results after compensation using CPWM technique can provide the minimum %THD<sub>av</sub> compared with HCC and DMC techniques. It means that the CPWM technique is the best method for the proposed system to control the current injection of shunt active power filter. However, the %THD<sub>av</sub> values of three techniques can be satisfied under IEEE Std. 519-1992.

TABLE I  
THE PERFORMANCE COMPARISON OF CURRENT CONTROL TECHNIQUES

%THD <sub>av</sub> of source current	Current control techniques		
	HCC	DMC	CPWM
%THD <sub>av</sub> before compensation		25.50%	
%THD <sub>av</sub> after compensation	3.67%	4.39%	3.32%

## V. CONCLUSION

This paper presents the comparison study of three current control approaches for shunt active power filter. The hysteresis current control, the delta modulation control and the carrier-based PWM control are selected to consider the performance comparison. The synchronous detection method is applied to calculate the reference currents for shunt active power filter. The comparison results show that the carrier-based PWM control technique is the best method to obtain the minimum %THD<sub>av</sub> after compensation. However, the %THD<sub>av</sub> values of all three techniques can follow the IEEE std.519-1992.

## ACKNOWLEDGMENT

This work was supported by Suranaree University of Technology (SUT) and by the office of the Higher Education Commission under NRU project of Thailand.

## REFERENCES

- [1] IEEE Std. 519-1992, "IEEE Recommended Practices and Requirements for Harmonic Control in Electrical Power Systems", 1993.
- [2] F. Zhuo, J. Yang, J. Hu, and Z. Wang, "Study on Active Power Filter used in Three-Phase Four Wire System", *Proceedings of the Power Electronics and Motion Control Conference*, vol.3, pp. 1037-1040, 2000.
- [3] C. E. Lin, C.L. Chen, and C. L. Huang, "Reactive and Harmonic Current Compensation for Unbalanced Three-phase Systems Using Synchronous Detection Method", *Journal of Electrical Power System Research*, vol.1.26, pp. 163-170, 1993.

- [4] M. Kale, and E. Ozdemir, "A Novel Adaptive Hysteresis Band Current Controller for Shunt Active Power Filter", *IEEE Conference on Control Applications, CCA 2003*, pp.75 -82, 2003.
- [5] L. Jun, and W. Dazhi, "Study and Simulation of a Novel Hysteresis Current Control Strategy", *IEEE International Conference on Intelligent Computation Technology and Automation*, pp.306-309, 2009.
- [6] P. D. Ziogas, "The Delta Modulation Technique in Static PWM Inverters", *IEEE Transactions on industry applications*, vol. IA-17, no.2, pp. 199-204, 1981.
- [7] M. A. Rahman, J. E. Quaicoe, and M. A. Choudhury, "Performance Analysis of Delta Modulated PWM Inverters", *IEEE Transactions on power electronics*, vol. PE-2, no.3, pp. 227-233, 1987.
- [8] J-H Kim, and S-K. Sul, "A Carrier-Based PWM Method for Three-Phase Four-Leg Voltage Source Converters", *IEEE Transaction on Power Electronics*, vol.19, no.1, pp. 66-75, 2004.
- [9] A. I. Maswood, and E. Al-Ammar, "Analysis of a PWM Voltage Source Inverter with PI Controller under Non-ideal conditions", *IEEE Conference IPEC-2010*, pp.193-198, 2010.
- [10] D.M.E. Ingram, and S. D. Round, "A Novel Digital Hysteresis Current Controller for an Active Power Filter", *IEEE International Conference on Power Electronics and Drive Systems*, pp. 744-749, 1997.
- [11] J. W. Kimball, P. T. Krein, and Y. Chen, "Hysteresis and Delta Modulation Control of Converters Using Sensorless Current Mode", *IEEE Transactions on power electronics*, vol. 21, no. 4, pp. 1154-1158, 2006.
- [12] D. Chen and S. Xie, "Review of the control strategies applied to active power filters", *IEEE International Conference on Electric Utility Deregulation, Restructuring and Power Technologies (DRPT2004)* pp.666-670,2004.
- [13] T. Narongrit, K-L. Areerak and A. Srikaew, "Design of an Active Power Filter using Adaptive Tabu Search", *Proceedings of the 8<sup>th</sup> WSEAS International Conference on Artificial Intelligence*, pp. 314 – 318, 2009.
- [14] L. Moran, P. Godoy, R. Wallace and J. Dixon, "A new current control strategy for active power filters using three PWM voltage source inverters", *IEEE Power Electronics Specialists Conference, PESC '93*, pp. 3-9, 1993.

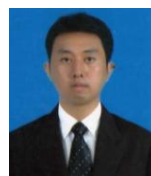

T. Narongrit received the B.Eng. and M.Eng degrees in electrical engineering from Suranaree University of Technology (SUT), Thailand, in 2008 and 2010, In now (2011), studying in Ph.D degree in electrical engineering of SUT. He has been a member of Power Quality Research Unit (PQRU) in the School of Electrical Engineering, SUT. His main research interests include active power filter, harmonic elimination, intelligence control system and AI application.



K-L. Areerak received the B.Eng, M.Eng, and Ph.D. degrees in electrical engineering from Suranaree University of Technology (SUT), Thailand, in 2000, 2003, and 2007, respectively. Since 2007, he has been a lecturer and Head of Power Quality Research Unit (PQRU) in the School of Electrical Engineering, SUT. He received the Assistant Professor in Electrical Engineering in 2009. His main research interests include active power filter, harmonic elimination, artificial intelligence applications, motor drive, and intelligence control systems.



K-N. Areerak received the B.Eng. and M.Eng degrees from Suranaree University of Technology (SUT), Nakhon Ratchasima, Thailand, in 2000 and 2001, respectively and the Ph.D. degree from the University of Nottingham, Nottingham, UK., in 2009, all in electrical engineering. In 2002, he was a lecturer in the Electrical and Electronic Department, Rangsit University, Thailand. Since 2003, he has been a Lecturer in the School of Electrical Engineering, SUT. His main research interests include system identifications, artificial intelligence applications, stability analysis of power systems with constant power loads, modeling and control of power electronic based systems, and control theory.