

Assessment of Reliability and Quality Measures in Power Systems

Badr M. Alshammari and Mohamed A. El-Kady

Abstract—The paper presents new results of a recent industry supported research and development study in which an efficient framework for evaluating practical and meaningful power system reliability and quality indices was applied. The system-wide integrated performance indices are capable of addressing and revealing areas of deficiencies and bottlenecks as well as redundancies in the composite generation-transmission-demand structure of large-scale power grids. The technique utilizes a linear programming formulation, which simulates practical operating actions and offers a general and comprehensive framework to assess the harmony and compatibility of generation, transmission and demand in a power system. Practical applications to a reduced system model as well as a portion of the Saudi power grid are also presented in the paper for demonstration purposes.

Keywords—Power systems, Linear programming, Quality assessment, Reliability.

I. INTRODUCTION

IN response to the growing interest in system security and reliability by power utilities, several schools of thought have evolved with the associated pioneering research aimed at conducting the security and reliability assessment in an efficient, accurate manner and with as much realization of the business nature and practical circumstances of the power utility as possible. In this respect, power system security, reliability and quality analyses have evolved over the years from mere theoretical topics of limited interest, during the era of generous economy and abundant supply and facilities, to a vital branch in today's highly-competitive business environment of power utility planning and operations [1-3].

As has happened with many power system disciplines, the prime interest in system security, adequacy and reliability has gradually shifted from completing and refining the theoretical basis, through developing suitable computational tools for demonstrating the capability and practicality of the methodologies, to upgrading the computational tools to handle the large-scale nature of present power systems.

Furthermore, considerable attention is given to relate various security, quality and reliability indices to the practical

B.M. Alshammari is with the Saudi Electricity Company Chair in Power System Reliability and Security, College of Engineering, King Saud University, P.O. Box 800, Riyadh 11421, Saudi Arabia (Email: badr_ms@hotmail.com).

M.A. El-Kady is with the Saudi Electricity Company Chair in Power System Reliability and Security, College of Engineering, King Saud University, P.O. Box 800, Riyadh 11421, Saudi Arabia (Email: melkady@ksu.edu.sa).

concerns of utility engineers and executives regarding supply and/or transmission deficiencies as well as the risk associated with ignoring such deficiencies [4,5].

In this paper, an efficient computerized scheme is employed for effective and meaningful evaluation of the overall system performance quality measures and the expected impact on these quality measures due to changes in the available power network capacities. The scheme utilizes a basic linear programming formulation which simulates practical operating actions and offers a general and comprehensive framework to assess the harmony and compatibility of generation, transmission and demand in power systems. This computer-aided assessment can reveal, in an efficient and reliable manner, areas of deficiencies and bottle-necks in various portions of the system as well as excess and surplus facilities in the system [6].

Using the method described in this paper, integrated system quality assessment can be performed globally on the whole system or locally on portions in the power grid. It can be applied to the system under normal operation or subject to contingencies with certain or random occurrences [7-9]. The methodology presented in this paper has been implemented in an efficient computerized algorithm which analyzes the network structure, generation and load balance and evaluates various composite system quality indices of practical interest to power system engineers.

II. PROBLEM FORMULATION

Let n_B = number of buses in the power network, where $n_B = n_L + n_G$, n_L and n_G = number of load and generator buses, respectively. Also, in the network model used, n_T = number of transmission branches (lines and transformers).

In order to facilitate subsequent formulation, it is assumed, without loss of generality, that the load buses are numbered as 1, 2, ..., n_L followed by generator buses as $n_L + 1$, ..., $n_L + n_G$, where $n_L + n_G = n_B$. For example, the sample power system shown in Figure 1 has $n_B = 4$, $n_G = 2$, $n_L = 2$ and $n_T = 5$.

Now, let $\mathbf{A} = (n_B \times n_T)$ be the bus incidence matrix representing the connectivity pattern between buses and lines. The entries of \mathbf{A} are either 0, 1 or -1. Therefore, an element $A_{bt} = 1$ if bus b is feeding a transmission branch t ; $A_{bt} = -1$ if bus b is fed from a branch t , otherwise $A_{bt} = 0$. Note also that for practical large-scale networks, the matrix \mathbf{A} is extremely sparse.

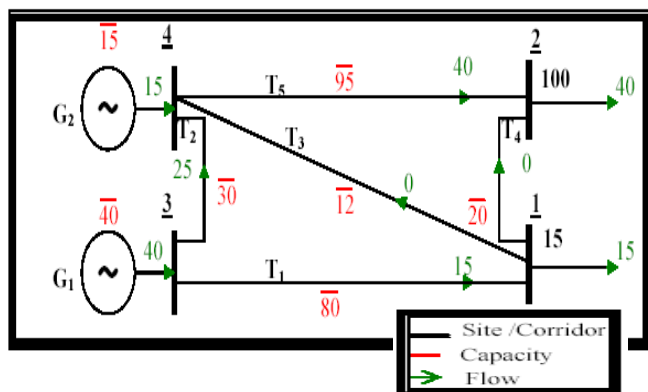

Fig. 1 A Sample power system

III. QUALITY ASSESSMENT

Although the basic definitions pertaining to integrated system quality are simple to state and often seem intuitive at first glance, a great deal of care should be exercised in order to recognize some subtle differences in the definition and formulation of the composite quality indices. Let,

- \bar{P}_T = vector of n_T elements representing transmission branch capacities
- \bar{P}_L = vector of n_L elements of peak bus loads
- \bar{P}_G = vector of n_G elements representing generator capacities

For simplicity of notation, we shall use \bar{P}_t to denote a general element t of the vector \bar{P}_T (rather than the more strict notation of \bar{P}_{Tt}). Similarly, we shall use \bar{P}_l and \bar{P}_g to denote general elements of \bar{P}_L and \bar{P}_G , respectively. However, when confusion may occur, we will use the strict notation of \bar{P}_{Tt} , \bar{P}_{Ll} and \bar{P}_{Gg} . If, for example the local generation capacity \bar{P}_g at bus g exceeds the corresponding transmission capability $\sum_{t \in T_g} \bar{P}_t$, where T_g denotes the set of

transmission branches connected to generator bus g , then using the terminology introduced in the previous section, we may say that a positive amount of $(\bar{P}_g - \sum_{t \in T_g} \bar{P}_t)$ of generation beyond bus g has been bottled (blocked from usage).

IV. MASTER LINEAR PROGRAM

In the proposed scheme, the integrated system quality assessment is performed via solving a master linear programming problem [10] in which a feasible power flow is established which minimizes the total system non-served load subject to capacity limits and flow equations.

The master linear program, which utilizes the network bus incidence matrix A , is formulated as

$$\text{Minimize } f = \sum_{i=1}^m (\bar{P}_i - P_i)$$

with respect to P_L , P_G and P_T

such that

$$A P_T = \begin{bmatrix} -P_L \\ P_G \end{bmatrix}$$

$$\begin{aligned} P_L &\leq \bar{P}_L, -P_L \leq 0 \\ P_G &\leq \bar{P}_G, -P_G \leq 0 \\ P_T &\leq \bar{P}_T, -P_T \leq \bar{P}_T \end{aligned}$$

In the master linear program, P_L , P_G , and P_T are n_L , n_G and n_T column vectors representing the actual load bus powers (measured outward), generator bus powers (measured inwards) and transmission line powers (measured as per the network bus incidence matrix A), respectively. The solution of the above linear program provides a more realistic (less conservative) flow pattern in view of the fact that when load curtailments are anticipated, all system generation resources would be re-dispatched in such a way which minimizes such load cuts. The feasible flow pattern established from the Master Linear Program is then used to evaluate various integrated system quality indices through a set of closely related sub-problems. For example, to evaluate the total system loss of load subject to a given contingency scenario, the sum of all elements of the P_L vector is subtracted from the total nominal system load. The resulting amount, if positive, would constitute the total system loss of load (load supply deficiency).

V. QUALITY MEASURES

The followings are examples of system quality measures defined and evaluated based on the Master Linear Program described in the previous section.

1. Load Not-Served:

The load not-served (LNS) index is given by

$$\text{LNS} = \sum_{l=1}^{n_L} (\bar{P}_l - P_l)$$

where

n_L = number of load buses

\bar{P}_l = required demand at load bus l

P_l = actual supplied demand at load bus l

which represents the forced load cuts in the system.

2. Utilized Generation:

The utilized generation index (UG) is defined as the total load served in the power system, that is

$$UG = \sum_{l=1}^{n_L} (P_l)$$

where

n_L = number of load buses

P_l = actual supplied demand at load bus l

3. Bottled Generation:

The bottled generation index (BG) is defined as the system generation which is needed to supply the demand but cannot reach the respective load buses. That is

$$BG = \begin{cases} (\sum_{g=1}^{n_G} \overline{P}_g - \sum_{l=1}^{n_L} P_l), & \text{if } \sum_{g=1}^{n_G} \overline{P}_g \leq \sum_{l=1}^{n_L} P_l \\ (\sum_{l=1}^{n_L} \overline{P}_l - \sum_{l=1}^{n_L} P_l), & \text{if } \sum_{g=1}^{n_G} \overline{P}_g > \sum_{l=1}^{n_L} P_l \end{cases}$$

where

n_L = number of load buses

n_G = number of generator buses

\overline{P}_l = required demand at load bus l

P_l = actual supplied demand at load bus l

\overline{P}_g = available generator capacity at bus g

VI. APPLICATION OF PERFORMANCE QUALITY ASSESSMENT

The developed methodology for power system performance quality assessment has been applied to a practical power system comprising a portion of the interconnected Saudi power grid shown in Figure 2. The power system consists of two main regions, namely the Central region and the Eastern region. The two systems are interconnected through two 380 kV and one 230 kV double-circuit lines. For demonstration purposes, several severe contingencies were simulated involving loss of three major interfaces as well as one major power plant. Subsequently, a reduced network model was generated using static network reduction software to yield the reduced 4-bus system model previously shown in Figure 1. All load, flow and capacity values in Figure 1 are in MW. It is to be noted that the generation and transmission element capacities shown in Figure 1 are for illustration purposes only and may not reflect the actual element values.

Table I summarizes the quality performance measures applied to the reduced system model of Figure 1 for different values of the generation capacity G_1 (at bus #3) and the transmission capacity of line T_1 .

TABLE I
 SYSTEM QUALITY PERFORMANCE ASSESSMENT MEASURES FOR TWO OPERATING SCENARIOS

| G_1 Capacity | T_1 Capacity | UG | BG | LNS |
|-------------------|-------------------|----|----|-----|
| 40 | 10 | 55 | 0 | 60 |
| | 45 | 55 | 0 | 60 |
| | 80 | 55 | 0 | 60 |
| 110 | 10 | 55 | 60 | 60 |
| | 45 | 90 | 25 | 25 |
| | 80 | 92 | 23 | 23 |
| 180 | 10 | 55 | 60 | 60 |
| | 45 | 90 | 25 | 25 |
| | 80 | 92 | 23 | 23 |

When the entire system of Figure 2 was analyzed in regard to generation bottling, three contingency scenarios were simulated involving combinations of the loss of one or more E-C tie-lines at both peak and off-peak load levels during a heavy demand season. For demonstration purposes, the original system base-case was modified to include hypothetical worst-case scenarios regarding the on-maintenance availability of several system elements. Table II summarizes the generation bottling results obtained for the three simulated scenarios.

TABLE II
 BOTTLED GENERATION RESULTS FOR THREE OPERATING SCENARIOS

| # | Scenario Description | BG (MW) |
|---|--|------------|
| 1 | Loss of one 380 kV E-C tie-line during peak load period. | 630 |
| 2 | Loss of one 380 kV E-C tie-line during off-peak load period. | 0 |
| 3 | Loss of one 380 kV E-C tie-line together with the 230 kV E-C tie-line during off-peak load period. | 440 |

Because most of the system generation is located in the Eastern region with the demand at the Central region dependent to some degree on the Eastern region's generation, the loss of one 380 kV E-C tie-line during peak load period would result in a 630 MW. This situation would not occur during the off-peak period with the same contingency. However, the double contingency involving the additional loss of the 230 kV E-C tie-line (coupled with the loss of one 380 kV E-C tie-line) would cause 440 MW of generation bottling even during the off-peak load period. This application demonstrates the importance of evaluating the bottled generation index for various potential system contingencies to ensure that the transmission network is adequate to transfer the already available generation to the load centers.

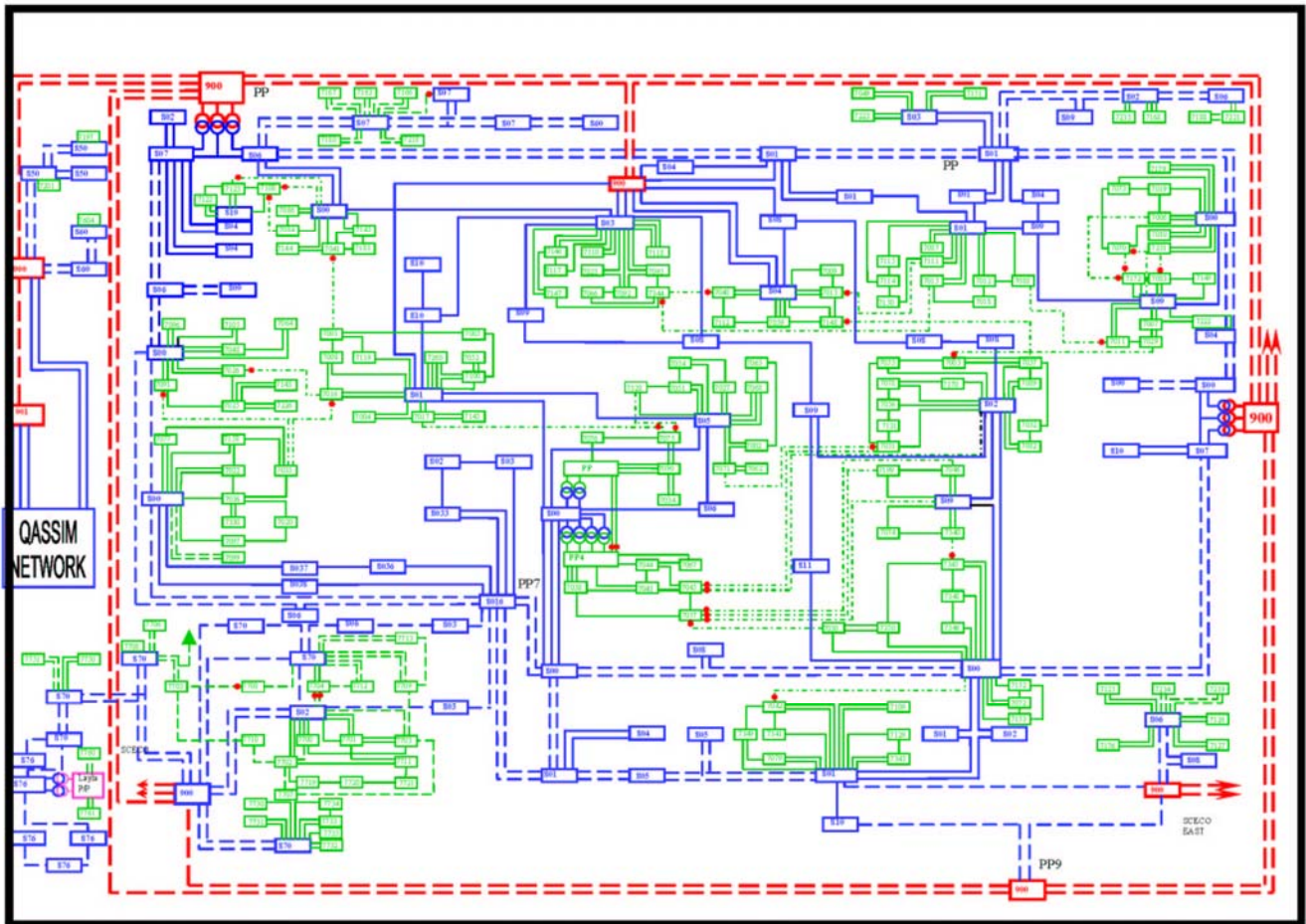

Fig. 2 Single-line diagram of study power system

VII. CONCLUSION

This paper has shared the findings and results of a recent industry supported study to use overall integrated quality indices to assess the performance of large-scale power systems. The integrated quality indices presented in this paper can be used for effective and meaningful evaluation of the overall system quality measures by utilizing a linear-programming-based formulation of the problem which simulates the power system behavior under normal and contingency situations.

Through the quality assessment formulation introduced in the paper, a comprehensive framework is established together with a proper methodology to assess the harmony and compatibility of generation, transmission and demand in power systems. This computer-aided assessment can reveal, in an efficient and reliable manner, areas of deficiencies and bottle-necks in various portions of the system. Furthermore, using the method proposed, integrated system quality assessment can be performed globally on the whole system or locally on portions or even nodes (buses) in the power grid.

Based on the solution of the basic linear program described in this paper, a more realistic (less conservative) flow pattern can be established. The more realistic nature of such a flow pattern comes from the fact that when load curtailments are anticipated, all system generation resources would be re-dispatched in such a way which minimizes such load cuts. Examples of such quality measures are the none-served load, utilized generation and bottled generation.

While the system quality indices are valuable on their own, the expected impact on these quality indices due to changes in the available power network capacities represent useful information, which can be used to assess the level of degradation in the quality index under consideration as demonstrated in the paper.

ACKNOWLEDGMENT

This work was supported by the Saudi Electricity Company (SEC) which funds the SEC Chair in Power System Reliability and Security.

REFERENCES

- [1] S.D Torre, A.J. Conejo, and J. Contreras, "Transmission Expansion Planning in Electricity Markets", *IEEE Transactions on Power Systems*, vol. 23, no. 1, pp. 238-248, February 2008.
- [2] M.A. El-Kady, M.S. El-Sobki and N.K. Sinha, "Reliability evaluation for optimally operated large electric power systems", *IEEE Transactions on Reliability*, vol. R-35, no. 1, pp. 41-47, 1986.
- [3] M.A. El-Kady, M.S. El-Sobki and N.K. Sinha, "Loss of load probability evaluation based on real time emergency dispatch", *Canadian Electrical Engineering Journal*, vol. 10, pp. 57-61, 1985.
- [4] C. Qiming, L. Yan Lin and J.D. McCalley, "The Risk of High-Order Transmission Contingencies", *Proc. IEEE Power Engineering Society General Meeting*, pp. 1-7, June 2007.
- [5] M.A. El-Kady, B. A. Alaskar, A.M. Shaalan and B.M. Al-Shammri, "Composite reliability and quality assessment of interconnected power systems", *International Journal for Computation and Mathematic in Electrical and Electronic Engineering (COMPEL)*, vol. 26, no. 1, Paper SSD05-PES-12, 2007.
- [6] B.M. Alshammari, M.A. El-Kady and Y.A. Al-Turki, "Computer-Aided Optimization of Power System Performance Quality Indices", *Proc. 3rd Global Conference on Power Control and Optimization*, Gold Coast, Australia, 2010, Paper 51.
- [7] J. Choi, T.D. Mount and R.J. Thomas, "Transmission Expansion Planning Using Contingency Criteria", *IEEE Transactions on Power Systems*, vol. 22, no. 4, pp. 2249-2261, November 2007.
- [8] P. Jirutitijaroen and C. Singh, "Reliability Constrained Multi-Area Adequacy Planning Using Stochastic Programming With Sample-Average Approximations", *IEEE Transactions on Power Systems*, vol. 23, no. 2, pp. 405-513, May 2008.
- [9] N. Maruejols, V. Sermanson, S.T. Lee. And P. Zhang. "A practical probabilistic reliability assessment using contingency simulation", *Proc. IEEE Power Systems Conference and Exposition*, vol.3, pp. 1312-1318, October 2004
- [10] P.E. Gill, W. Murray and M.H. Wright, *Practical Optimization*, Academic Press, 1981.

B.M. Alshammari Obtained his B.Sc. and M.Sc degree from King Saud University, Riyadh, Saudi Arabia in 1998 and 2004, respectively.

He is currently working toward his Ph.D. degree at King Saud University in the area of reliability and security assessment. His main research area of interest is Power System Reliability and Optimized Performance of Electricity Systems.

Eng. Alshammari is currently a Lecturer at the Technical College in Hail, Saudi Arabia.

M.A. El-Kady Received his Ph.D. from McMaster University, Canada in 1980. Since then, he has held a dual University/Industry career both at McMaster University and Ontario Hydro, Canada. At McMaster University, he progressed through academic ranks until he became a Professor in 1991 while teaching and supervising research and development activities in power system planning and operation. At Ontario Hydro, he progressed through several engineering and management positions where he ultimately filled the position of Development Planning Manager in 1986.

He has been (since 1993) with the Electrical Engineering Department, King Saud University, Saudi Arabia. He has authored and co-authored over 300 publications in various power system and engineering topics. In addition to his academic activities, he has also been participating in industry funded projects and studies on issues relating to re-structuring of power utilities, energy market studies, development of bulk electricity plans, standardization of electricity services, energy efficiency, and environmental assessment.

Dr. El-Kady has through his career served on several IEEE, and CEA (Canadian Electric Association) committees and taskforces. He is also the Chairman of the Technical Committee #1 in SASO (Saudi Arabian Standardization Organization) He has been project manager and principal investigator of several industry, government and internationally-funded R & D projects, including projects from Electric Power Research Institute (EPRI), CEA, Natural Sciences and Engineering Research Council of Canada (NSERC), Saudi Electricity Company (SEC), Ministry of Water and Electricity in Saudi Arabia, Saudi Arabian Basic Industries Corporation (SABIC), Saudi Telecom Company (STC) and King Abdulaziz City for Science and Technology (KACST) in Saudi Arabia..