

# A parametric Study on Deoiling Hydrocyclones Flow Field

Maysam Saidi, Reza Maddahian, Bijan Farhanieh

**Abstract**—Hydrocyclones flow field study is conducted by performing a parametric study. Effect of cone angle on deoiling hydrocyclones flow behaviour is studied in this research. Flow field of hydrocyclone is obtained by three-dimensional simulations with OpenFOAM code. Because of anisotropic behaviour of flow inside hydrocyclones LES is a suitable method to predict the flow field since it resolves large scales and model isotropic small scales. Large eddy simulation is used to predict the flow behavior of three different cone angles. Differences in tangential velocity and pressure distribution are reported in some figures.

**Keywords**—Deoiling hydrocyclones, Flow field, Hydrocyclone cone angle, Large Eddy Simulation, Pressure distribution

## I. INTRODUCTION

HYDROCYCLONES are used in wide range of applications to separate different materials from liquids. Compactness, efficiency, reliability and low maintenance costs are their noteworthy characteristics. Although hydrocyclones have been used for industrial purposes more than hundred years but recently, the need for having high efficiency compact separators during various operating conditions has attracted the interest of researchers to them. Dewatering hydrocyclones to refine crude oil [1] and deoiling hydrocyclones to refine oily waste water in offshore platforms [2,3] are examples of liquid-liquid hydrocyclones. Separation process in hydrocyclones is based on swirl flow induces a centrifugal force and leads to separation because of density difference. The density difference in liquid-liquid mixtures is smaller than solid-liquid types and trying to separate one liquid from another takes much more effort than while separating solid from liquid. Another difference in deoiling hydrocyclones is that centrifugal force makes solid particles migrate to the wall region in desander hydrocyclones while making oil droplets move to the center in the deoiling types. So the near wall region is of high importance in desander hydrocyclones. In the meantime, attention is drawn to the center flow features in the deoiling types.

The first idea of using common hydrocyclones for oil-water separation was suggested by Simkin and Olney [4] and Sheng, Welker and Sliepcevic [5] but fundamental studies on deoiling hydrocyclones were started from 1980 by Colman and Thew.

M. Saidi is PhD Student at Mechanical Engineering Department of Amirkabir University of Technology (Tehran Polytechnic), 424 Hafez Ave, P.O. 15875-4413, Tehran, Iran (Phone: +98-21-64543410; Fax: +98-21-66419736; Email: maysam.saidi@aut.ac.ir).

R. Maddahian is PhD Student at Mechanical Engineering Department of Sharif University of Technology, Tehran, Iran (Email: r\_maddahian@mech.sharif.edu).

B. Farhanieh is Professor at Mechanical Engineering Department of Sharif University of Technology, Tehran, Iran (Email: bifa@sharif.edu).

Several experimental researches on deoiling hydrocyclones were conducted by Colman [6], Colman, Thew and Corney [7] and Colman and Thew [8]-[9]. Having a optimize geometry is one of researchers interest. Delagadillo and Rajamani [10] simulated a 75 mm cyclone and compare three different turbulence models (k- $\epsilon$ , RSM, LES). LES captured the characteristics of the dynamics of the flow which allow the accurate prediction of the flow field and VOF model was used for air core prediction. Delagadillo and Rajamani [11,12] used LES to optimize hydrocyclone geometry. They used Fluent software and did modifications in geometry to improve classification and efficiency. Also, they did a study [13] to amenable LES for large hydrocyclones and good results were reported. Saidi et al. [14] demonstrated the capability of LES to predict flow field of deoiling types hydrocyclones. They compared different turbulence models and showed that LES leads to better results than k-  $\epsilon$  and Reynolds Stress Model. Noroozi and Hashemabadi [15,16] investigated the effect of various inlet types and inlet chamber body profiles on the separation efficiency of deoiling hydrocyclones by using Reynolds Stress Model. Water phase has a significant role on separation efficiency because of low concentration of dispersed phase. Hydrocyclone flow is a complex swirling flow and regarding influence of flow field on separation process, exact pressure and velocity field is essential for numerical simulation. Selection of appropriate turbulence model and boundary conditions is the key of a successful simulation. It should be noted that numerical errors can decay results completely. Large eddy simulation is a powerful tool to simulate hydrocyclone. It is for the first time LES used for deoiling types of hydrocyclone. In this study the focus is on flow behavior in deoiling hydrocyclones with different cone angles.

## II. GOVERNING EQUATIONS

The continuity and momentum equation are the equations that are solved in this research. A general low-pass filter is applied to the Navier-Stokes equations to decompose the velocity into resolved and residual components. The large scales affected by flow geometry specify the properties of turbulent flow such as heat and mass transfer and therefore should be resolved. The small scales only dissipate the energy and could be modeled using appropriate subgrid turbulence model.

The decomposed velocity (resolved and residual) components can be written as:

$$u_i = \bar{u}_i + u_i' \quad (1)$$

Applying the decomposed velocity into mass and momentum equations and performing the filtration process, results the following equations:

$$\frac{\partial \bar{u}_i}{\partial x_i} = 0 \quad (2)$$

$$\frac{\partial \bar{u}_i}{\partial t} + \frac{\partial(\bar{u}_i \bar{u}_j)}{\partial x_j} = -\frac{1}{\rho} \frac{\partial \bar{p}}{\partial x_i} + \nu \frac{\partial^2 \bar{u}_i}{\partial x_j \partial x_j} - \frac{\partial \tau_{ij}^{sgs}}{\partial x_j} \quad (3)$$

where  $\tau_{ij}^{sgs}$  is residual stress tensor describes the unresolved scales and can be written as:

$$\tau_{ij}^{sgs} = \overline{u_i u_j} - \bar{u}_i \bar{u}_j \quad (4)$$

Using Eq. (1), the residual stress tensor could be written as:

$$\tau_{ij}^{sgs} = \overline{u'_i u'_j} + \overline{u_i u'_j} + \overline{u'_i u_j} + \overline{u_i u_j} - \bar{u}_i \bar{u}_j \quad (5)$$

Eq. (5) is another representation of residual stress tensor used in dynamic Smagorinsky model.

One of the most typical methods to model residual stress tensor is using eddy viscosity approach defined as below:

$$\tau_{ij}^{sgs} - \frac{\delta_{ij}}{3} \tau_{kk}^{sgs} = -2\nu_t \bar{S}_{ij} \quad (6)$$

where  $\bar{S}_{ij}$  is the strain tensor defined by Eq. (7).

$$\bar{S}_{ij} = \frac{1}{2} \left( \frac{\partial \bar{u}_i}{\partial x_j} + \frac{\partial \bar{u}_j}{\partial x_i} \right) \quad (7)$$

Smagorinsky [17] used following expression to calculate the turbulent kinematic viscosity:

$$\nu_T = (C_S \Delta)^2 |\bar{S}| \quad (8)$$

where  $|\bar{S}| = \sqrt{2\bar{S}_{ij}\bar{S}_{ij}}$  and  $\Delta$  is filter width. Smagorinsky constant ( $C_S$ ) is found to vary in the range of 0.065 [18] to 0.25 [19] depends on flow and geometry. Assuming a constant value for  $C_S$  is one of the weaknesses of Smagorinsky subgrid model and we used the dynamic Smagorinsky model. Germano et al. [20] and Lilly [21] proposed a dynamic SGS model in which  $C_S$  is calculated and is not an arbitrary chosen value. The main idea behind dynamic Smagorinsky model consists in introducing a test filter ( $\hat{\Delta}$ ) with larger width than the original one. This filter is applied to the filtered Navier-Stokes equation. The  $C_S$  would be:

$$C_S = -\frac{1}{2} \frac{\langle L_{ij} M_{ij} \rangle}{\langle M_{ks} M_{ks} \rangle} \quad (9)$$

where  $L_{ij} = \overline{\overline{u_i u_j}} - \overline{\overline{u_i}} \overline{\overline{u_j}}$  and  $M_{ij} = [\hat{\Delta}]^2 |\hat{S}| - \hat{\Delta}^2 |\bar{S}|$ .

### III. GEOMETRY, GRID AND FLOW CONDITION

Simulations are performed on hydrocyclones with 35 mm of diameter and two symmetrical inlets (5mm\*10 mm) enter

tangentially from top of their cylindrical section. The hydrocyclone has two outlets, one at its top and the other at its end named overflow and underflow respectively. Overflow is continued to internal of the hydrocyclone with the length of  $L_0$  and called vortex finder.

Three different studied designs with cone angles of 6, 10 and 20 degree are depicted in Fig. 1. Dimensions of considered hydrocyclones are shown in Fig. 2. The 6° hydrocyclone is designed for oily waste water refinement having oil concentration less than 0.3 vol. % in inlet by Bai et al. [22].

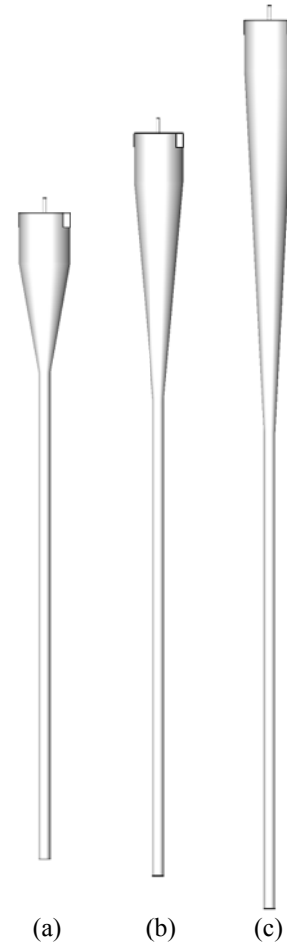

Fig. 1 hydrocyclone geometry with different cone angle, a) 20°, b) 10°, c) 6°

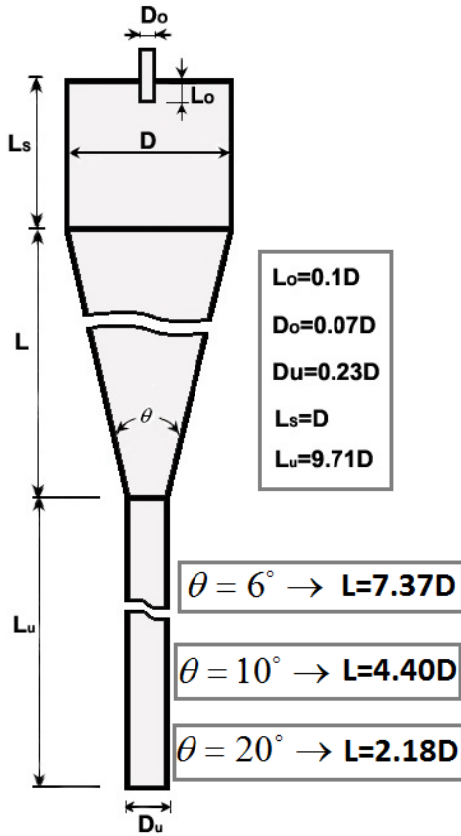

Fig. 2 Hydrocyclone geometry dimensions

Operation parameters are presented in table I. Split ratio (R) is the ratio of flow exits from overflow to inlets.

Figure 3 shows images of grid used in simulation. Except center cylinder with diameter of overflow and vortex finder which is meshed Quad/Pave, it is meshed with Quad/Map. Whole of hydrocyclone is meshed with hexahedral cells.

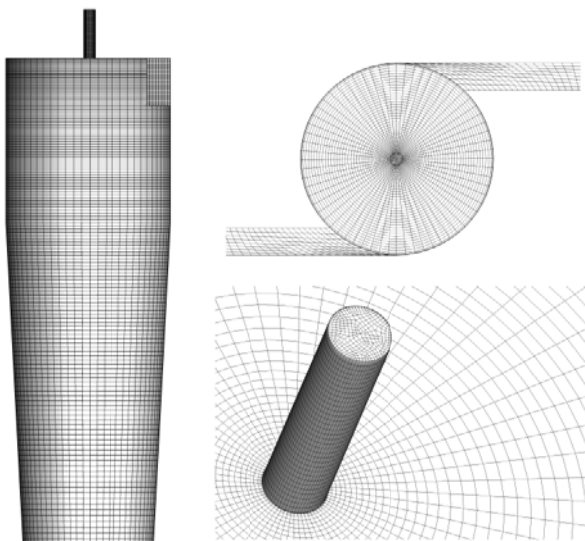

Fig. 3 Generated mesh for hydrocyclone simulation

TABLE I  
 OPERATION PARAMETERS OF HYDROCYCLONE

| $Q_i$<br>( $m^3/h$ ) | R % | $\rho_{water}$<br>( $kg/m^3$ ) | $\mu_{water}$<br>( $kg/m-s$ ) |
|----------------------|-----|--------------------------------|-------------------------------|
| 1.5                  | 5±1 | 1000                           | 0.001                         |

#### IV. NUMERICAL METHOD

An open source CFD code OpenFOAM is used to solve the filtered Navier-Stokes equation. The code is developed based on finite volume solver with collocated grid. The Pressure-Implicit Split Operator (PISO) algorithm handles the linkage between the velocities and pressure (Issa [23]).

Preconditioned conjugate gradient solver for pressure and preconditioned bi-conjugate gradient solver for other parameters are used. Unbounded second order linear central differencing is used for convection and diffusion and backward scheme is used for time which has second order accuracy.

Simulation is started with k-ε turbulence model and switched to LRR (Launder-Reece-Rodi) Reynolds Stress Transport Model. After preliminary convergence the solution is considered as an initial condition of LES model. The considered solution procedure helps the convergence sequence and decrease the computation time. The time steps were changed from  $10^{-6}$  to  $3 \times 10^{-6}$  during the convergence process. The upper limit of courant number was kept less than 0.3.

#### V. RESULTS AND DISCUSSION

For verification of results a comparison between tangential velocity of present work and experimental work of Bai et al. [22] is conducted. Fig. 4 shows this comparison at  $Z/D = 2.29$  for  $6^\circ$  hydrocyclone. The Agreement between experimental and computed numerical results is very good. The general trend of the curve can be predicted in numerical simulations but small deviation is seen for the location of maximum tangential velocity.

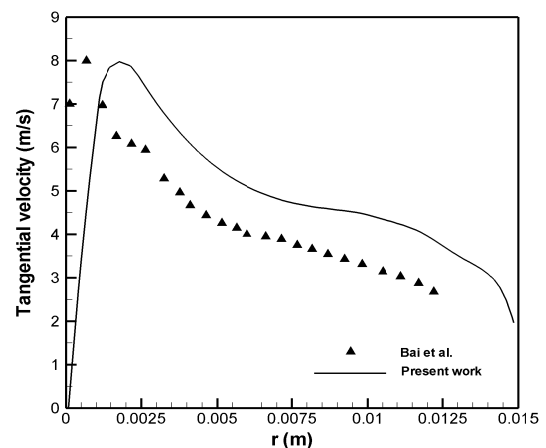

Fig. 4 Tangential velocity at  $Z/D=2.29$

The radial variation of tangential velocity at two cross section of hydrocyclone include top ( $Z = L_s$ ) and bottom (

$Z = L_s + L$ ) of hydrocyclone cone is shown in Fig. 5.a and Fig. 5.b Tangential velocity has a shape of Rankine vortex, i.e. forced vortex near the axes of rotation and free vortex in outer region. The maximum tangential velocity occurs near the axis and decreases towards the wall. Increase of tangential velocity peak and forced vortex sharpness is seen with cone angle increase. Time averaged pressure distribution inside deoiling hydrocyclone for three different cone angles is shown in Fig. 5.c and Fig. 5.d Pressure variation in radial direction is the reason behind secondary vortex in hydrocyclones. The pressure gradient is increased with cone angle.

Radial pressure gradient generated by swirling motion of flow makes the lighter phase migrate toward the center. The greater radial pressure gradient, the higher separation efficiency is. But it should be considered because of increase of velocity in larger cone angle hydrocyclones, settling time for oil droplet decrease and it has negative effect on separation process of hydrocyclone i.e. although pressure gradient increase helps to make better separation but oil droplets have less time for separation because of higher velocity and lower height of cone section.

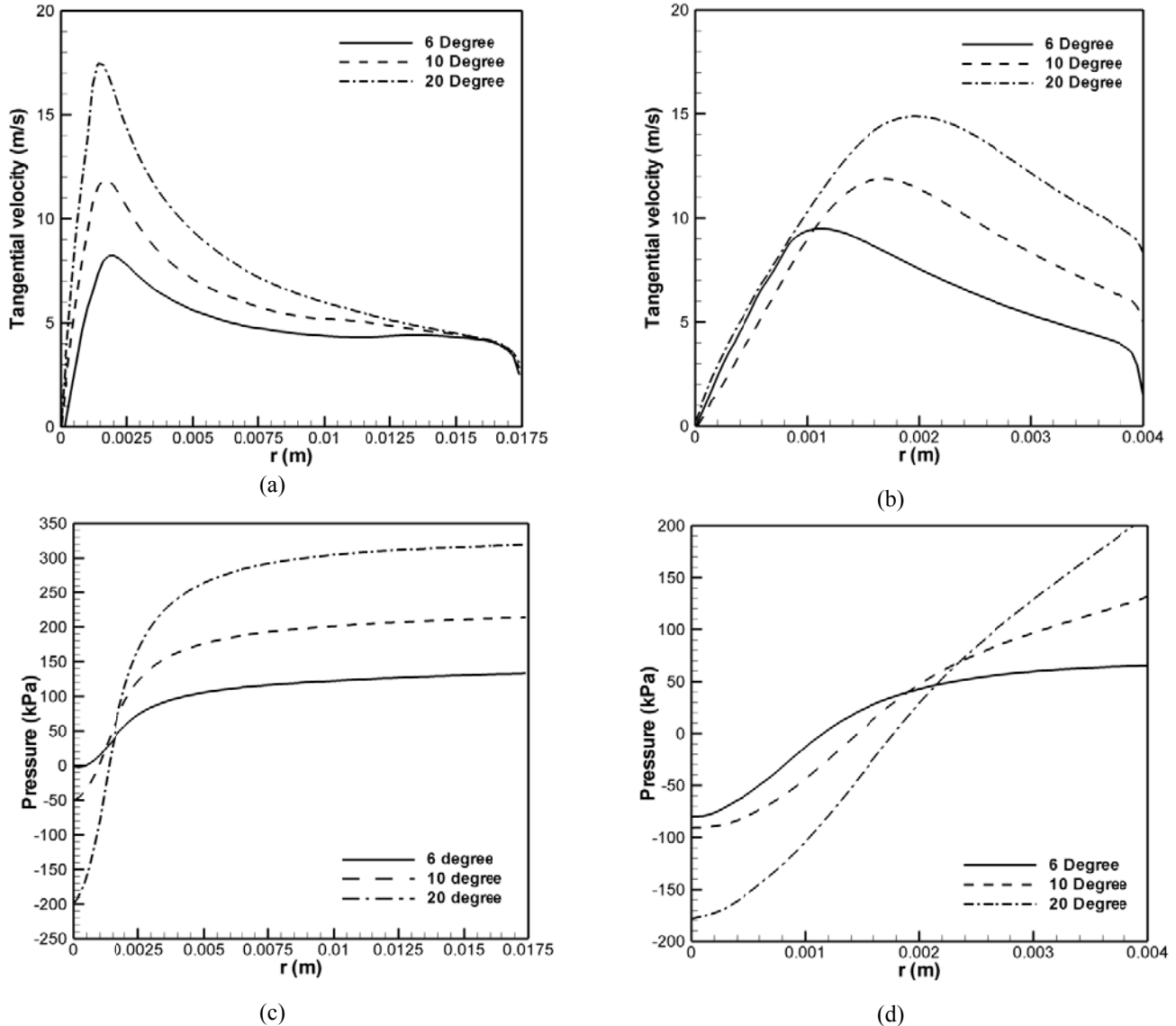

Fig. 5 Tangential velocity versus radial position at a) top, b) bottom of cone section Pressure distribution versus radial position at c) top, d) bottom of cone section

## VI. CONCLUSION

Velocity and pressure distribution inside deoiling hydrocyclones are obtained by using Large Eddy Simulation for three different cone angles. Tangential velocity magnitude increases with cone angle. More sharpness in forced vortex section is seen in higher cone angles especially in upper positions.

The pressure gradient toward radial position is increased with cone angle and has a positive effect on separation but it should be noted that in large cone angle hydrocyclones separation time is decreased due to larger velocities and smaller cone height.

## REFERENCES

- [1] A. Belaidi, M. T. Thew, S. J. Munaweera, "Hydrocyclone performance with complex oil-water emulsions in the feed", *Can. J. Chem. Eng.*, 81, 2003, pp. 1159-1170.
- [2] C. Gomez, J. Caldenty, S. Wang, "Oil/water separation in liquid/liquid hydrocyclones: part I experimental investigation", *SPE J.* 7, 2002, pp. 353-372.
- [3] R. G. Devorak, "Separation of light dispersions in long hydrocyclones", Master of Science Thesis, Michigan State University, USA, 1989.
- [4] D. J. Simkin, R. B. Olney, "Phase Separation and Mass Transfer in a Liquid-Liquid Cyclone", *AIChE J.* 2, 1956, pp. 545-551.
- [5] H. P. Sheng, J. R. Welker, C. M. Shiepcovich, "Liquid-Liquid Separation in a Conventional Hydrocyclone", in *The Canadian J. of Chem. Eng.* 52, 1974, pp.487-491.
- [6] D. A. Colman, "The Hydrocyclone for Separating Light Dispersions", Ph.D. Thesis, Southampton University, UK, 1981.
- [7] D. Colman, M. Thew, D. Corney, "hydrocyclones for Oil/Water Separation", *Int. Conf. on Hydrocyclones*, BHRA, Cambridge, United Kingdom, 1980, pp. 143-165.
- [8] D. Colman, M. Thew, "Hydrocyclone to Give a Highly Concentrated Sample of a Lighter Dispersed Phase" *Int. Conf. on Hydrocyclones*, BHRA, Cambridge, United Kingdom, 1980, pp. 209-223.
- [9] D. Colman, M. Thew, "Correlation of Separation Results from Light Dispersion Hydrocyclones", in *Chem. Eng. Res. Des.* 61, 1983, pp. 233-240.
- [10] J. A. Delgadillo, R. K. Rajamani, "A comparative study of three turbulence closure models for the hydrocyclone problem", *Int. J. Miner. Process.* 77 (4), 2005, pp. 217-230.
- [11] J. A. Delgadillo, R. K. Rajamani, "Hydrocyclone modeling: large eddy simulation CFD approach", *Minerals and Metallurgical Processing* 22 (4), 2005, pp. 225-232.
- [12] J. A. Delgadillo, R. K. Rajamani, "Exploration of hydrocyclone designs using computational fluid dynamics", *Int. J. Miner. Process.* 84, 2007, pp. 252-261.
- [13] J. A. Delgadillo, R. K. Rajamani, "Large Eddy Simulation (LES) of Large Hydrocyclones", *Particulate Science and Technology* 25, 2007, pp. 227-245.
- [14] M. Saidi, R. Maddahian, B. Farhanieh, H. Afshin, "Modeling of flow field and separation efficiency of a deoiling hydrocyclone using large eddy simulation", *Int. J. Miner. Process.* 112-113, 2012, pp. 84-93.
- [15] S. Noroozi, S. H. Hashemabadi, "CFD Simulation of Inlet Design Effect on Deoiling Hydrocyclone Separation Efficiency", *Chem. Eng. Technol.* 32 (12), 2009, pp. 1885-1893.
- [16] S. Noroozi, S. H. Hashemabadi, "CFD analysis of inlet chamber body profile effects on de-oiling hydrocyclone efficiency", *Chem. Eng. Res. Des.* 89 (7), 2011, pp. 968-977.
- [17] J. Smagorinsky, "General circulation experiments with the primitive equations", *Month. Weather* 91, 1963, pp. 99-165.
- [18] P. Moin, J. Kim, "Numerical investigation of turbulent channel flow", *J. Fluid Mech.* 118, 1982, pp. 341-377.
- [19] W. Jones, M. Wille, "Large eddy simulation of a jet in a cross flow", in: *10<sup>th</sup> Symposium On Turbulent Shear Flows*, The Pennsylvania State University, 1995, pp. 41-46.
- [20] M. Germano, U. Piomelli, P. Moin, W. H. Cabot, "A dynamic subgrid-scale eddy viscosity model", *Phys. Fluids* 3(7), 1991, pp. 31760-31765.
- [21] D. K. Lilly, "A proposed modification of the Germano subgrid scale closure method", *Phys. Fluids* 4(3), 1992, pp. 633-635.
- [22] Z. Bai, H. Wang, S. Tu, "Experimental study of flow patterns in deoiling hydrocyclon", *Mineral Engineering* 22, 2009, pp. 319-323.
- [23] R.I. Issa, "Solution of the implicitly discretised fluid flow equations by operator-splitting", *J. Comput. Phys.* 62, 1986, pp. 40-65.