

Design of PI Controller Using MRAC Techniques For Couple-Tanks Process

Boonsrimuang P., Numsomran A. and Kangwanrat S.

Abstract—The typical coupled-tanks process that is TITO plant has the difficulty in controller design because changing of system dynamics and interacting of process. This paper presents design methodology of auto-adjustable PI controller using MRAC technique. The proposed method can adjust the controller parameters in response to changes in plant and disturbance real time by referring to the reference model that specifies properties of the desired control system.

Keywords—PI controller, MRAC, Couple-tanks process

I. INTRODUCTION

The control of liquid level in tanks and flow between tanks is a basic problem in the process industries. In vital industries such as Petro-chemical industries, Paper making industries, Water treatment industries have the coupled tanks processes of chemical or mixing treatment in the tanks, the level of fluid in the tanks and interacting between tanks must be controlled. It is essential for control system engineers to understand how coupled tanks control systems work and how the level control problem is solved. The problem of level control in coupled tanks processes are system dynamics and interacting characteristic. Many control methods such as 2-DOF PID [1], Auto tuning PID [2], CDM [3] and Decoupling [4] have been applied to coupled tanks processes for solving their problems.

This paper presents design methodology of auto-adjustable PI controller using MRAC technique for solving the problem of coupled tanks processes. The proposed method can adjust the controller parameters in response to changes in plant and disturbance real time by referring to the reference model that specifies properties of the desired control system. Therefore, this technique is convenient for controller design under the requirement of the system.

The paper is organized as follows. The next section gives details about Coupled-tank process. Section 3 explains a MRAC technique. Section 4 explains an implementation of PI

Boonsrimuang P. is with the Faculty of Engineering, Telecommunications Engineering, King Mongkut's Institute of Technology Ladkrabang, Bangkok, Thailand.

Numsomran A. is with the Faculty of Engineering, Instrumentation Engineering, King Mongkut's Institute of Technology Ladkrabang, Bangkok, Thailand., Phone: 661-9250356; Email: knarjin@kmitl.ac.th

Kangwanrat S. is with the Faculty of Engineering, Instrumentation Engineering, King Mongkut's Institute of Technology Ladkrabang, Bangkok, Thailand.

Controller using MRAC Technique for coupled tank process. Section 5 shows experiment process and results. Finally, conclusions are given in section 6.

II. COUPLED-TANK PROCESS

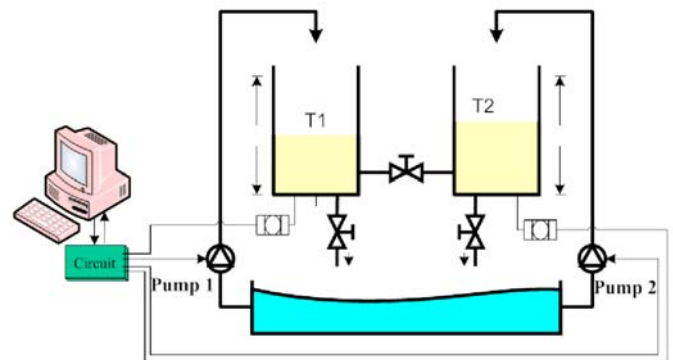

Fig.1 The Schematic of Coupled-Tank Process.

Consider the coupled-tank , two-input two-output process, in fig.1. The target is to control water level of lower two tanks $h_1(t)$, $h_2(t)$ by the inlet water flow from two pumps $Q_1(t)$, $Q_2(t)$. The process inputs are input voltage of two pumps $u_1(t)$, $u_2(t)$. The balance of water level in two tanks relates with inlet flow $Q_1(t)$, $Q_2(t)$, outlet valve ratio β_1, β_2 and connected valve ratio β_x that acts on interacting between two tanks.

The nonlinear plant equations can be obtained by mass balance equation and Bernoulli's law. After linearization process, we obtain the linearized plant equations as (1).

$$\begin{aligned} \frac{dh_1(t)}{dt} &= \frac{k_1}{A} U_1(t) - \frac{\beta_1 a}{A} \sqrt{\frac{g}{2h_1}} H_1(t) \\ &\quad + \frac{\beta_x a}{A} \sqrt{\frac{g}{2|h_2 - \bar{h}_1|}} [H_2(t) - H_1(t)] \\ \frac{dh_2(t)}{dt} &= \frac{k_2}{A} U_2(t) - \frac{\beta_2 a}{A} \sqrt{\frac{g}{2h_2}} H_2(t) \\ &\quad - \frac{\beta_x a}{A} \sqrt{\frac{g}{2|h_2 - \bar{h}_1|}} [H_2(t) - H_1(t)] \end{aligned} \quad (1)$$

Where A is the cross section area of tank 1 and tank 2 (cm^2), a is the cross section area of outlet hole of tank 1, tank 2 and cross section area of jointed pipe between tank 1 and tank 2 (cm^2), β_1 is the valve ratio at the outlet of tank 1, β_2 is the valve ratio at the outlet of tank 2, β_x is the valve ratio between tank 1 and tank 2, \bar{h}_1, \bar{h}_2 are the steady-state water level of tank 1 and tank 2, g is the gravity (cm^2/s) and k_1, k_2 are the gain of pump 1 and pump 2 ($cm^3/V \cdot s$).

From the linearized plant equations (1) can be transformed to the equation as (2)

$$\begin{bmatrix} h_1(s) \\ h_2(s) \end{bmatrix} = \begin{bmatrix} G_{11}(s) & G_{12}(s) \\ G_{21}(s) & G_{22}(s) \end{bmatrix} \begin{bmatrix} u_1(s) \\ u_2(s) \end{bmatrix} \quad (2)$$

Where transfer matrix $G_{ij}(s)$ has the value as following

$$G_{11}(s) = \frac{\frac{k_1}{A} \left(s + \frac{(T_x + T_2)}{T_2 T_x} \right)}{s^2 + \left(\frac{T_1 T_x + T_2 T_x + 2T_1 T_2}{T_1 T_2 T_x} \right) s + \left(\frac{1}{T_1 T_2} + \frac{1}{T_1 T_x} + \frac{1}{T_2 T_x} \right)}$$

$$G_{12}(s) = \frac{\frac{k_2}{A} \cdot \frac{1}{T_x}}{s^2 + \left(\frac{T_1 T_x + T_2 T_x + 2T_1 T_2}{T_1 T_2 T_x} \right) s + \left(\frac{1}{T_1 T_2} + \frac{1}{T_1 T_x} + \frac{1}{T_2 T_x} \right)}$$

$$G_{21}(s) = \frac{\frac{k_1}{A} \cdot \frac{1}{T_x}}{s^2 + \left(\frac{T_1 T_x + T_2 T_x + 2T_1 T_2}{T_1 T_2 T_x} \right) s + \left(\frac{1}{T_1 T_2} + \frac{1}{T_1 T_x} + \frac{1}{T_2 T_x} \right)}$$

$$G_{22}(s) = \frac{\frac{k_2}{A} \left(s + \frac{(T_x + T_1)}{T_1 T_x} \right)}{s^2 + \left(\frac{T_1 T_x + T_2 T_x + 2T_1 T_2}{T_1 T_2 T_x} \right) s + \left(\frac{1}{T_1 T_2} + \frac{1}{T_1 T_x} + \frac{1}{T_2 T_x} \right)}$$

where

$$T_1 = \frac{A}{\beta_1 a} \sqrt{\frac{2\bar{h}_1}{g}}, \quad T_2 = \frac{A}{\beta_2 a} \sqrt{\frac{2\bar{h}_2}{g}}, \quad T_x = \frac{A}{\beta_x a} \sqrt{\frac{2|\bar{h}_1 - \bar{h}_2|}{g}}$$

\bar{h}_1, \bar{h}_2 are the steady-state water level of tank 1 and tank 2, T_1 is the time constant of tank 1, T_2 is the time constant of tank 2 and T_x is the time constant between tank 1 and tank 2.

III. MRAC

The block diagram in Fig. 2 shows the structure of a model-reference adaptive control (MRAC) system that composed of

process, controller, reference model and adjustment mechanism block

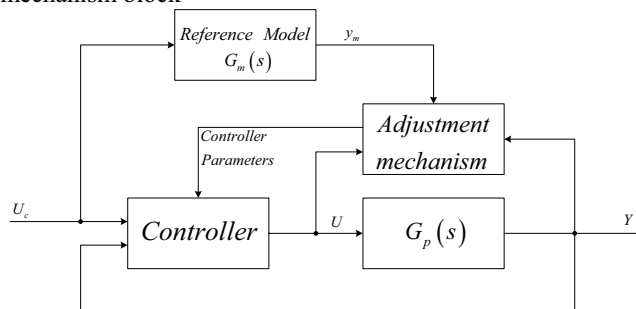

Fig. 2 Block diagram of a model-reference adaptive control (MRAC) system.

The model reference adaptive control (MRAC) Technique is based on information y_m, y, u and u_c that is used for devising a controller. The adjustment mechanism automatically adjusts controller parameters so that the behavior of the closed-loop control plant output (y) closely follows that (y_m) of the reference model. Parameters and structure of reference model are specificities on base of requirements of control performance.

The adjustment mechanism of MRAC system constructs by adaptive control rule, called MIT rule which performs the algorithms as following.

Tracking error

$$e = y_p - y_m \quad (5)$$

Form cost function

$$J(\theta) = \frac{1}{2} e^2(\theta) \quad (6)$$

MIT Rule says that the time rate of change of θ is proportional to negative gradient of J . That is

$$\frac{d\theta}{dt} = -\gamma \frac{\partial J}{\partial \theta} = -\gamma e \frac{\partial e}{\partial \theta} \quad (7)$$

Where e denotes the model error and θ is the controller parameter vector. The components of $\frac{\partial e}{\partial \theta}$ are the sensitivity

derivatives of the error with respect to θ . The parameter γ is known as the adaptation gain. The MIT rule is a gradient scheme that aims to minimize the squared model cost function [5].

IV. USE PI CONTROLLER USING MRAC TECHNIQUE FOR COUPLE-TANK PROCESS

Because of the interaction between processes, the Couple-tank control system needs the decoupling controllers to minimize the cross coupling effects. After the decoupling design, [4] we get 2 SISO transfer functions of plant g_{n11} and g_{n22} which are used for PI controller design by MRAC technique respectively.

Consider a system described by 1st order model $b/(a_0s + a_1)$. A block diagram of control system depicts in Fig. 3.

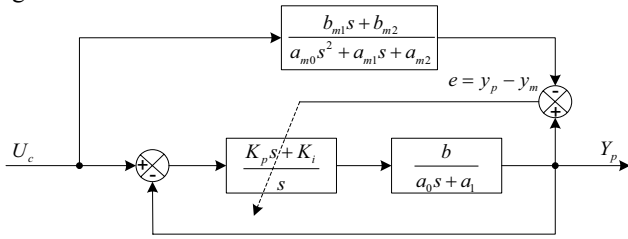

Fig. 3 structure of 1st order MRAC control system

So that closed loop transfer function

$$\frac{Y_p(s)}{U_c(s)} = \frac{b(K_p s + K_i)}{a_0 s^2 + (a_1 + bK_d)s + bK_i} \quad (7)$$

and

$$Y_p(s) = \frac{b(K_p s + K_i)}{a_0 s^2 + (a_1 + bK_d)s + bK_i} \cdot U_c(s) \quad (8)$$

From (7) and required performance of system, we obtain a reference model as (9).

$$\frac{Y_m(s)}{U_m(s)} = \frac{b_{m1}s + b_{m2}}{a_{m0}s^2 + a_{m1}s + a_{m2}} \quad (9)$$

Apply MIT gradient rules for determining the value of PI controller parameters K_p, K_i in (10).

$$\frac{dK_p}{dt} = -\gamma_p \frac{\partial J}{\partial K_p} = -\gamma_p \left(\frac{\partial J}{\partial \varepsilon} \right) \left(\frac{\partial \varepsilon}{\partial y} \right) \left(\frac{\partial y}{\partial K_p} \right) \quad (10)$$

$$\frac{dK_i}{dt} = -\gamma_i \frac{\partial J}{\partial K_i} = -\gamma_i \left(\frac{\partial J}{\partial \varepsilon} \right) \left(\frac{\partial \varepsilon}{\partial y} \right) \left(\frac{\partial y}{\partial K_i} \right)$$

Where $\partial J/\partial \varepsilon = \varepsilon$, $\partial \varepsilon/\partial y = 1$

$$\frac{\partial Y_p}{\partial K_p} = \frac{bs}{a_0 s^2 + (a_1 + bK_d)s + bK_i} \cdot [-Y_p] \quad (11)$$

$$\frac{\partial Y_p}{\partial K_i} = \frac{b}{a_0 s^2 + (a_1 + bK_d)s + bK_i} \cdot [U_c - Y_p] \quad (12)$$

From (11), (12), it obtained $\frac{\partial K_p}{\partial t}, \frac{\partial K_i}{\partial t}$ as equation (13).

$$\frac{dK_p}{dt} = -\gamma_p \frac{\partial J}{\partial K_p} = -\gamma_p \varepsilon \frac{bs}{a_0 s^2 + (a_1 + bK_d)s + bK_i} \cdot [-Y_p] \quad (13)$$

$$\frac{dK_i}{dt} = -\gamma_i \frac{\partial J}{\partial K_i} = -\gamma_i \varepsilon \frac{b}{a_0 s^2 + (a_1 + bK_d)s + bK_i} \cdot [U_c - Y_p]$$

A block diagram in Fig. 4 shows how MRAC technique is implemented.

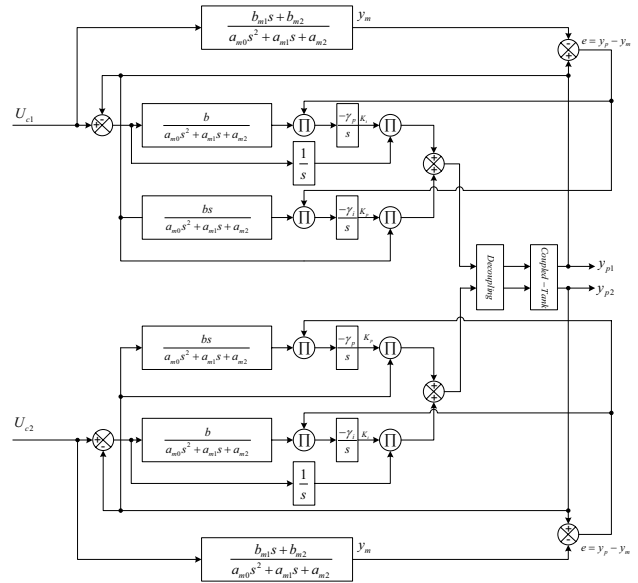

Fig. 4 MRAC Block Diagram for Couple-Tank Process

V. EXPERIMENT & RESULTS

Referring to the parameters and the operating points of process in table 1 and table 2, this process can be placed into the equation (1). It will be obtained the plant transfer function as in equation (14).

TABLE I
Process Parameters

Symbol	Description	Quantity
$A(cm^2)$	Cross section area of tank 1,2	66.25
$a(cm^2)$	Cross section area of outlet hole of tank 1,2	0.1963
β_1	Valve ratio at the outlet of tank 1	0.9015
β_2	Valve ratio at the outlet of tank 2	0.9919
β_x	Valve ratio between tank 1 and tank 2	0.9279

TABLE II
The operating point of process

Symbol	Description	Quantity
$u_1, u_2(V)$	Input voltage of pump 1,2	2.5, 2
\bar{h}_1	Water level of tank 1	5.25
\bar{h}_2	Water level of tank 2	2.45
$k_1(cm^3/V \cdot s)$	Gain of pump 1	5.4
$k_2(cm^3/V \cdot s)$	Gain of pump 2	4.8

$$\begin{bmatrix} G_{11}(s) & G_{12}(s) \\ G_{21}(s) & G_{22}(s) \end{bmatrix} = \begin{bmatrix} \frac{0.08151s + 0.006356}{(s^2 + 0.1402s + 0.003526)} & \frac{2.637 \times 10^{-3}}{(s^2 + 0.1402s + 0.003526)} \\ \frac{2.966 \times 10^{-3}}{(s^2 + 0.1402s + 0.003526)} & \frac{0.07245s + 0.004507}{(s^2 + 0.1402s + 0.003526)} \end{bmatrix} \quad (14)$$

From (14) we designed decoupling controllers $D_{12}(s)$ and $D_{21}(s)$ for decoupling the interaction in couple-tank process as equation (15), (16).

$$\begin{aligned} D_{12}(s) &= -\frac{G_{12}(s)}{G_{11}(s)} \\ &= -\left(\frac{2.637 \times 10^{-4}}{(s^2 + 0.1402s + 0.003526)} \times \frac{(s^2 + 0.1402s + 0.003526)}{0.08151s + 0.006356} \right) \\ &= -\frac{2.637 \times 10^{-4}}{0.08151s + 0.006356} \end{aligned} \quad (15)$$

$$\begin{aligned} D_{21}(s) &= -\frac{G_{21}(s)}{G_{22}(s)} \\ &= -\left(\frac{2.966 \times 10^{-4}}{(s^2 + 0.1402s + 0.003526)} \times \frac{(s^2 + 0.1402s + 0.003526)}{0.07245s + 0.004507} \right) \\ &= -\frac{2.966 \times 10^{-4}}{0.07245s + 0.004507} \end{aligned} \quad (16)$$

From decoupling controllers, it obtained new plant transfer functions as equation (17)

$$G_n(s) = \begin{bmatrix} G_{n11} & 0 \\ 0 & G_{n22} \end{bmatrix} \quad (17)$$

where

$$\begin{aligned} G_{n11}(s) &= G_{11}(s) - \frac{G_{21}(s)}{G_{22}(s)} G_{12}(s) = G_{11}(s) - D_{21}(s) G_{12}(s) \\ &= \frac{0.08151}{s + 0.06221} \end{aligned} \quad (18)$$

$$\begin{aligned} G_{n22}(s) &= G_{22}(s) - \frac{G_{12}(s)}{G_{11}(s)} G_{21}(s) = G_{22}(s) - D_{12}(s) G_{21}(s) \\ &= \frac{0.07245}{s + 0.07797} \end{aligned} \quad (19)$$

A. Simulation of Tank1 Control Loop

Plant transfer function $G_p(s) = \frac{0.08151}{s + 0.06221}$

Design PI controllers by using MRAC Technique as the control structure in Fig.2.

From the specifies properties of the desired control system $P.O.=10\%$ and $t_s=150$, a reference model is shown in (20)

$$\frac{Y_m(s)}{U_m(s)} = \frac{s + 0.0011}{s^2 + 0.04s + 0.0011} \quad (20)$$

B. Simulation of Tank2 Control Loop

Plant transfer function $G_p(s) = \frac{0.07245}{s + 0.07797}$

Design PI controllers by using MRAC Technique as the control structure in Fig.2.

From the specifies properties of the desired control system $P.O.=10\%$ and $t_s=100$, a reference model is shown in (21)

$$\frac{Y_m(s)}{U_m(s)} = \frac{s + 0.0026}{s^2 + 0.06s + 0.0026} \quad (21)$$

The test done by control the response of tank1 and tank2 control system ($g_{n11}(s), g_{n22}(s)$) at the set-point as the details in table 3.

TABLE II
The operating point of process

Tank	$t=0s$	$t=1500s$	$t=3000s$	$t=4500s$
1	2	-	4	-
2	2	4	-	-

Determining the value of PI controller parameters K_p, K_i by MRAC algorithm, we defined the value of adaptation gain γ as following

Tank1 $\gamma_p = -0.01$ and $\gamma_i = -0.00003$ (17)

Tank2 $\gamma_p = -0.01$ and $\gamma_i = -0.00005$

The simulation results are shown as Fig.5-Fig.9 .

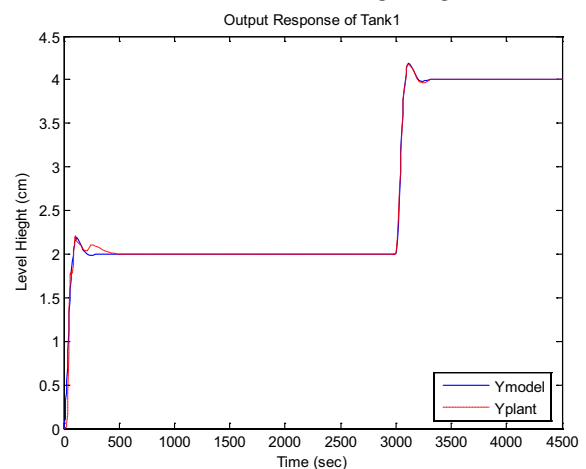

Fig.5 Comparison between output response y_p and y_m of Tank1 Control Loop.

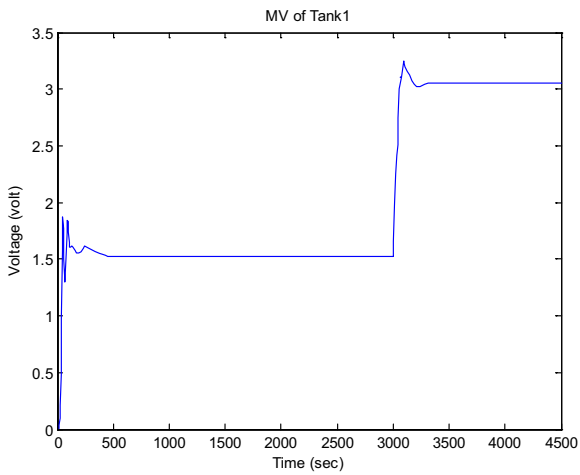

Fig.6 MV from PI Controller of Tank1 Control Loop

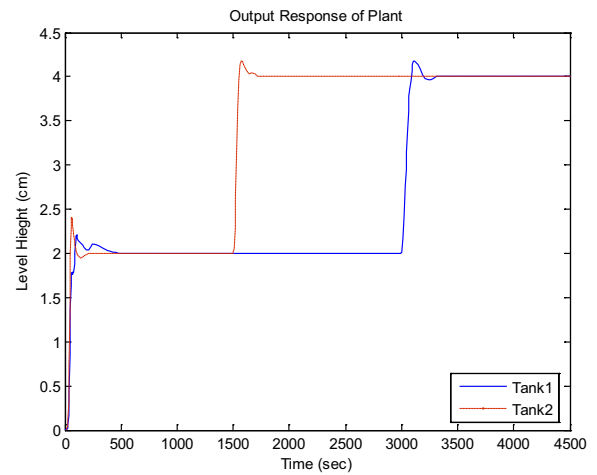

Fig.9 Simulation Output response y_{p1} y_{p2} of MRAC Control System for Coupled-Tank Process

The experiment results are shown as Fig.10-Fig.14 .

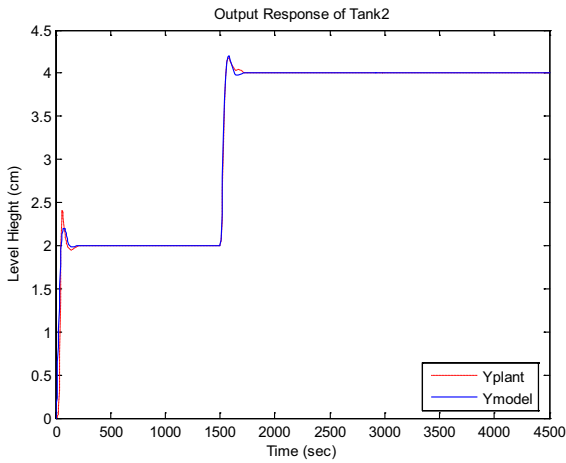

Fig.7 Comparison between output response y_p and y_m of Tank2

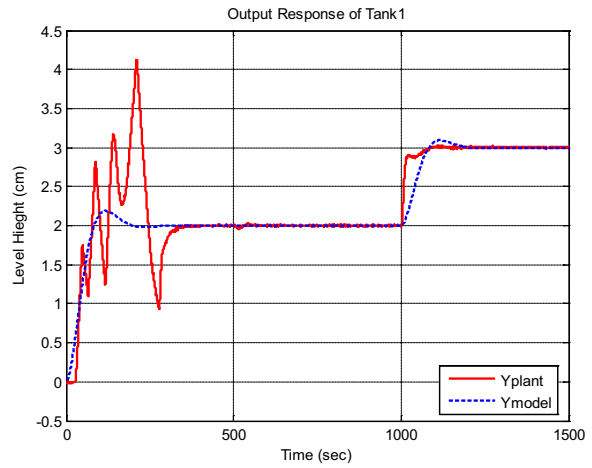

Fig.10 Comparison between output response y_p and y_m of Tank1

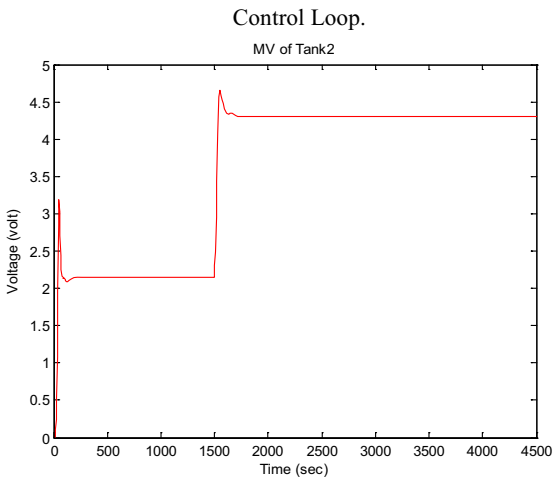

Fig.8 MV from PI Controller of Tank2 Control Loop

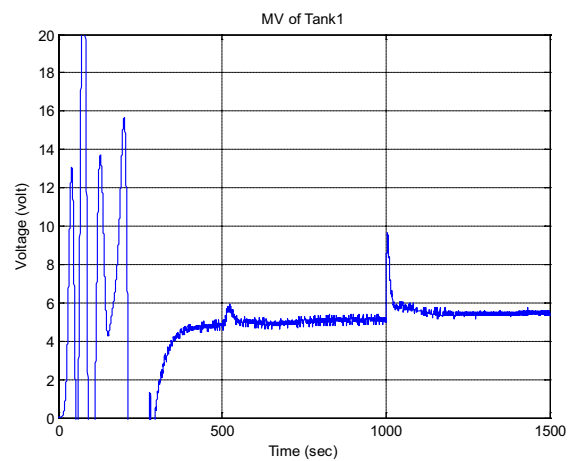

Fig.11 MV from PI Controller of Tank1 Control Loop

VI. CONCLUSION

The design of PI controller using MRAC techniques for couple-tanks process can adjust controller parameters in response to changes in plant and disturbance and with specifies properties of the desired control system. It is shown by the experiment results in Section 5 that MRAC technique solve the dynamic problem of the couple-tanks process and it is convenient for controller design under the requirement of the system.

REFERENCES

- [1] Astrom K.J., and T. Hagglund (1995). "PID Controllers: Theory, Design, and Tuning. Instrument." Society of America, 2nd edition.
- [2] Q.C. Wang, B. Zou, T.H. Lee and Q. Bi "Auto tuning of multivariable PID controllers from decentralized relay feedback", Automatica, Vol.33, No.3, pp. 319-330, 1997
- [3] Damir Vrancic, "Tuning of Decoupling Controller by using MIMO Method"
- [4] J.M. Maciejowski, *Multivariable Feedback Design*, Addison-Wesley, 1989
- [5] M. Zhuang, and D.P. Atherton, "PID controller design for a TITO system", IEE Proc.- Control Theory Appl., Vol.141, No.2, pp.111-120, 1994
- [6] C.C. Ko, Ben M. Chen, Jianping Chen; Yuan Zhuang, Key Chen Tan, "Development of a web-based laboratory for control experiments on a coupled tank apparatus". IEEE Transactions on Education, vol. 44, No. 1, February 2001
- [7] S. Majhi, "SISO controller for TITO systems", presented at the Int. Conf. on Energy, Automation and information Tech., 2001
- [8] N.K. Paulsen, B.Kouvaritakis and M.Cannon. "Non-linear constrained predictive control applied to a coupled-tanks apparatus" IEE Proc.- Control Theory Appl., Vol. 148, No. 1, January 2001
- [9] S.E.Hamamci and M.Koksal."Robust Controller Design for TITO Processes with Coefficient Diagram Method" Proceedings of IEEE Conference on Vol.2, 23-25 June 2003 Page(s):1431 - 1436 vol.2
- [10] Astrom, K.J. and B. Witten mark. "Computer Controlled Systems - Theory and Design" 1990, Prentice-Hall
- [11] Application Examples of the KRi Coupled-Tank Apparatus Model PP-100, Application Note Ref: CT-101. November 1, 1995

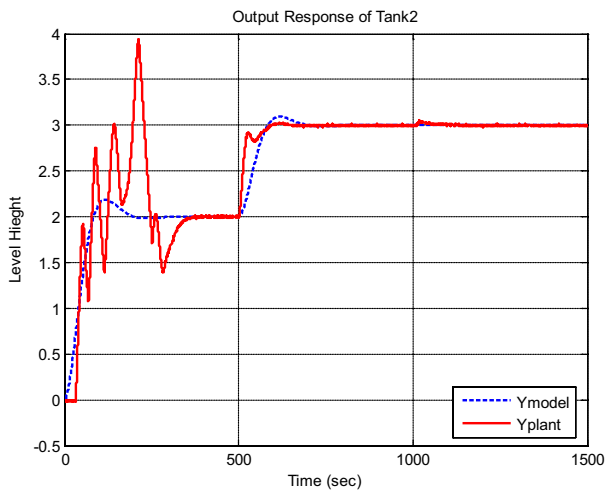

Fig.12 Comparison between output response y_p and y_m of Tank2

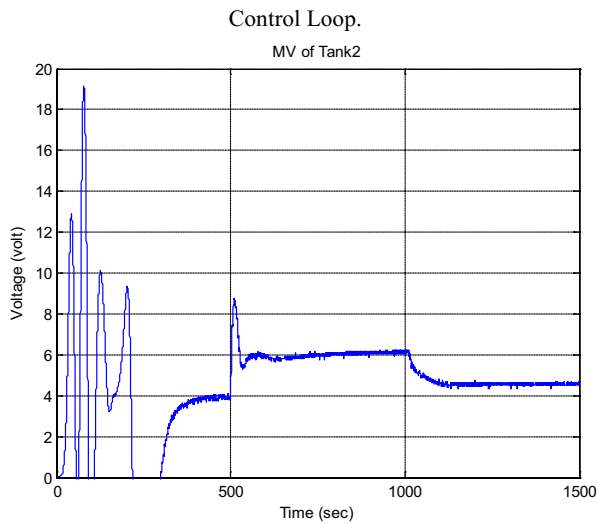

Fig.13 MV from PI Controller of Tank2 Control Loop

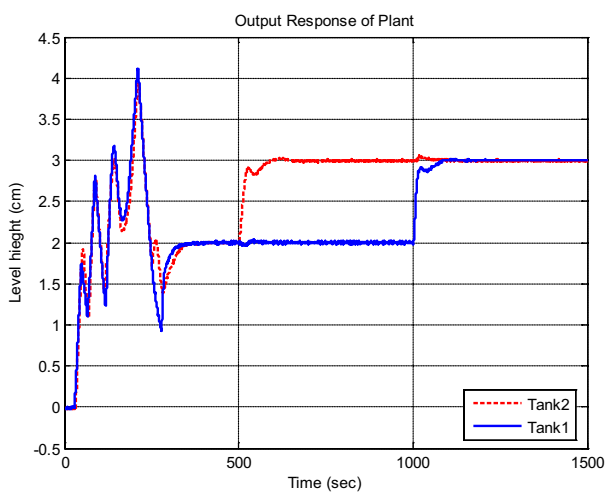

Fig.14 Response of MRAC PI Control System for Coupled-Tank Process