

# Analysis of Polymer Surface Modifications due to Discharges Initiated by Water Droplets under High Electric Fields

Michael G. Danikas, Ramanujam Sarathi, Pavlos Ramnalis, and Stefanos L. Nalmpantis

**Abstract**—This paper investigates the influence of various parameters on the behaviour of water droplets on polymeric surfaces under high electric fields. An inclined plane test was carried out to understand the droplet behaviour in strong electric field. Parameters such as water droplet conductivity, droplet volume, polymeric surface roughness and droplet positioning with respect to the electrodes were studied. The flashover voltage is affected by all aforementioned parameters. The droplet positioning is in some cases more vital than the droplet volume. Surface damages were analysed using Scanning Electron Microscopy (SEM) studies and by Energy dispersive X-ray Analysis (EDAX). It is observed that magnitude of discharge have direct influence on amount of surface damage.

**Keywords**—Water droplet, polymeric surface, hydrophobicity, partial discharges, SEM, EDAX.

## I. INTRODUCTION

POWER transmission at high voltages has acquired considerable prominence in the recent times. It has become essential to design and develop compact cost-effective and reliable insulation structures. With the advancement in polymer technology it has become possible to design insulation structures with the enhanced mechanical, electrical and thermal properties. In recent times, composite insulation materials are gaining importance as outdoor insulating structures especially the silicone rubber. Silicone rubber has good pollution performance and high hydrophobicity. In addition, it has high discharge resistance. One of the major problems in outdoor insulation structures is the degradation of the material due to corona. This corona can be from any sharp protrusion/water droplets. Water droplets on a polymeric surface increase locally the applied electric field. Local field intensifications lead to partial discharges (PD) and/or localized arcs, causing damage to insulating materials [1 - 4]. Having known all this, in the present study water droplet initiated discharges was studied on silicone rubber insulation adopting an inclined plane arrangement. The factors which can influence the discharges include conductivity of droplet,

volume of the droplet, position of the droplet in the electrode gap, droplet arrangement, polymer surface roughness etc. The influence of these parameters on the flashover of electrode gap initiated by water droplets is studied in detail. For the purpose of comparison and to understand the advantageous characteristics of silicone rubber, the PVC and rubber materials were also studied. It is equally important to understand the characteristic variation that occurs on the surface of the insulating material causing damage due to corona/PD's. Hence physico-chemical diagnostics studies viz. SEM and EDAX analysis were carried out as a part of the present work.

In the present work, a study of the aforementioned parameters on the water droplet behaviour under the influence of a uniform electric field in the range of  $1.7 \mu\text{S}/\text{cm} - 2000 \mu\text{S}/\text{cm}$  was carried out. All tests were performed with an inclined test arrangement, in order to simulate the behavior of water droplets on the surface of an outdoor insulator. The angle used with respect to the horizontal was  $10^\circ$ . Such an angle was chosen because of its immediacy to outdoor insulators.

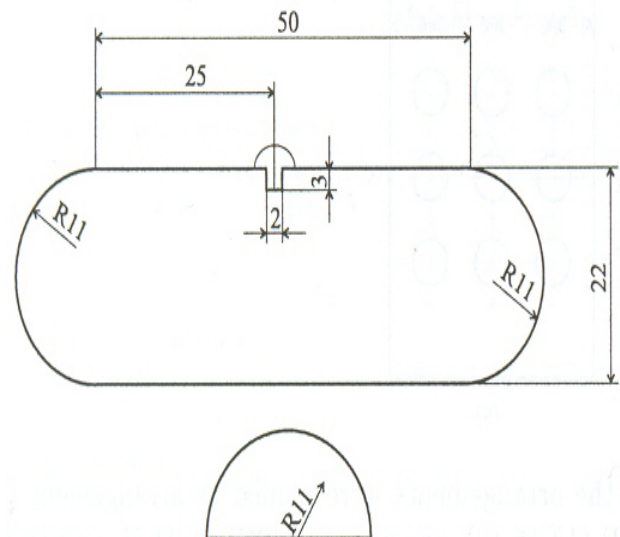

Fig. 1 Top view (above) and cross section (bottom) of the electrodes used (all dimensions in mm)

## II. EXPERIMENTAL STUDIES

The high AC voltage was generated using a 20 kV transformer (in practice the transformer may deliver voltages up to 1.2 times of its nominal voltage without loss of the

Michael G. Danikas is with Department of Electrical and Computer Engineering, Democritus University of Thrace, Xanthi, Greece. Corresponding author is now visiting scholar with Waseda University, Kitakyushu, Japan (e-mail: mdanikas@ee.duth.gr).

Ramanujam Sarathi is with Department of Electrical Engineering, IIT Madras, Chennai- 600 036, India and he is now Visiting Researcher with Waseda University, Kitakyushu, Japan.

accuracy of the measurement. Consequently, the applied voltages were accurate up to 24 kV. The top view as well as a cross section of an electrode (used in the present study) with its dimensions is as shown in Fig. 1. The electrodes were half cylindrical in shape and of copper material. Much attention was paid to the smoothness of the electrode surfaces, so that no field enhancements could be noticed in the operating zone.

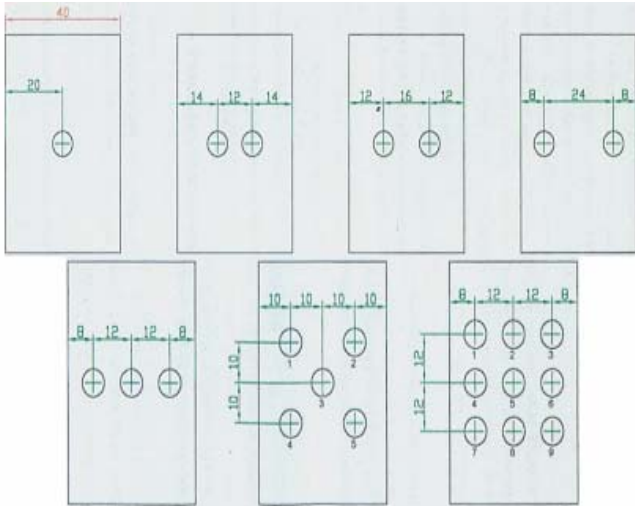

Fig. 2 Top view showing the droplet arrangements. Starting from top left, (1) (with one droplet), arrangement (2a) (with two droplets, 14-12-14), arrangement (2b) (with two droplets, 12-16-12), arrangement (2c) (two droplets, 8-24-8), arrangement (3) (with 3 droplets), arrangement (5) (with 5 droplets) and arrangement (9) (with 9 droplets). dimensions are in mm and they symbolize the distances of the droplets from the respective electrodes and between them.

The water droplets were positioned on the polymeric material surface with the aid of a special arrangement consisting of a metallic frame and three rules, one of which had two laser indicators. The water droplets were put on the surface with a 10 ml syringe. Detailed information on the way the droplets were positioned on the polymeric surface is given in Fig. 2. The polymeric materials used were PVC, rubber and silicone rubber. Surface roughness and resistivity of the material were also measured. Surface roughness was measured using perthometer (Type Perthometer M4P) and the surface roughness was 0.25  $\mu\text{m}$  for PVC, 0.79  $\mu\text{m}$  for silicone rubber and 1.10  $\mu\text{m}$  for rubber. Resistivity of the material were measured using with a Megger (BM25 type) and they gave a resistivity of 206 G $\Omega$  for PVC, a resistivity of 3100 G $\Omega$  silicone rubber and a resistivity of 2660 G $\Omega$  for rubber. The above values of surface roughness and surface resistivity were not isolated values, but each of them was the mean of three measurements made at different locations at the surface of the material. The Scanning Electron Microscope (SEM) (type JEOL JSM-6390 LV), was used together with an EDAX analysis for the analysis of surface condition of the damage due to water droplet formed partial discharge/corona activity/arcing.

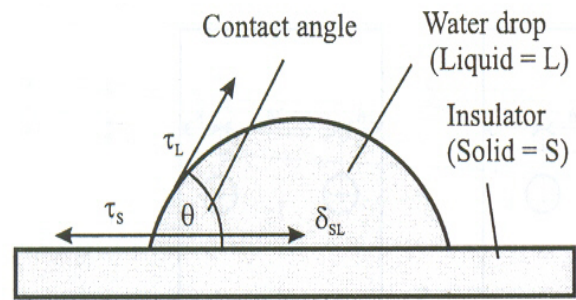

Fig. 3 Force balance at the interface solid/liquid at a water droplet on an insulating surface

In the present study, to understand corona initiated surface breakdown on silicone rubber material inclined plane tests were carried out. The angle of inclination maintained at 10 degrees simulating the angle observed in outdoor insulators. In the present work, water droplets with different conductivities obtained by mixing known quantity of NaCl in distilled water forming solutions with conductivity in the range 1.7  $\mu\text{S}/\text{cm}$  to 2000  $\mu\text{S}/\text{cm}$ . The conductivity of the water was measured using an AQUALYTIC digimeter L 21 with a probe. The range of conductivities were chosen based on the conductivity of natural rain and its values lie in the range 50 - 150  $\mu\text{S}/\text{cm}$ , whereas the routine tests with porcelain and glass insulators are performed with conductivities of 2500  $\mu\text{S}/\text{cm}$  [5]. The current measurements were carried out by connecting small resistance of about 1 kohms in series with the ground electrode. The potential across the resistance were directly fed to the oscilloscope (Agilent 4 channel, 100 MHz digital storage oscilloscope) for the shape and instant of occurrence of discharges.

### III. FORCE BALANCE DYNAMICS AT INTERFACE OF THE WATER DROPLET AND POLYMER

A modeling of a wet contaminated surface was given in other publications and only a brief outline is provided here [6]. In Fig. 3, the forces exercised on the droplet are shown in case where no electrical field is applied. Such forces are the surface tension of the liquid ( $\tau_L$ ), the surface tension of the solid ( $\tau_s$ ) and the interfacial tension between liquid and solid ( $\delta_{SL}$ ). When an electric field is applied, the droplet deforms because of an additional force forming a lotus effect. In the present study the contact angle of silicone rubber was measured using sessile droplet technique and its value is about 110 degrees. The tangential electric field on the surface of the insulator creates a force on the surface of the droplet which causes its deformation. The deformation of the droplet affects the field distribution. Local field intensifications may result, which will cause micro-discharges between the droplets. This is the indication of the chemical deterioration of the insulator surface causing reduction in hydrophobicity. Since the droplet forms lotus effect, corona discharge initiates from the edge of the droplet causing multiple droplets. It is also observed that the discharge normally initiates from the high voltage

electrode and the water droplet edge followed with arcing leading to flashover.

The voltage difference across the droplet will be diminished and micro-discharges will follow. Solvable nitrates, which are the result of the electrochemical deterioration, cause a higher conductivity of the water droplets. Dry zones may follow. It is important to bear in mind that not only the influence of the applied electric field on the shape of the droplet is of great significance, but also the influence of the disintegrated droplet on the electric field distribution [6, 7].

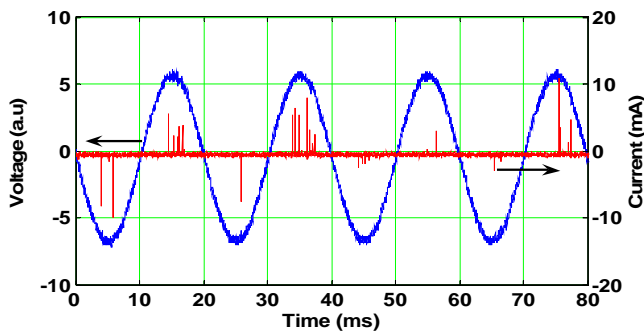

Fig. 4 Typical Voltage and current measured at the time of corona inception from water droplet

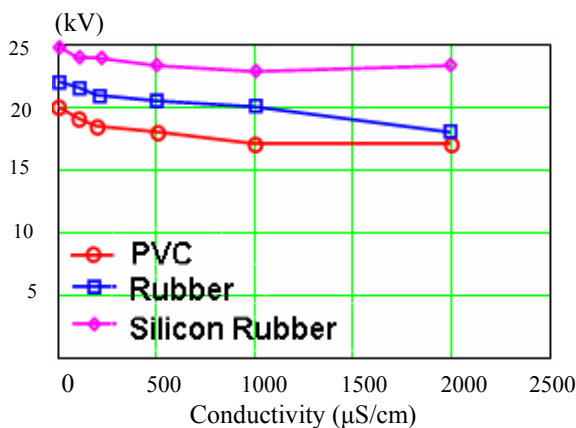

Fig. 5 Flashover voltage for various conductivities. 1 – PVC, 2 – rubber, 3 – silicone Rubber. Droplet arrangement (1)

Hydrophobic polymeric surfaces are characterized by a low surface conductivity which in turn gives a low discharge activity and a higher flashover voltage. This holds also for polluted environments. Reduced hydrophobicity implies a higher risk for flashover of the insulator. Hydrophilic materials, on the other hand, are very sensitive to polluted environments, and are characterized by a significant activity of local discharges [8].

#### IV. EXPERIMENTAL METHODOLOGY

The materials used in the present study were PVC, silicone rubber and rubber. Various droplet arrangements were studied. These arrangements are given in Fig. 2. Each droplet had a volume of 0.2 ml. The electrodes were positioned at a

distance of 4 cm from each other. The parameters investigated were the influence of water conductivity, the roughness of the insulating surface, the positioning of the droplets and their volume on the discharge activity. The insulating surfaces were used as they were received from the manufacturer without any further treatment. After placing the droplets on the polymeric surface, the voltage was slowly raised up to the point of flashover. Then the surface of the insulating material cleaned using ethanol and a new set of droplets were placed on the surface of insulation and then energized to a voltage level of flashover. If no flashover occurred, the voltage was raised by 0.4 kV and the procedure was repeated until flashover occurred. The reason we left every time the voltage ON for 1 min, was in order to give necessary time interval for the droplet(s) to deform and for the partial discharge to initiate.

It should be noted a tendency for the droplets to slide, especially for PVC because of its smooth surface. The droplet slide was minimal in the case of rubber, with the rougher surface. A more evident oscillation of the droplet was observed with silicone rubber. The reason for that was because the aforementioned material is more hydrophobic than the other two. Consequently, the droplet, for a defined droplet volume, has a smaller contact area with silicone rubber, and for this reason it oscillates more. In some cases, such as with PVC with a droplet conductivity of 1.7 μS/cm and with the arrangement (1) of Fig. 2, ejection of minute charged droplets was observed just before flashover [9].

#### V. RESULTS AND DISCUSSION

At first, experiments were performed without any droplets between the electrodes. This was done in order to have reference values of the flashover voltage and also to understand the influence of number of droplets between the electrodes would result in a reduction of the flashover voltage. The flashover voltages without any droplets measured were 23 kV (± 0.5) for PVC, 25 kV (± 0.5) for silicone rubber and 24 kV (± 0.5) for rubber. The surface flashover voltages of the three materials used were very similar. The causes for it are due to free electrons and ions formed in the medium than any other parameter.

In Fig. 4 a typical voltage and current measurement is given at the point of corona inception from a water droplet. Evidently the current pulses occur when the applied voltage attains the maximum value. In Figs. 5 - 8 the variation of flashover voltage with respect to the droplet conductivity for different droplet arrangements is shown. It is evident that silicone rubber presents a higher flashover voltage than the other two materials. It should be noted, however, that in the case of droplet arrangements (5) and (9) where rubber seems to be as good as silicone rubber. A possible explanation might be that in such a case, the droplets cover a significant part of the polymeric surface and hence they play an even more important role than the polymer itself. This in combination with the fact that the rubber has a rougher surface compared to the other two materials, has as a result the lesser oscillation in the case of rubber.

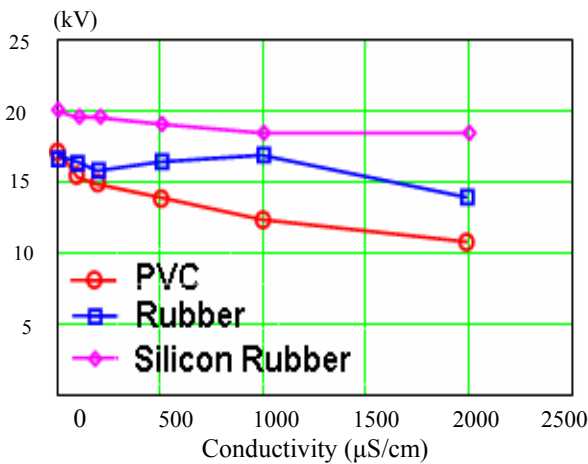

Fig. 6 Flashover voltage for various conductivities.  
 1 – PVC, 2 – rubber, 3 – silicone rubber. Droplet arrangement (2a)

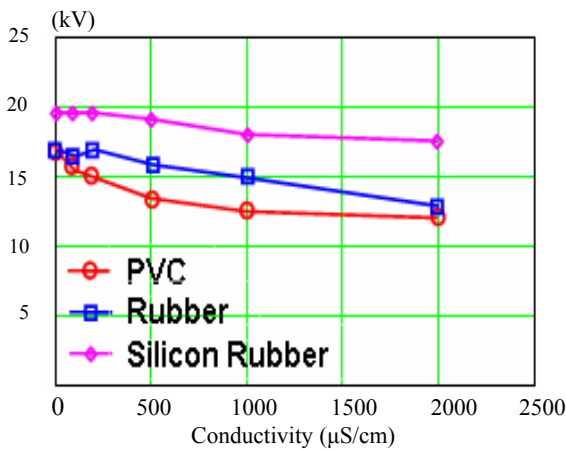

Fig. 7 Flashover voltage for various conductivities.  
 1 – PVC, 2 – rubber, 3 – silicone rubber. Droplet arrangement (2b)

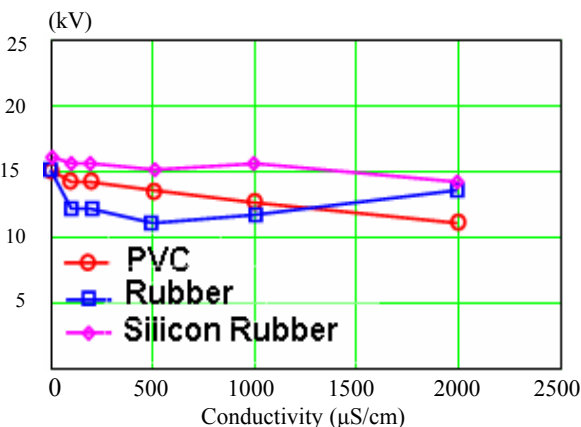

Fig. 8 Flashover voltage for various conductivities.  
 1 – PVC, 2 – rubber, 3 – silicone rubber. Droplet arrangement (2c)

An interesting case consist also the droplets arrangements 2a, 2b and 2c. Higher values for flashover voltage were observed for arrangement 2a, then for arrangement 2b and the

lower flashover voltage was observed for droplet arrangement 2c. This fact reinforces the above observations, namely that the positioning of the droplets play a crucial role, i.e. the closer the droplets to the electrodes, the lower the flashover voltage. It is to be noted that similar observations were made also in [3, 4], where not an inclined arrangement was used but a horizontal one. What is presented in this paper is an approach of the behavior of water droplets on polymeric surfaces with an inclined electrode arrangement. The results were reproducible but not that many tests were carried out which would allow a statistical study of the collected data. The main interest of this paper concentrates on the study of the behavior of the droplets. In the present context, no emphasis was given to the quantification of the studied parameters.

In this paper, some parameters influencing the droplet behaviour on polymeric surfaces were investigated, such as water conductivity, droplet volume, polymeric surface roughness and droplet positioning. An increase of conductivity causes a decrease of flashover voltage. This is a statement valid irrespective of the polymer used. The surface roughness affects in a positive way the flashover voltage, when the number of droplets is large. The surface roughness functions as a hindrance to the movement of the droplets, and consequently renders their oscillation more difficult. An increase of droplet volume causes a decrease of flashover voltage. This is in agreement with experimental observations published before with either ac or dc electric fields [10]. The position of the droplets with respect to the electrodes is of vital importance. With the droplets nearer the electrodes, the flashover voltage decreases. This is a phenomenon observed, albeit in different circumstances and conditions, also with enclosed cavities in solid dielectrics, where discharges become much more intense when one of the enclosing walls is an electrode [11].

The above show clearly that the polymeric material plays a predominant role in determining the flashover voltage and the behavior of water droplets and confirms that hydrophobic materials, such as silicone rubber, perform better than PVC or rubber. With this in mind, one should also note that most polymeric materials for outdoor applications present some sort of hydrophobicity. However, the advantage of silicone rubber consists in the fact that it does not only have this property, it can also regenerate it [12].

The forming of water paths, between the droplets as well as between the droplets and the electrodes, generally follow the direction of the applied electric field. The general activity in the form of discharges and droplet movement with rougher surfaces, sets in at higher voltages. In the case of just one droplet, with the application of the field, a deformation starts turning later to instability. Such behavior was observed with the inclined arrangement as well as with previous horizontal arrangements [3, 4]. Also in the case of the inclined arrangement, the role of the ‘triple points’ (i.e. the points where air, polymeric surface and droplet meet each other) is vital. The forces exercised on the droplets, because of the applied electric field, are quite strong, and therefore, the ‘triple points’ move towards the electrodes. Experimental data

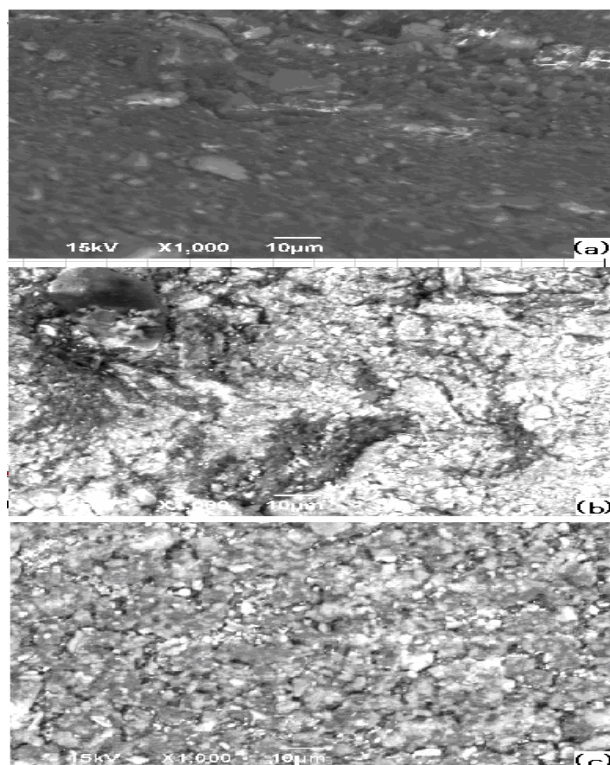

Fig. 9 SEM micrographs of the Silicone Rubber insulation surface (a)Virgin (b) Partially damaged (c) Fully damaged by arc.

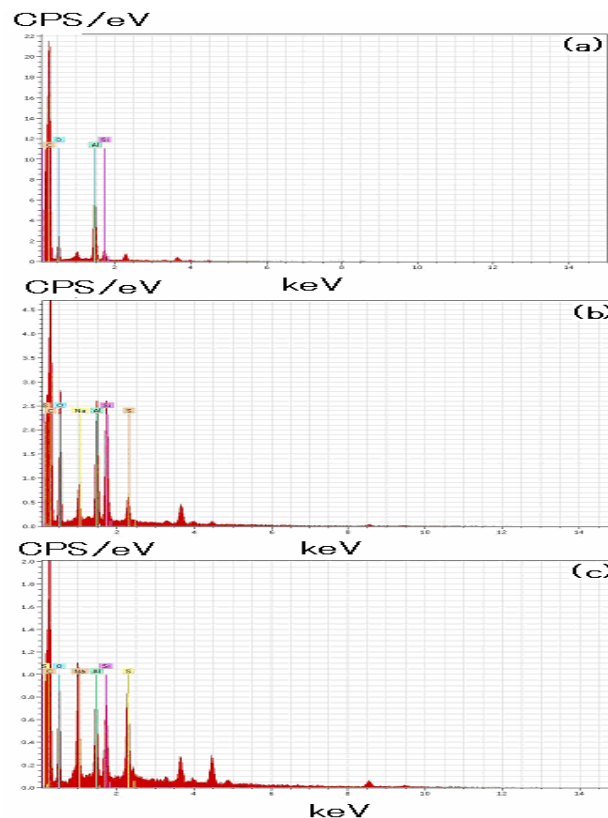

Fig. 10 EDAX Analysis of the Silicone Rubber insulation surface (a)Virgin (b) Partially damaged (c) Fully damaged by arc.

Open Science Index, Materials and Metallurgical Engineering Vol:3, No:2, 2009 publications.waset.org/10710.pdf

published recently, validate what is reported here [13]. Such movement of ‘triple points’ causes the spread of the droplets. The spread of droplets is perhaps the most characteristic phenomenon observed with the inclined electrode arrangement. It is not, however, the only one observed. Droplet oscillation, formation of water paths, collapsing of two droplets into a larger one, ejection of small charged droplets from a larger one, were also observed. In this respect, the present work offers similar conclusions with those in [3, 4, 13, 14].

Fig. 9 a-c show SEM photographs of the virgin material and the various stages of surface damage that occurred due to discharges with the silicone rubber insulation. Fig. 10a-c shows the EDAX analysis of the silicone rubber insulation with different level of damage. In the case of the partially damaged surfaces, a change of the molecular composition of the surface was observed. This is partially due to the high temperatures developed during the flashover. In the partially damaged surface, large quantities of C and O, Al and Si were also observed. Also Na and S were also detected. The element Na obviously resulted from dissociation of NaCl solution forming precipitation which was observed in EDAX analysis. The same chemical elements were observed in the case of the totally damaged surface, although the quantities were somehow different. In general it could be ascertained based on the present study that decomposition variation occurs at the surface of the material depending on the magnitude of discharges.

## VI. CONCLUSION

Water droplet conductivity, polymer surface roughness, droplet volume and the positioning of droplets with respect to the electrodes constitute important parameters affecting the behaviour of droplets under the influence of an electric field with an inclined plane electrode arrangement. Increased conductivity, smoother polymer surfaces and increased droplet volume cause a reduction of the flashover voltage. The droplet positioning with respect to the electrodes plays a vital role in reducing the flashover voltage and, on occasions, is more important than the droplet volume. The SEM and EDAX results confirm that surface composition variation is directly related to magnitude of discharges.

## REFERENCES

- [1] Kind, D. – Kaerner, H.: High Voltage Insulation Technology, Braunschweig: Eds. Vieweg, 1985.
- [2] Danikas, M. G.: Surface Phenomena on Resin-Type Insulators under Different Electrical and Non-electrical Stresses in the Early Stage of Ageing”, *Facta Universitatis* 13 (2000), 335-352.
- [3] Karakoulidis, K. – Danikas, M. G. – Rakitzis, P.: Deterioration Phenomena on Insulating Surfaces due to Water Droplets”, *Journal of Electrical Engineering* 56 (2005), 169-175.
- [4] Danikas, M. G. – Rakitzis, P. – Karakoulidis, K.: Study of Parameters Related to Deterioration Phenomena due to Water Droplets on Polymeric Surfaces”, *Journal of Electrical Engineering* 57 (2006), 130-137.
- [5] Danikas, M. G.: Ageing Properties of Silicone Rubber Materials Used in High Voltage Composite Insulators, *Journal of Electrical and Electronics Engineering (Australia)*, 15 (1995), 193-202.

- [6] Kloes, H.-J. – Koenig, D. – Danikas, M. G.: Electrical Surface Discharges on Wet Polymer Surfaces, Proceedings of the 8th International Symposium of Gaseous Dielectrics, Virginia beach, Virginia, USA, pp. 489-495, June 1998.
- [7] Koenig, D.: Surface and Aging Phenomena on Organic Insulation under the Condition of Light Contamination and High Electric Stress, Proc. of the Nordic Insulation Symposium, Vaasa, Finland, pp. 17-35, June 1994.
- [8] Hartings, R.: The AC-Behavior of a Hydrophilic and Hydrophobic Post Insulator during Rain, IEEE Winter Power Meeting, New York, USA, 1994.
- [9] Dan Windmar: Water Droplet Initiated Discharges in Air, Ph. D. Thesis, Uppsala University, Uppsala, Sweden, 1994.
- [10] Schutte, T.: Water Drop Dynamics and Flashover Mechanisms on Hydrophobic Surfaces, Proc. of the Nordic Insulation Symposium, Vasteras, Sweden, paper 8.1, June 1992.
- [11] Mason, J. H.: Discharges, IEEE Transactions on Electrical Insulation, 13 (1978), 211-238.
- [12] Vlastos, A. - Gubanski, S.: Surface Structural Changes of Naturally Aged Silicone Rubber and EPDM Composite Insulators, IEEE Transactions on Power Delivery, 6 (1991), 888-900.
- [13] Keim, S. - Koenig, D. - Hinrichsen, V.: Experimental Investigations on Electro-hydrodynamic Phenomena at Single Droplets on Insulating Surfaces, Annual Report of the Conference on Electrical Insulation and Dielectric Phenomena, Albuquerque, New Mexico, USA, pp. 133-136, October 2003.
- [14] Keim, S.: Optical Diagnostic of Single Droplets on Polymeric Insulating Surfaces in an Electric Field to Describe the Phenomena of the Beginning of Aging Mechanisms, Ph. D. Thesis, Darmstadt University of Technology, Darmstadt, Germany, 2003 (in German).