

Assembly Process Algorithms of Flexible Cell

M. Kusá, M. Matúšová, A. Javorová and K. Velíšek

Abstract—This paper deals about four items assembly process of linear drive. This assembly will be realized in flexible assembly cell on Institute of Manufacturing Systems and Applied Mechanics. There is defined manufacturing cell, individual actuators created our flexible cell. Next chapter is about control type, detailed describe a sequence control type, which will be used in mentioned flexible assembly cell. All cell control is divided in individual steps instructions. There instructions illustrate table number III.

Keywords—assembly, flexible cell, sequence control

I. INTRODUCTION

THE role of the production system is rationalizing the performance of specified technological process so that half product is transformed into final product with geometry defined by technical drawing and fulfilling qualitative requirements imposed by technical conditions:

A. According to production type:

- phase production (small-scale production) – production process is organized according to technological similarity of production machines, material flow is in batches, general purpose accessory of a work-place, production times are long and assortment is changeable
- group production (small and medium scale production) – regularly repeating production, irregularly repeating production
- flowing production – 1 or more products, layout of workshops corresponds with sequence of technological operations, products having reserved workshops, time between workshops is minimized.

B. According to utilized automation:

Inflexible building such production system does not take into account frequent change of production program over an entire lifetime. Field of application is mainly for mass production. Machines, transportation and manipulation devices have special purpose design

Flexible building of such systems takes into account with frequent or repeating change of production program over a period of production system life-time. This is typical predominately for field of single and small scale production. Machines, transfer and manipulation devices have multipurpose design [2].

M. Kusá, M. Matúšová, A. Javorová and K. Velíšek are with the Slovak University of technology in Bratislava, Faculty of Material Sciences and Technology in Trnava, Institute of Production systems and Applied Mechanics Razušova 2, 917 00 Trnava, Slovakia (phone: 00421906068612; e-mail: martina.kusa@stuba.sk, miriam.matusova@stuba.sk, angela.javorova@stuba.sk, karol.velisek@stuba.sk).

C. According to type of products:

- Single object
- Multiobject

D. According to time bonding:

- Synchronized – operation times are same
- Nonsynchronized – operation times are different

Production systems consist of five elements. There are:

- Subsystem of manufacturing and assembly
- Subsystem of material flow
- Subsystem of information flow
- Service and maintenance
- Personnel

TABLE I
 ELEMENTS OF MANUFACTURING SYSTEMS

Subsystem	Function	Objects	Main components
Manufacturing and assembly	Material working, assembly of components of the final product and gradual increase of its value	Products	Manufacturing facilities -machines -tools -allowance -measuring gauges -cutting fluids
Material flow	Transfer, manipulation and product storage	Products, tools, measuring and control devices, secondary facilities	Transferring devices -carts -cranes -manipulators Secondary facilities -palette -storages -jaws
Information flow	Storage, sorting, transfer and processing of information	Specification and information	Hardware -computers -terminals Software -operation systems -application -computer programs

II. ARRANGEMENT OF WORKSTATIONS/MACHINES IN THE PRODUCTION PROCESS

A. Random arrangement

This is a random arrangement of workstations / machines. Random arrangement is suitable for the workplaces where it is not possible to determine the plant situated material flow, the continuity of operations, or organizational and management relations.

In particular it means the prototypes and maintenance workstations that are characterized by individual production.

B. Technological arrangement

Technology organization brings a similar arrangement of workstations / machines together. That is creating a group of technology-related machines. It is used in single and small batch production, where the diversity of produced parts impossible to unite the direction of material flows.

C. Objective arrangement

The characteristic feature of the objective arrangement is the sort of workplaces / machines according to the operations of the technological process produced components or groups of shapes and technologically similar parts. Material flow of the product has the same direction. This creates a manufacturing flow - line. The arrangement is used in the scale and mass production.

D. Modular arrangement

Modular arrangement is characterized by the group of same technological units, each of which perform more technological features. The workplace consists of the same or similar groups of workstations - modules. It is characterized primarily in single and small batch production.

E. Cellular and "nest" arrangement

Cellular and "nest" arrangement, as the basis for division, consists of highly productive machines with mechanized or automated environment (robots, tanks etc.). It is used in facilities with a large production program to ensure full and continuous use of a cell. Alternatively, there is "nest" arrangement. It is proposed primarily for stationary installation which is not related time to time.

F. Combined arrangement

Design of large-scale production units requires combining two or more of the above-mentioned arrangement. The most common combination used in a practice is the merger of technology and objective arrangement. The aim is to benefit of both arrangements and to eliminate their weaknesses.

III. ASSEMBLY SYSTEM

Assembly systems generally consist of a large set of modular elements, units and subsystems, which are linked by a complex set of functional relationships and properties. Application of systemic approaches in designing assembly systems leads to their partial decomposition of subsystems, units and elements that can analyze in terms of their properties, relations and functional behavior of the assembly process. Elements are the smallest building units, which are specialized in assembly department. Assembly work is ensuring a coherent and closed sub-assembly process. The methodology for design of assembly systems is based on the basic model assembly, which consists of three basic elements:

- assembly product,
- assembly process,
- assembly system.

Assembly product:

- The structure of the product - a product decomposition to assembly parts, sub-components and identifying relationships between them.
- The evaluation of product - in terms of its assembly capacity.
- Product Components - parts and subassembly class of the product, the lowest level, identifying characteristics, classification [1].

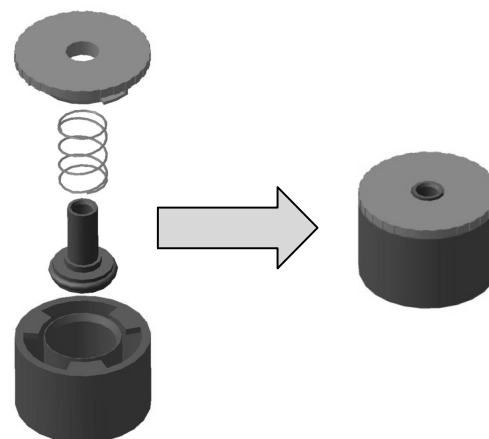

Fig. 1 The structure of the assembly product

Assembly process:

- Assembly task - the highest level which is set up according to the degree of operations concentration on the subassembly and method of their integration into final assembly and so on.
- Technological process - technological process of assembly and its possible variants, assembly operations, identification of parameters.
- Evaluation assembly process.

Assembly system:

- System characteristics - determine the essential characteristics, such as flexibility, automation, etc., the transport strategy.
- Components of assembly system - assembly system elements (technical equipment, robots, transportation systems, etc.), which implement the functions of their choice or design principles.
- Structure assembly system - global position assembly system components and their relationships, analysis of the functioning and others.

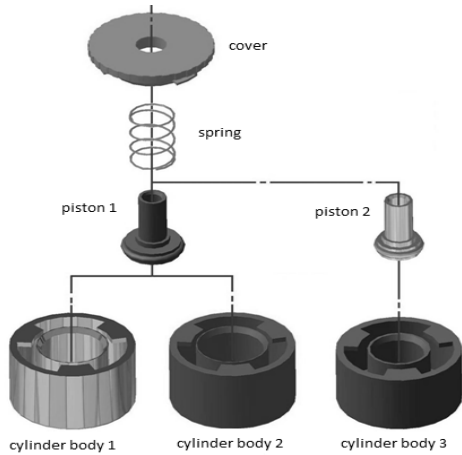

Fig. 2 Assembly variability in the graph

IV. ANALYSIS OF FLEXIBLE ASSEMBLY CELL

Model of flexible manufacturing cell on Institute of Manufacturing Systems and Applied Mechanics shows multi-handling assembly facility that has integrated into five production stages through which every product must pass during its production. They are:

- storage of semiproduct and its transport to the manufacturing equipment,
- semiproduct machining to final product,
- manipulation of individual parts,
- the assembly of individual components into a finished products,
- final product manipulation and its storage before expedition.

The device consists of a whole shelf storage system, which will serve the storage of intermediate products, individual components and the finished product. Shelf storage system will take a variety of pallets with different work pieces or parts from store shelves and put them to rotary feed device which is used for administration of pallets into and out of the workspace from the workspace multifunctional industrial robot, with which they will perform manufacturing and assembly operations. The workspace of an industrial robot is placed the rotary clamping device that can perform continuous rotational movement of the chosen direction and speed, such as a lathe chuck and allow accurate positioning of the workpiece by rotating around its vertical axis. The whole device is controlled via an industrial PC. How energy medium throughout the facility will be used electricity and compressed air (pneumatics, electro-pneumatics [3].

Five working phases are integrated in the flexible assembly cell:

- storage (storage of semi products, final products before its expedition)
- transport and manipulation (transport and manipulation with half products and final products)
- manufacture (manufacturing of single half products to the final product)
- assembly (assembly of single parts in to the one final product)
- expedition

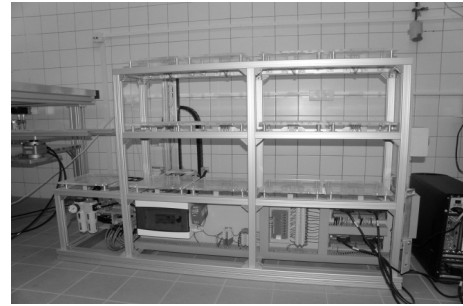
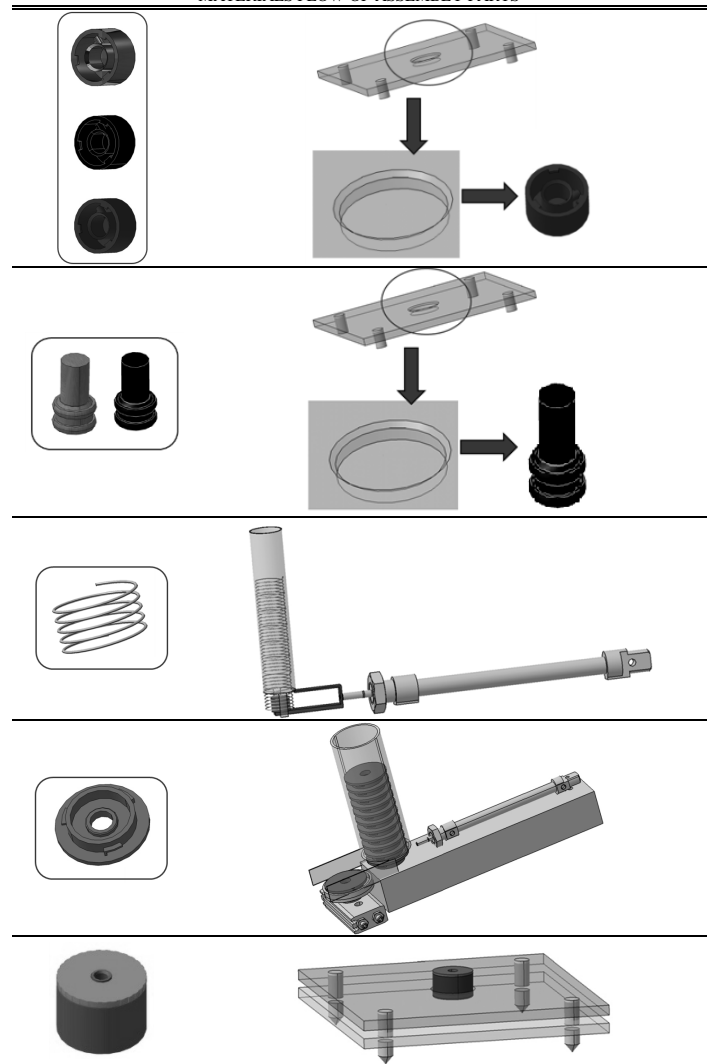

Fig. 3 Shelf storage system

TABLE II
 MATERIALS FLOW OF ASSEMBLY PARTS



Individual assembly parts are located in magazines (Table II.) Pallets are made for cylinder bodies and pistons. There are made from acrylic glass with milled blind hole for parts alignment. Pallets movement is providing by shelf storage system. Individual parts choose are realized according to program requirements. Springs and covers are placed in assembly cell workspace. There are in magazine with selector by double acting cylinder.

TABLE III
STEPS INSTRUCTIONS OF SEQUENCE CONTROL OF ASSEMBLY CELL

Step	Shelf storage system	Rotating unit	Cartesian robot	Clamping fixture	Spring magazine	Cover magazine
1	Takes a pallet with cylinder body and places it on the rotary unit.					
2		Check the type of cylinder body - sensors on the console				
		Rotation by 180 degrees into the workspace				
3	Goes for pallet with piston and loads it on the rotary unit.		Takes the component from the rotating unit to orientation unit			
		Rotation by 180 degrees				
			Takes the cylinder body from orientation unit and inserts it to the fixture			
4	May supplement stack with new pallets		Change of the gripping head	Clamps component		
5	May supplement stack with new pallets		Takes the piston and inserts it into the cylinder body			
6	May supplement stack with new pallets		Change of the gripping head		Slide the spring	
7			Takes the spring and pushes it onto the piston			
8			Change of the gripping head			Slide the cover
			Takes the cover to orientation unit			
9			Takes the cover assembles it			
				Clamp release product		
			Takes the product and places in to the unit functionality control			
10		Rotation by 180 degrees				
			The finished product is stored in a variety of			
11	Takes the pallet of the cylindrical body and places on the rotation unit					
12		Rotation by 180 degrees				
	Pallet with the assembled product places on the input/output					

V. CONTROL METHODS OF PRODUCTION SYSTEM

Automatic control can be classified according to

A. Control signal type generated by the control system

- analog control
- binary control
- digital control

B. Method of processing the control signal

- combinational control
- sequence control

C. Way the save program in automated equipment

- Memory control system
- Control system programmed interconnection

When selecting a suitable control method should consider the following:

- labor requirements and costs,
- preferred control method ,
- technical and operational resources that are available to project support
- existing system environment, which will be integrated into the new project.

Control classification by processing control signal has more theoretical nature. This classification is not indicative of what the control method is required. Suitable control type we can choose by type of input and output signals.

Many control applications do not involve analog process variables, that is, the ones which can assume a continuous range of values, but instead variables that are set valued, that is they only assume values belonging to a finite set. The simplest examples of such variables are binary variables that can have either of two possible values, (such as 1 or 0, on or off, open or closed etc.). These control systems operate by turning on and off switches, motors, valves, and other devices in response to operating conditions and as a function of time. Such systems are referred to as sequence/logic control systems. For example, in the operation of transfer lines and automated assembly machines, sequence control is used to coordinate the various actions of the production system. This control type consists of steps with defined sequence. A steps sequence is depends on defined conditions [4].

Detailed analysis of all the actuators are necessary to preparing control algorithm. Flexible assembly cell consist of six actuators. There are:

Shelf storage system - 3-axis manipulator which provide material flow 2 assembly components – cylinder body and piston. This actuator tasks are:

- pallet with parts insert to storage system
- pallet with required part takes from storage systems and insert to rotary unit
- pallet with assembled products takes from rotary unit and insert to unloading area
- empty pallets takes from z rotary unit and stores the unloading area

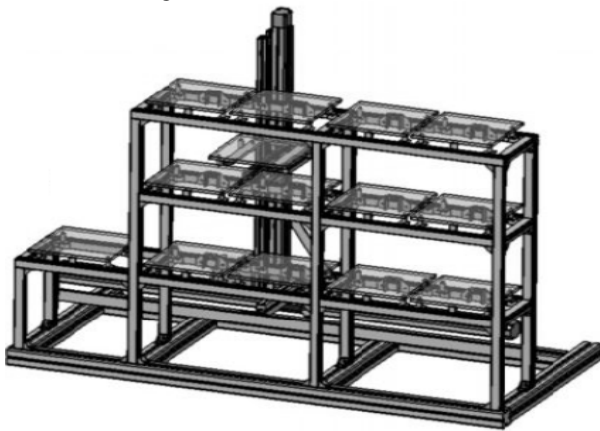

Fig. 4 Shelf storage system

Rotating unit – interface between the assembly cell and shelf storage. Its tasks are:

- ensure inputs 2 components in assembly process,
- ensure the final products output from assembly cell area [5], [6].

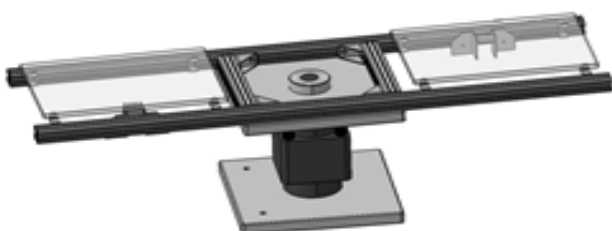

Fig. 5 Rotating unit

Cartesian robot – 3 axis robot kinematic structure TTT. The kinematic chain consist of translational kinematics pairs in three axes x, z, and z. The workspace of this robot is rectangular with dimensions 1000x1000x350mm. Its tasks are:

- ensure assembly parts removal and insertion from rotating unit to clamping fixture
- perform assembly process by two gripping head
- ensure finished product to rotary unit.

Clamping fixture- self centering prism clamp fixture with parallel jaw movement. Its task is:

- ensure clamping cylinder body during the assembly process

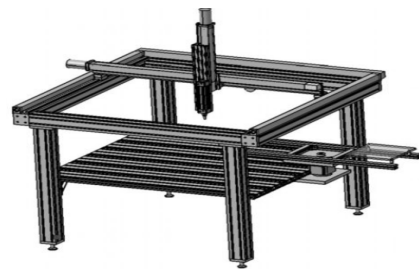

Fig. 6 Cartesian robot

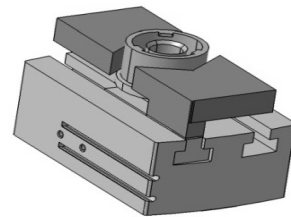

Fig. 7 Clamping fixture

Springs magazine – magazine with linear cylinder.

- Push the part from the magazine.

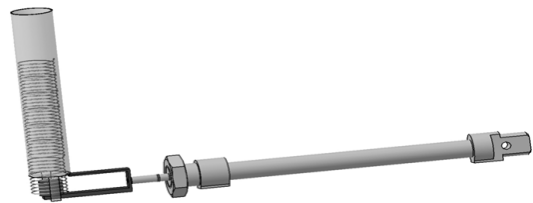

Fig. 8 Springs magazine

Cover magazine – magazine with linear cylinder

- Push the part from the magazine.

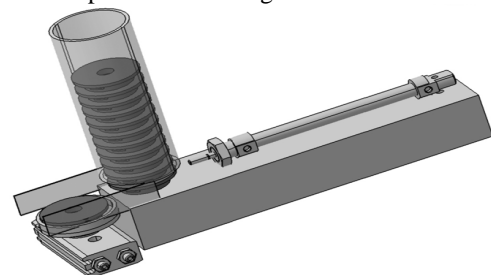

Fig. 9 Covers magazine

VI. CONCLUSION

Modern manufacturing is currently located in production areas and production areas require the integration of different types of engineering and manufacturing operations. Therefore production philosophy allowing the integration of control, organizational, monitoring and other innovative type of activities into one unit is needed. Due to the relatively high variability of real production technologies, dominant technologies, production volumes, production flows, production use funds and many others, further consideration and analysis of the problem are focused on area of modern automated, especially robotized production.

Cell production in recent years becomes one of the most important studies of production arrangement. These studies include several methods based on finding a relationship between relational components - cell, which has guaranteed the production of various components with a small number of pieces in the batch. Cellular structures achieve a consistency between machines, saving time and space. Machine process is synchronized, material flow is fast (move parts from machine to machine is in a short distance).

ACKNOWLEDGMENT

This paper was created with support of the national project VEGA 1/0206/09 Intelligent assembly cell.

REFERENCES

- [1] J. Oravcová, P. Košťál and E. Riečičiarová "Active parts of clamping devices," In: Annals of The Faculty of Engineering Hunedoara. - ISSN 1584-2665. - Tom VIII, Fas. 1 (2010), pp. 235-236.
- [2] M. Charbulová, A. Mudriková, and N. Danišová, "Fixture devices for production systems." AMO Journal, ISSN 1313-8987, Iss. 4, Vol. 1, 2010, pp. 21-24. In: AMO Conference. - ISSN 1313-4264. - 10. International conference, 27 - 29 June 2010 AMO 10, 27 June - 01 July 2010 CEEPUS (2010), pp. 1-6.
- [3] N. Danišová, "Intelligence in roboted assembly." In: RaDMI 2007 : Proceedings on CD-ROM of 7th International Conference "Research and Development in Mechanical Industry - RaDMI 2007", Belgrade/Serbia/, 16-20 September 2007. - Trstenik : High Technical Mechanical School of Trstenik, 2007. - ISBN 86-83803-22-4. pp.569-574.
- [4] S.L. Maskara: Communication Networks and Switching, Web Course, IIT Kharagpur, India, <http://nptel.iitm.ac.in/courses.php?disciplineId=117>.
- [5] N. Danišová, and J. Majerík, "Jaw types design at the intelligent manufacturing-assembly cell. In: Annals of Faculty of Engineering Hunedoara - Journal of Engineering. - ISSN 1584-2673. - Tom IX, Fasc. 3 (2011), pp. 279-281.
- [6] N. Danišová: and J. Majerík, "Sensoric system for identification of jaws in the jaw buffer and intelligent fixture." In: Annals of Faculty of Engineering Hunedoara - Journal of Engineering. - ISSN 1584-2673. - Tom IX, Fasc. 3 (2011), s. 441-442.