

Intelligent Home: SMS Based Home Security System with Immediate Feedback

Sheikh I. Azid, and Bibhya Sharma

Abstract—A low cost Short Message System (SMS) based Home security system equipped with motion, smoke, temperature, humidity and light sensors has been studied and tested. The sensors are controlled by a microprocessor PIC 18F4520 through the SMS having password protection code for the secure operation. The user is able to switch light and the appliances and get instant feedback. Also in cases of emergencies such as fire or robbery the system will send alert message to occupant and relevant civil authorities. The operation of the home security has been tested on Vodafone- Fiji network and Digicel Fiji Network for emergency and feedback responses for 25 samples. The experiment showed that it takes about 8-10s for the security system to respond in case of emergency. It takes about 18-22s for the occupant to switch and monitor lights and appliances and then get feedback depending upon the network traffic.

Keywords—Smart Home, SMS, Sensors, Microprocessor.

I. INTRODUCTION

SMART Home' referred to as 'Intelligent Home' or 'Automated Home', indicates the automation of daily tasks with electrical devices used in homes. This could be the control of lights or more complex chores such as remote viewing of the house interiors for surveillance purposes. The emerging concept of smart homes offers a comfortable, convenient, and safe environment for occupants. Wireless technologies had some amazing achievements in automating homes via Bluetooth, ZigBee, and Wi-Fi but had a limited connectivity range [1-4]. The use of internet is also being probed to develop automated home technologies [5]. Mobile phones have become one of the most common communication devices amongst the people all over the world. SMS became popular as it provides cheap, convenient and faster method of communication. Unlike the Internet, SMS is safe from network security threats and can be operational from anywhere in the world where there is a mobile network. The advantage of SMS over ZigBee, Bluetooth and Wi-Fi is that it is communication range from anywhere in the world where is mobile network.

The penetration of internet connection for home automation is the new dimension as technologies continues to grow [5]. Global System for Mobile Communication (GSM) module was then introduced for home automation [6]. The GSM module system is battery powered which made home

automation system safer from internet hacks. Home automation has also further advanced in successfully merging communication technologies GSM module, internet, and speech recognition system [5]. The wireless automation reduces the cost of the system unit as well as it is much easier to install. The GSM module has advanced to automobiles. It is interfaced with the car ignition system where the owner carries the mobile phone rather than to carry around the key [7]. Recent advances in the automation showed that the billing system for electricity, gas or water uses GSM module based SMS metering service rather than assigning person to visit each house and read the meter readings manually in cases of South Pacific [8]. However, the GSM module has some drawbacks as it cannot behave like what the actual mobile does. GSM module users have to remove the SIM card for recharge top-up. There is more exposure in using the GSM network if only the mobile is interfaced rather than GSM module.

In this paper we present SMS based Smart Home with feedback response. This system interfaces the mobile phone with embedded microprocessor PIC18F4520 and sensors which is based in the intelligent home. The user can use SMS for monitoring and controlling lights, home appliances and security sensors and get feedback on the same mobile phone about the status of different appliances. The entire system is password protected which can only be changed by the user. The system is generic as it can work with any mobile network. The system designed has two way switching properties which means that the home 240V AC or 110VAC electrical appliances, lights, appliances and sensors can be switched on and off by mobile phone and also by the manual switches.

II. CONTROL, ARCHITECTURE AND MANAGEMENT OF THE SYSTEM

The overall architecture design and networking of the home system is shown in Fig. 1. The system first it checks the battery charge level of the mobile phone every cycle of the coding, that is, about 15 seconds and automatically turns on the battery charger if battery level is below 30%. It then reads the message received by the mobile phone interfaced with the microprocessor. The microprocessor then stores the phone number from which the message is received for feedback purpose. If the message indicates low credit, it sends callback message to user indicating that credit is low (Callback message is free for Vodafone Fiji Network). The system then looks for

Sheikh I Azid is with Faculty of Science Technology and Environment, The University of the South Pacific, Laucala Campus, Fiji (phone: +679 3232859; fax: +679 3231416; e-mail: azid_s@usp.ac.fj).

Bibhya Sharma is with Faculty of Science Technology and Environment, The University of the South Pacific, Laucala Campus, Fiji (phone: +679 3232069; fax: +679 3231416; e-mail: azid_s@usp.ac.fj).

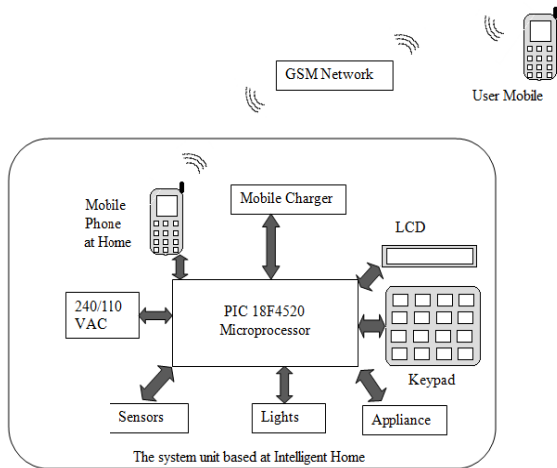

Fig. 1 Architecture of Intelligent Home system

password in the message if password is wrong it replies to origin SMS indicating "incorrect password". If password matches then it searches for command to be executed in the message, does the required task and then writes the feedback in form of message to reply to the sender. The user can activate any appliances, lights or sensors to check their status in the house via SMS using any mobile phone and from anywhere where there is mobile network. If the SMS sent to home does not contain the password the home will reply to the same number indicating "PASSWORD INCORRECT". This password can be only changed by the user from home. Once the SMS is received, the microprocessor (PIC 18F4520) reads it and performs the task directed by the user and informs the status of light and other sensors in the home. When an event occurs which demands the microcontroller's attention, an interrupt is generated, which instructs the microcontroller to stop what it is doing and take care of the higher priority task. In case of an interrupt the microprocessor checks the emergency mobile number saved by the user in the home. Then the microprocessor writes the emergency message and sends it to user or relevant civil authorities. The message to be sent is a stored message stating type of emergency and the location of the intelligent home. For example "Smoke Detected at 117 Laucala Bay Rd, Suva" After sending the message the microprocessor will jump back to the function it was doing before interrupt.

The sensors are calibrated and programmed to read physical status of the intelligent home and give feedback. The smoke detector is always active in the Intelligent Home and is connected to the Interrupt PIN, whereas the motion detector has to be turned on/off by the user. The motion detector is turned on/off by either SMS or manual switch located inside the home.

The system uses the Light Dependent Resistor (LDR) which detects the status of the light and gives an analog output. Corresponding to the status of the lights the analog to digital conversion of the LDR output is done by the PIC 18F4520 microcontroller programming. The AT commands are used to communicate with the mobile phone. AT is the abbreviation of

"Attention". The interfacing between the mobile phone and the microprocessor is such that it can communicate with any mobile phone which can be connected serially to modems. The system based at home is generic, thus any mobile phone which supports AT command will work with the microprocessor provided they are interfaced serially. In addition, it is not necessary that the user number be emergency number. The user can easily change the emergency number on the unit at home. The C language program controlling the microprocessor uses 706.5 KB of RAM and 16711.68 KB ROM.

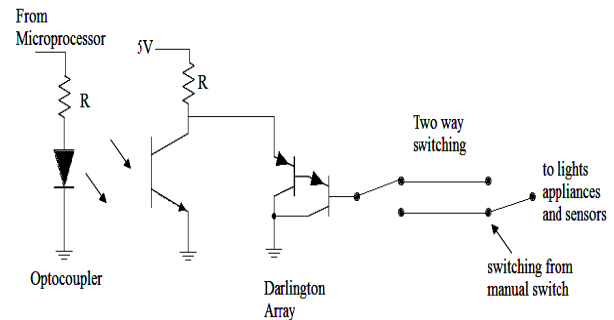

Fig. 3 Switching from low voltage to high voltage

The lights and other appliances controlled in the Intelligent home have two-way switching system. One of the sides of the switching is manual and the other side is controlled by the microprocessor. Single Pole Double Throw (SPDT) relay is used to fulfill the two way switching from the microprocessor side. For the two way switching system, the light and appliances can be turned on or off from any side of the switch as shown in Fig. 3.

The current from the microprocessor is not enough to switch on the relays. Darlington array is used to boost the current supply to the relays as shown in Fig. 3. Each channel for is rated at 500 mA and can withstand peak currents of 600 mA. Suppression diodes are included for inductive load driving and the inputs are pinned opposite to the outputs to simplify the board layout.

The microcontroller output is 5V which drives the relays to control the 240V AC. When the relay switches, the counter electromotive force is generated that can freeze the microcontroller. An Opto-coupler is used to solve the counter electromotive force problem by creating a wireless zone between the transmitter and the receiver sides in the Opto-coupler. Infrared transmitter and receiver have been used to design the Opto-coupler.

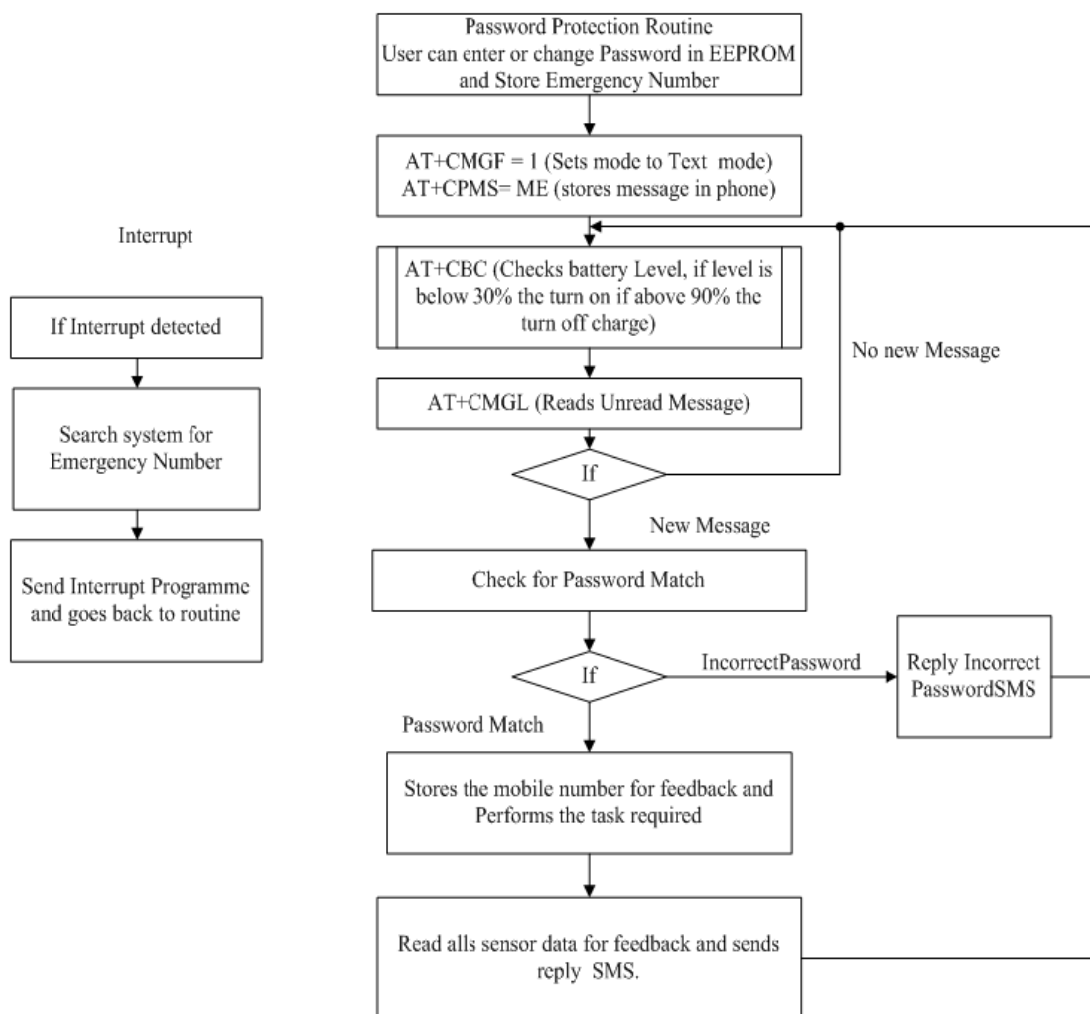

Fig. 2 Programming Flowchart of the System

III. EXPERIMENTATION ON THE NETWORK

An experiment was design to obtain the time taken for Intelligent home to perform task given by the SMS and send feedback. In Fiji Islands there are two mobile networks. These are Vodafone Fiji network and Digicel Fiji network. The mobile phone based at the home mobile uses Vodafone Fiji network, as this network provides the “callback” and “Insufficient credit” features which are useful for the intelligent home design, which is not available for Digicel Network currently in Fiji.

First a set of 25 SMS were sent from the user using Vodafone Fiji Network and Digicel Fiji Network to activate and deactivate the lights, switches and sensors at home. Fig. 3 shows that it takes an average of 20.16s for the user to send the message to the smart home to respond to the message sent by the user and for the mobile phone based in the home to give feedback to the user between Vodafone Fiji to Vodafone Fiji network. Moreover, it takes an average of 20.56s for the same

task using Digicel Fiji to Vodafone Fiji network. Hence SMS within the same network works faster.

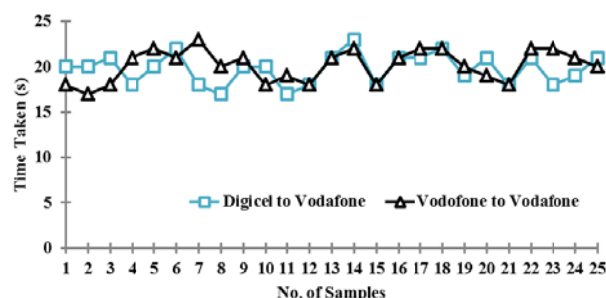

Fig. 4 The Time taken by samples between Vodafone Fiji to Vodafone Fiji Network and Digicel Fiji to Vodafone Fiji Network

Another experiment was designed to get the time taken of 25 samples for the home to send an emergency SMS to the user and appropriate civil authority. Emergency situation in the design includes smoke detected at home and movement

outside home without the permission of the occupant. Fig. 4 illustrates that the user as well as the appropriate civil authorities will get an emergency SMS within Vodafone Fiji to Vodafone Fiji network in an average time of 9.16s and 9.36s between Digicel to Vodafone network.

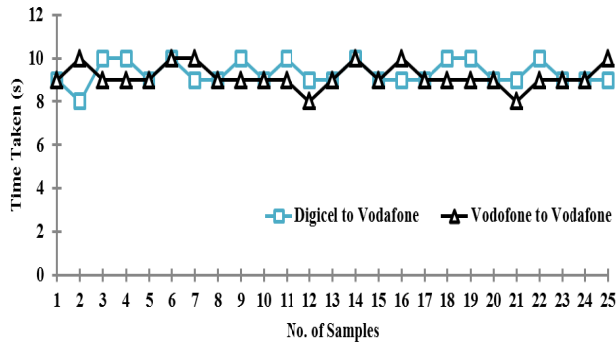

Fig. 5 The Time taken by samples between Vodafone Fiji to Vodafone Fiji Network and Digicel Fiji to Vodafone Fiji Network for emergency SMS

IV. CONCLUSION

A cost effective and SMS operated home security system has been designed and tested with the mobile network. The performances of commercially available sensors were first studied for their feasibility before installation in the intelligent home. The AT commands have been used that provide a flexible way to control and explore the services of the mobile. The communication with the home is solely through SMS which has been tested with mobile networks and is expected to work on any mobile network. The SMS should contain password anywhere in the message for the home to respond. In case of no password or incorrect password it will reply incorrect password message. In case of emergency the system will send an emergency SMS to the user and relevant civil authority in an average of 9.16s. This is one of the most effective and intelligent design to have at home for security and safety purposes. Moreover the same design can be used in business and other important places.

ACKNOWLEDGMENT

Authors would like to thank The University of the South Pacific, Faculty of Science Technology and Environment for financial support in carrying out this work (Grant No. 6C161).

REFERENCES

[1] Balasubramanian, K., Cellatoglu, A. (2009) "Analysis of Remote Control Techniques Employed in Home Automation and Security Systems", *IEEE Transactions on Consumer Electronics*, 55 (3), 1681-1687.

[2] Tajika, Y., Saito, T., Termoto, K., Oosaka, N., Isshiki, M. (2003) "Networked Home appliance system using Bluetooth technology integrating appliance control/monitoring with internet service", *IEEE Trans. Consumer Electron.* 49 (4), 1043-1048.

[3] Gill, K., Yang, S.H., Yao, F., Lu, X. (2009) "A Zigbee Based Home Automation system", *IEEE Transactions on Consumer Electronics*, 55 (2).

[4] Jin, M.H., Fu, C.J., Yu, C.H., Lai, H.R., Whei, M. (2008) "IBM3 Zigbee Positioning Method for Smart Home Applications", *International Journal of Smart Home*, 2(2).

[5] Yuksekkaya, B., Kayalar, A.A., Tonsun, M.B., Ozean, M.K., Alkar, A.Z. (2006) "A GSM, Internet and Speech Controlled Wireless Interactive Home Automation System", *IEEE Transactions on Consumer Electronics*, 52(3).

[6] Zhao, Y., Ye, Z. (2008) "A Low Cost GSM/GPRS Based Wireless Home Security System", *IEEE Trans. Consumer Electronics*, 54(2), 567-572.

[7] Karim, J., Amat, W.M.A.B.W., Razak, A.H.A. (2009) "Car Ignition System via Mobile Phone", *International Conference on Future Computer and Communication*.

[8] Ur-Rahman, M.W., Ahmed, M.T., Khan, T.H., Kabir, S.M.L. (2009) Design of an Intelligent SMS based Remote Metering System, *IEEE Conference Information and Automation*, 22-24 (2009).

[9] Azid, I.S., Kumar, S. (2011) "Analysis and Performance of a low cost SMS based Home security system", *International Journal of Smart Home*, 5(3) 15-24

[10] Azid, I.S., Kumar, S. (2011) "Monitoring and Operation of Intelligent Home System Using Password Protected SMS Service", *Journal of Intelligence Systems*.

Sheikh Izzal Azid received his MSc in the area of ICT (Communication, Networking and Security) in 2010 and BE-Tech in Electrical and Electronics Engineering from the University of the South Pacific. Currently he is Assistant Lecturer in School of Engineering and Physics at the Faculty of Science Technology and Environment. His research interests include mobile and wireless communication, embedded microprocessor applications, intelligent system, robotics, automation, mobile networks and security.

Bibhya N. Sharma received his PhD in applied mathematics from The University of the South Pacific, Fiji, in 2009. He is currently a senior lecturer in Mathematics in the Faculty of Science, Technology and Environment, University of the South Pacific. He is also the Associate Dean of Learning and Teaching in the Science Faculty. His main fields of interest are dynamics of nonlinear systems, robotics, biologically inspired systems and activities, artificial neural networks and mathematics education, especially in the areas of e-learning and m-learning using the new technological tools.