

A Novel Fuzzy Logic Based Controller to Adjust the Brightness of the Television Screen with Respect to Surrounding Light

A. V. Sai Balasubramanian, N. Ravi Shankar, S. Subbaraman, and R. Rengaraj

Abstract—One of the major cause of eye strain and other problems caused while watching television is the relative illumination between the screen and its surrounding. This can be overcome by adjusting the brightness of the screen with respect to the surrounding light. A controller based on fuzzy logic is proposed in this paper. The fuzzy controller takes in the intensity of light surrounding the screen and the present brightness of the screen as input. The output of the fuzzy controller is the grid voltage corresponding to the required brightness. This voltage is given to CRT and brightness is controller dynamically. For the given test system data, different de-fuzzifier methods have been implemented and the results are compared. In order to validate the effectiveness of the proposed approach, a fuzzy controller has been designed by obtaining a test data from a real time system. The simulations are performed in MATLAB and are verified with standard system data. The proposed approach can be implemented for real time applications.

Keywords—Fuzzy controller, Grid voltage.

I. INTRODUCTION

PEOPLE look into different types of display screens, either for work or entertainment. On an average a person sits in front of them for a minimum of two hours a day. The screen used in these equipments produce images and videos by providing sufficient voltage to the cathode ray tube which is of very high intensity. People surfing through the channels get affected due to the huge contrast between the outside atmospheric light and the television brightness. When the contrast difference in contrast increases additional stress is applied causing strains, headache and many visual disorders. That is why every television or a computer monitor is provided with a brightness adjustment system. This has to be optimally adjusted so that the relative illumination is less. Manual adjustment has been practiced for quite a long period, but this has not been very effective since it requires continuous adjustment of brightness depending on the intensity of the screen and outside light. These factors vary continuously with time and they also depend upon the channel provider. Automatic adjustment of contrast and brightness of

the screen suited to the external light can be done to reduce the viewers stress. So an automatic controller is proposed in this paper which controls the brightness depending upon the surrounding light. Fuzzy controller, one of the effective and intelligent options is employed in this paper to adjust the brightness in a professional manner enabling the viewer to reap the best results possible.

In [1] a fuzzy controller to control the brake rate of the automobiles has been proposed. The speed of the vehicle in which the brake is to be applied and distance of the vehicle from the point at which it has to stop are passed as input parameters to a fuzzifier. The controller compares these inputs with the rule base and gives the desired output.

In [2] a fuzzy logic based controller which dynamically adjusts the quality of the picture by adjusting the values of brightness and contrast with respect to the sensor values has been proposed.

The Literature reports in [3] propose an automatic fuzzy controller which controls the switching of headlight intensity of automobiles. In this paper, head light intensity of the approaching vehicle, the distance of the approaching vehicle and the environment in which the vehicle runs are considered as the other input parameters, the vehicles are classified on the basis of the intensity of the headlight as heavy, light, and moderate vehicle. They pass these inputs to a fuzzifier and the desired output intensity level appears in the headlight.

The Literature reports in [4] discuss a fuzzy controller which controls the headlight intensity of automobiles. The distance of the approaching vehicle from the test vehicle, the speed of the approaching vehicle, the weather condition and the road type are considered as input parameters. The fuzzifier compares this with the rule base and optimizes the headlight intensity of the automobile.

The literature reports in [7] explain briefly the origin of fuzzy logic, fuzzy sets and crisp sets, operation of fuzzy sets and fuzzy classification. Fuzzy logic provides a different method of solving problem in simpler and easier way rather than creating mathematical model.

In this paper Section 2 explains Fuzzy controller and membership functions, Section 3 explains implementation of fuzzy controller, Section gives the results and discussion and Section 5 is dedicated for references.

Authors are with Department of Electrical and Electronics Engineering, S. N. College of Engineering, India (e-mails: avsaibala@gmail.com, shankyingill@gmail.com, kumar.subba@gmail.com, rengaraj2@rediffmail.com).

II. FUZZY CONTROLLER MEMBERSHIP FUNCTION

Fuzzy controller consists of a classifier, fuzzifier, rule base, interface engine. In the fuzzy rule base, various rules are formed according to the problem's requirements. The numerical input values to the fuzzifier are converted into fuzzy values. The fuzzy values along with the rule base are fed into the inference engine which produces control values. As the control values are not in usable form, they have to be converted to numerical output values using the defuzzifier. The block diagram of the fuzzy controller used in this paper is shown in Fig. 1.

The first input parameter considered in this controller is the atmospheric light. This measures the intensity of light surrounding the screen. The atmospheric light is divided into five categories as very dark, dark, medium, bright, very bright. Very dark is total darkness, with absolutely no light source near by the viewer. The next category is dark and this is the range of intensities during early morning or late evening with no illumination source other than the sun. The medium function corresponds to late morning or early evening when the sun's power can be felt mildly. The bright function represents that hour of the day when the sun is at its peak. The very bright function corresponds to the time when the screen is surrounded by an external light source like a fluorescent tube. The membership functions used in this model are trapezoidal. The values of atmospheric light taken are measured using the photo diode BPW34. The readings are tabulated in Table I. The membership functions of first input parameter are shown in Fig. 2.

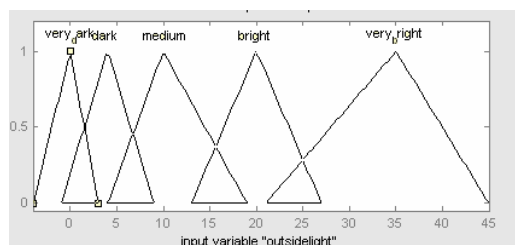

Fig. 2 Membership function of outside light

TABLE I
 OUTSIDE LIGHT INTENSITY AT DIFFERENT TIMES OF A DAY

Type	Voltage Range (mv)
Very Dark	-4 to 3
Dark	3 to 8
Medium	8 to 17
Bright	17 to 25
Very Bright	25 to 45

The second input parameter is the brightness of the screen. The grid voltages c_1 and c_2 that is applied across the cathode ray tube corresponds to the brightness and contrast respectively. The range of voltage is constant for a particular model of display screen. This voltage can be changed within this range and the brightness and contrast can be varied. This

input parameter is divided into five membership functions: very low, low, medium, high, very high. The membership functions employed here is also trapezoidal. The range of voltage of each membership function is chosen such that its brightness equivalent matches closely with the brightness of the surrounding light in any one of its range. The ranges of voltages chosen are tabulated in Table II. The membership functions of this parameter are shown in Fig. 3.

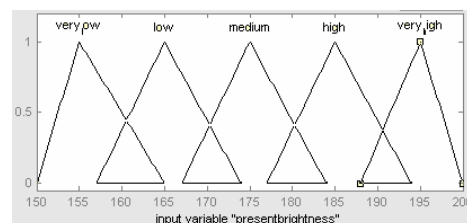

Fig. 3 Membership function of grid voltages

TABLE II
 RANGES OF GRID VOLTAGES

Type	Grid Voltage (v)
Very Low	150 – 160
Low	160 – 170
Medium	170 – 180
High	180 – 190
Very High	190 - 200

The output is also the brightness of the screen. This is same as the second input parameter. And this is shown in Fig. 4. The values of the grid voltages are given in Table II.

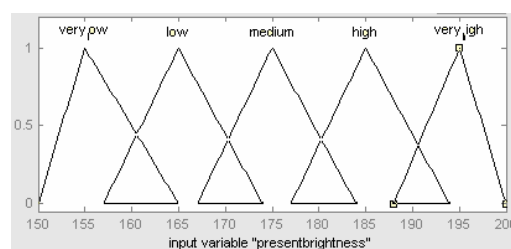

Fig. 4 Membership function of grid voltages of the output

III. IMPLEMENTATION OF FUZZY CONTROLLER

In this paper two factors have been taken into account. Atmospheric light is the first consideration. This measures the intensity of the light surrounding the screen. The brightness of the screen is the next factor that has been considered and it gives the intensity of light coming from the screen. The former is measured using a photo sensor at the top of the screen and the position of the sensor is shown in Fig. 5. The later is measured inside the screen by tapping the voltage that appears across the screen's illuminator terminals and finding the corresponding brightness. These two parameters are passed to the fuzzy controller. The fuzzifier classifies the input based on their values in one of the types. Then the

fuzzifier compares it with the rule base and the required voltage corresponding to the brightness appears at the output of the fuzzy controller. Thus the difference in illumination is continuously monitored and corrected using fuzzy logic. The defuzzification method used here is centroidal. The centroidal method defuzzifies the value. The rules are framed using all the possibilities without taking into account any don't care conditions. There are a total of $5 \times 5 = 25$ rules. The rules are given in Table III.



Fig. 5 Position of Photo Diode

IV. RESULTS AND DISCUSSIONS

In this problem the fuzzy design has a clear advantage over the conventional PID controller due to its tendency to imitate the human reasoning. There are other advantages as well. The inputs atmospheric light and the grid voltage cannot be classified completely in one particular range of the membership function. The fuzziness occurs in this case which is best resolved using fuzzy logic. The controller is tested with various defuzzification methods and Figs. 6 and 7 show the output obtained from MOM (mean of maximum method), SOM (smallest of maximum method), LOM (largest of maximum method) and Centroidal, Bisector respectively. The most suitable found out using trial and error method is centroidal and bisector. The fuzzy controller stated by mamdani suited the problem better compared to the sugano controller. This controller is more generalized method which can be extended to any television model or computer monitor with relative ease. This method is not alone restricted to CRT monitor which has grid voltage control mechanism for controlling brightness. This can be extended to LCD monitors, mobile phone screens and palmtops. Moreover this reduces the time utilized for building mathematical model. The simulations are done using MATLAB 7.0.

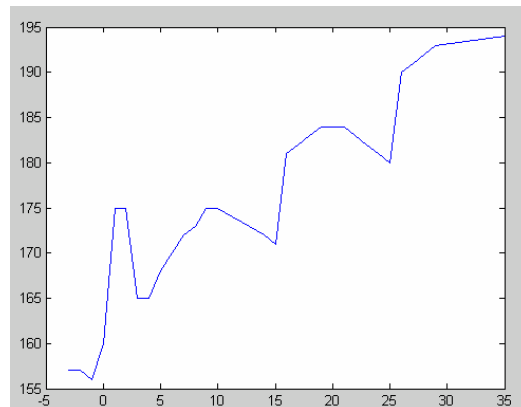

Fig. 6 Brightness of the screen Vs outside light for LOM, SOM, MOM defuzzification methods

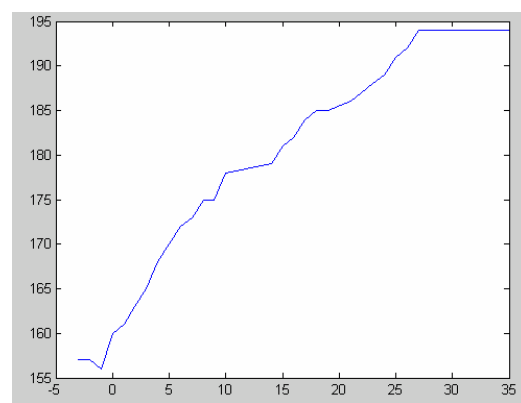

Fig. 7 Brightness of the screen Vs outside light for centroidal and bisector defuzzification methods

REFERENCES

- [1] Nikunja K. Swain, "A Survey of Application of Fuzzy Logic in Intelligent Transportation Systems (ITS) and Rural ITS"- *Southeast Con, Proceedings of IEEE, 2006, pp 85-89.*
- [2] Dalal, S.; Satyanarayana, S. "Application of fuzzy logic to picture quality improvement in televisions", *Digest of Technical Papers. ICCE, IEEE, 8-10 Jun 1993 Page(s):346 - 347.*
- [3] Kher, S., Bajaj, P., "Fuzzy control of head-light intensity of automobiles: design approach "proceedings of 37th SICE annual conference international session papers, July 1988, pp 1047-1050.
- [4] Kher, S.J.Bajaj, P.R.Sharma "A novel fuzzy control of headlight for night driving", *Intelligent vehicle symposium, proceedings of IEEE, 2000, pp-76-80.*
- [5] T.M. HusSain, T. Saadawi, S. Ahmed, "Overhead infrared sensor for monitoring vehicular traffic," *IEEE Trans. On vehicular Tech, vol. 42, No. 4 pp.477-482, Nov 1993.*
- [6] Product News, "Lighting Intensity Dimmer System"(LIDS) by United Shenyan Intl Ltd.
- [7] <http://epsilon.nought.de/tutorials/fuzzy/fuzzy.pdf>
- [8] Lennart Ljung, "An Introduction to Fuzzy Control", NHI, 1992.
- [9] F. Martin Mcheill, Thro, Yager, "Fuzzy Logic- A Practical Approach", A.P., 1994.
- [10] Product News, "Automotive sensor to adjust the headlight for optimal illumination," Honeywell.
- [11] Das, S. and Bowles, B.A., "Simulations of highway chaos using fuzzy logic" 18th International Conference of the North American Fuzzy Information Processing Society, 1999, pp. 130 -133.
- [12] Peeta, S. and Yu, J.W. "Adaptability of a hybrid route choice model to incorporating driver behavior dynamics under information provision" *IEEE Transactions on Systems, Man and Cybernetics, Part A, 2004, pp. 243-256.*

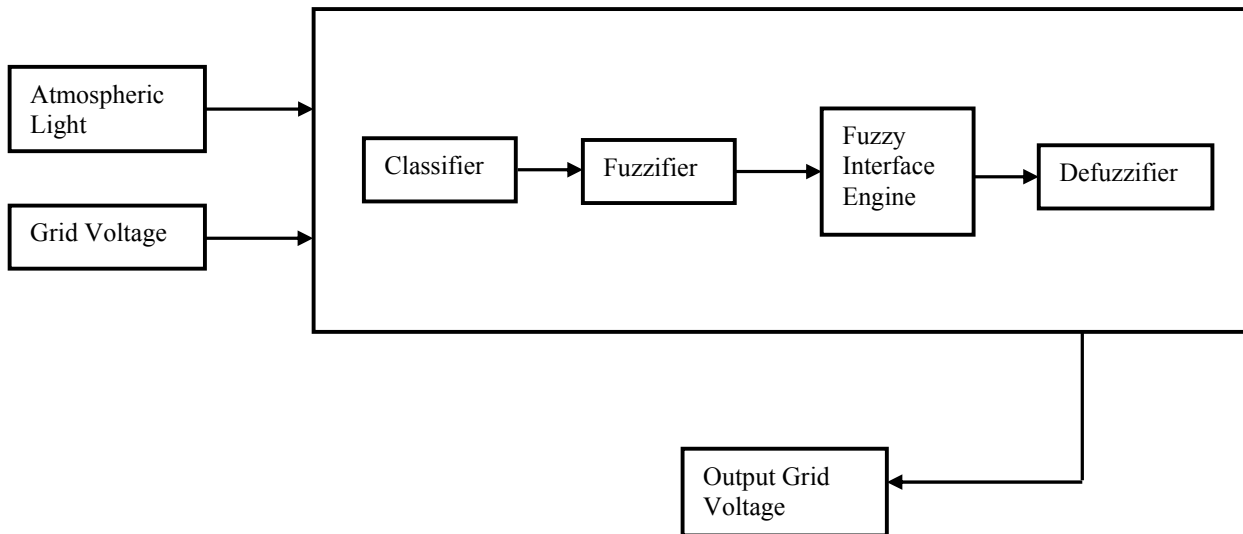

Fig. 1 Block diagram of fuzzy controller for controlling intensity of television screen

TABLE III
 RULES OF THE FUZZY CONTROLLER

Outside Light	Grid Voltage	Output grid Voltage
VERY DARK	VERY LOW	VERY LOW
DARK	LOW	VERY LOW
MEDIUM	MEDIUM	VERY LOW
BRIGHT	HIGH	VERY LOW
VERY BRIGHT	VERY HIGH	VERY LOW
VERY DARK	VERY LOW	LOW
DARK	LOW	LOW
MEDIUM	MEDIUM	LOW
BRIGHT	HIGH	LOW
VERY BRIGHT	VERY HIGH	LOW
VERY DARK	VERY LOW	MEDIUM
DARK	LOW	MEDIUM
MEDIUM	MEDIUM	MEDIUM
BRIGHT	HIGH	MEDIUM
VERY BRIGHT	VERY HIGH	MEDIUM
VERY DARK	VERY LOW	HIGH
DARK	LOW	HIGH
MEDIUM	MEDIUM	HIGH
BRIGHT	HIGH	HIGH
VERY BRIGHT	VERY HIGH	HIGH
VERY DARK	VERY LOW	VERY HIGH
DARK	LOW	VERY HIGH
MEDIUM	MEDIUM	VERY HIGH
BRIGHT	HIGH	VERY HIGH
VERY BRIGHT	VERY HIGH	VERY HIGH