

DCGA Based-Transmission Network Expansion Planning Considering Network Adequacy

H. Shayeghi, M. Mahdavi, H. Haddadian

Abstract—Transmission network expansion planning (TNEP) is an important component of power system planning that its task is to minimize the network construction and operational cost while satisfying the demand increasing, imposed technical and economic conditions. Up till now, various methods have been presented to solve the static transmission network expansion planning (STNEP) problem. But in all of these methods, the lines adequacy rate has not been studied after the planning horizon, i.e. when the expanded network misses its adequacy and needs to be expanded again. In this paper, in order to take transmission lines condition after expansion in to account from the line loading view point, the adequacy of transmission network is considered for solution of STNEP problem. To obtain optimal network arrangement, a decimal codification genetic algorithm (DCGA) is being used for minimizing the network construction and operational cost. The effectiveness of the proposed idea is tested on the Garver's six-bus network. The results evaluation reveals that the annual worth of network adequacy has a considerable effect on the network arrangement. In addition, the obtained network, based on the DCGA, has lower investment cost and higher adequacy rate. Thus, the network satisfies the requirements of delivering electric power more safely and reliably to load centers.

Keywords—STNEP Problem, Network Adequacy, DCGA.

I. INTRODUCTION

TRANSMISSION network expansion planning (TNEP) is a basic part of power system planning that determines where, when and how many new transmission lines should be added to the network. Its task is to minimize the network construction and operational cost, while meeting imposed technical, economic and reliability constraints. TNEP should be satisfied required adequacy of the lines for delivering safe and reliable electric power to load centers along the planning horizon [1-3]. Calculation of investment cost for network expansion is difficult because it is dependent on the various reliability criteria [4]. Thus, the long-term TNEP is a hard, large-scale combinatorial optimization problem. Transmission expansion planning is a hard and highly non-linear combinatorial optimization problem that generally, can be classified as static or dynamic. Static expansion determines where and how many new transmission lines should be added

H. Shayeghi is with the Department of Technical Eng., University of Mohaghegh Ardabili, Ardabil, Iran (corresponding author to provide phone: 98-551-2910; fax: 98-551-2904; e-mail: hshayeghi@gmail.com).

M. Mahdavi is with the Electrical Engineering Department, Zanjan University, Zanjan, Iran.

H. Haddadian is with the Electrical Engineering Department, Zanjan University, Zanjan, Iran.

to the network up to the planning horizon. If in the static expansion the planning horizon is categorized in several stages we will have dynamic planning [5, 6].

In the majority of power systems, generating plants are located far from the load centers. In addition, the planned new projects are still far from completion. Due to these factors, investment cost for transmission network is huge. Thus, the STNEP problem acquires a principal role in power system planning and should be evaluated carefully because any effort to reduce transmission system expansion cost significantly improves cost saving. After Garver's paper that was published in 1970 [7], much research has been done on the field of TNEP problem. Some of them such as [1-3,6,8-25] is related to problem solution method. Some others, proposed different approaches for solution of this problem considering various parameters such as uncertainty in demand [5], reliability criteria [4, 26, 27], and economic factors [28]. Also, some of them investigated this problem and generation expansion planning together [29, 30]. Recently, different methods such as GRASP [3], Bender decomposition [6], HIPER [17], branch and bound algorithm [31], sensitivity analysis [15], genetic algorithm [1, 11, 20], simulated annealing [16, 25] and Tabu search [12] have been proposed for the solution of STNEP problem. In all of these methods, the problem has been solved regardless to transmission network adequacy. In Ref. [8], authors proposed a neural network based method for solution of the TNEP problem with considering both the network losses and construction cost of the lines. But the transmission network adequacy has not been investigated in this study. In Ref. [10], the network expansion costs and transmitted power through the lines have been included in objective function and the goal is optimization of both expansion costs and lines loading. In addition, the objective function is different from those which are represented in [6, 11-12, 15-17, 20,31]. However, the transmission network adequacy has not been studied.

In Ref. [32], the voltage level of transmission lines has been considered as a subsidiary factor but its objective function only includes expansion and generation costs and one of the reliability criteria i.e.: power not supplied energy. Moreover, expansion planning has been studied as dynamic type and the network adequacy has not been considered. Finally, in pervious author's papers [33, 34], the expansion cost of substations with the network losses have been considered for the solution of STNEP problem. The results evaluation in [33] was shown that the network with considering higher voltage level save capital investment in the long-term and become overload later. In [34], it was shown that the total expansion cost of the network was calculated

more exactly considering effects of the inflation rate and load growth factor and therefore the network satisfies the requirements of delivering electric power more safely and reliably to load centers. However, the STNEP problem has not been solved considering the network adequacy.

The network adequacy is necessary to provide load demands when the network is expanding because its lack (i.e. lines overloading) caused to load interrupting. Consequently, if transmission lines of expanded network overloads later, the network satisfies the requirements of delivering electric power more safely and reliably to load centers. It is well-known that the transmission network adequacy correlates with the investment cost. i.e.: the network adequacy increases by rising investment cost and using the exact planning and the proper algorithm. On the other hand, with a low costing, the network operates weakly to support load demand and becomes overloaded early. Therefore, with compromising between two parameters, i.e. investment cost and network adequacy rate, static transmission network expansion planning can be implemented in order to have a network with maximum efficiency from the technical and economical viewpoint.

In this paper, transmission expansion planning has been studied by including the adequacy of transmission lines and expansion cost in objective function using decimal codification genetic algorithm (DCGA). It should be noted that with performing DC load flow according to load growth for years after expansion, if only a line of the network is overloaded in each year, network adequacy is missed. The best solution that obtains from DCGA is the configuration for network expansion which has a lower cost and higher adequacy that will be lately overloaded. Meanwhile the annual worth of network adequacy has a considerable effect on the obtained result. For this purpose the case study has received various amount of this parameter.

This paper is organized as follows: Objective function of the STNEP problem is represented in Sec. 2. Section 3 describes completely GA based proposed method and the chromosome structure for solution of the STNEP problem. The method of choosing selection, crossover and mutation operators and also the fitness function for solving the STNEP problem are given in Sec. 4 and Sec. 5 respectively. The characteristics of case study system and simulation results are illustrated in Sec. 6. Finally, in Sec. 7 conclusion is represented.

II. OBJECTIVE FUNCTION OF THE STNEP PROBLEM

The STNEP problem is a mixed-integer nonlinear optimization problem. Due to consideration of transmission lines condition after expansion from the loading viewpoint, the adequacy of transmission network is included in STNEP objective function. Therefore, the proposed objective function could be defined as follows:

$$OF = K + \sum_{i,j \in \Omega} C_{ij} n_{ij} - T_A C_A \quad (1)$$

Where:

C_{ij} : Construction cost of each line in branch i - j .

n_{ij} : Number of new circuits in corridor i - j .

Ω : Set of all corridors.

T_A : Required time for missing the expanded network adequacy (in year).

C_A : Annual worth of transmission network adequacy. (\$/year). Determination of this parameter is based on importance of network adequacy for network owners. Naturally, its high quantities lead to have a network with high adequacy and of course expensive configuration for expansion.

K : A constant parameter that is large enough to prevent obtaining negative values of objective function.

Several restrictions have to be modeled in a mathematical representation to ensure that the mathematical solutions are in line with the planning requirements. These constraints are as follows (see Refs. [5, 33] for more details):

$$Sf + g - d = 0 \quad (2)$$

$$f_{ij} - \gamma_{ij}(n_{ij}^0 + n_{ij})(\theta_i - \theta_j) = 0 \quad (3)$$

$$|f_{ij}| \leq (n_{ij}^0 + n_{ij}) \bar{f}_{ij} \quad (4)$$

$$0 \leq n_{ij} \leq \bar{n}_{ij} \quad (5)$$

$$0 \leq g \leq \bar{g} \quad (6)$$

$$N-1 \text{ Safe Criterion} \quad (7)$$

Where, $(i, j) \in \Omega$ and:

S : Branch-node incidence matrix.

f : Active power matrix in each corridor.

g : Generation vector.

d : Demand vector.

N : Number of network buses.

θ : Phase angle of each bus.

γ_{ij} : Total susceptance of circuits in corridor i - j .

n_{ij}^0 : Number of initial circuits in corridor i - j .

\bar{n}_{ij} : Maximum number of constructible circuits in corridor

i - j .

\bar{f}_{ij} : Maximum of transmissible active power through corridor i - j which will have two different rates according to voltage level of candidate line.

Ω : Set of all corridors

In this study, the objective function is different from those which are mentioned in [1-20], [23-28], [30, 31, 33, 34] and the goal is obtaining the number of required circuits for adding to the existed network so that it have been maximum adequacy and minimum investment cost during the specified horizon year. Thus, problem parameters of the problem are discrete time type and consequently the optimization problem is an integer programming problem. For the solution of this problem, there are various methods such as classic mathematical and heuristic methods [5-21]. In this study, the decimal codification genetic algorithm is used to solve the STNEP problem due to flexibility, simple implementation and the advantages which were mentioned in [33].

III. DCGA AND CHROMOSOME STRUCTURE OF THE PROBLEM

Standard genetic algorithm is a random search method that can be used to solve non-linear system of equations and optimize complex problems. The base of this algorithm is the selection of individuals. It doesn't need a good initial estimation for sake of problem solution, In other words, the

solution of a complex problem can be started with weak initial estimations and then be corrected in evolutionary process of fitness. The standard genetic algorithm manipulates the binary strings which may be the solutions of the problem. This algorithm can be used to solve many practical problems such as transmission network expansion planning [33, 34]. The genetic algorithm generally includes the three fundamental genetic operators of reproduction, crossover and mutation. These operators conduct the chromosomes toward better fitness. A new idea has been applied in the solution whose parameters are integer number for creating the chromosomes and operators performance that caused to increasing convergence speed and simplification. According to this idea, each chromosome is a set of non-minus integer numbers.

There are three methods for coding the transmission lines based on the genetic algorithm method [33, 34]:

- 1) Binary codification for each corridor.
- 2) Binary codification with independent bits for each line.
- 3) Decimal codification for each corridor.

Although binary codification is conventional in genetic algorithm but in here, the third method has been used due to following reasons [34]:

- 1) Avoiding difficulties which are happened at coding and decoding problem.
- 2) Preventing the production of completely different offspring from their parents and subsequent occurrence of divergence in mentioned algorithm.

In this method crossover can take place only at the boundary of two integer numbers. Mutation operator selects one of existed integer numbers in chromosome and then changes its value randomly. Reproduction operator, similar to standard form, reproduces each chromosome proportional to value of its objective function. Therefore, the chromosomes which have better objective functions will be selected more probable than other chromosomes for the next population (i.e., Elitism strategy).

In this work, each gene in the chromosome includes number of transmission circuits (the both of constructed and new circuits) at each corridor. Fig. 1 illustrates a typical chromosome with 12 corridors. Also, the flowchart of proposed approach has been represented in Fig. 2.

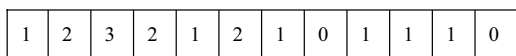

Fig. 1. A typical chromosome

Also, the flowchart of proposed approach has been represented in Fig. 2.

IV. SELECTION-CROSSOVER-MUTATION PROCESS

This operator selects the chromosome in the population for reproduction. The more fit the chromosome, the higher its probability of being selected for reproduction. Thus, selection is based on the survival-of-the-fittest strategy, but the key idea is to select the better individuals of the population, as in tournament selection, where the participants compete with each other to remain in the population. The most commonly used strategy to select pairs of individuals that has applied in this paper is the method of roulette-wheel selection. After

selection of the pairs of parent strings, the crossover operator is applied to each of these pairs.

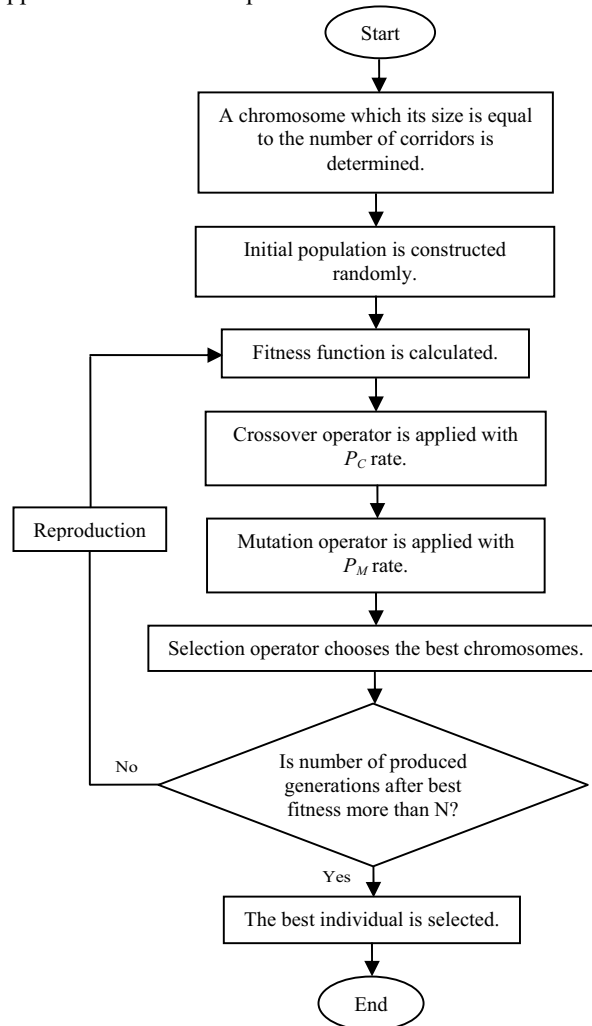

Fig. 2. Flowchart of the proposed method

The crossover operator involves the swapping of genetic material (bit-values) between the two parent strings. Based on predefined probability, known as crossover probability, an even number of chromosomes are chosen randomly. A random position is then chosen for each pair of the chosen chromosomes. The two chromosomes of each pair swap their genes after that random position. Crossover may be applied at a single position or at multiple positions. In this work, because of choosing smaller population multiple position crossover is used with probability of 0.9.

Each individuals (children) resulting from each crossover operation will now be subjected to the mutation operator in the final step to forming the new generation. The mutation operator enhances the ability of the GA to find a near optimal solution to a given problem by maintaining a sufficient level of genetic variety in the population, which is needed to make sure that the entire solution space is used in the search for the best solution. In a sense, it serves as an insurance policy; it helps prevent the loss of genetic material. This operator randomly flips or alters one or more bit values usually with very small probability known as a mutation probability

(typically between 0.001 and 0.01). In a binary coded GA, it is simply done by changing the gene from 1 to 0 or vice versa. In DCGA, as in this study, the gene value is randomly increased or decreased by 1 providing not to cross its limits. Practical experience has shown that in the transmission expansion planning application the rate of mutation has to be larger than ones reported in the literature for other application of the GA. In this work mutation is used with probability of 0.1 per bit.

After mutation, the production of new generation is completed and it is ready to start the process all over again with fitness evaluation of each chromosome. The process continues and it is terminated by either setting a target value for the fitness function to be achieved, or by setting a definite number of generations to be produced. In this study, a more suitable criteria termination has accomplished that is production of predefined generations after obtaining the best fitness and finding no better solution. In this work a maximum number of 2000 generations has chosen.

V. FITNESS FUNCTION CHOOSING

The fitness function is one of the key elements of GAs as it determines whether a given potential solution will contribute its elements to future generation through the selection process or not. Since the objective of GAs is to maximize the fitness, while the objective function of transmission planning model is to minimize the objective function (OF) as given by Eq. (1), therefore it is necessary to map the objective function onto the fitness function. The fitness function (Fit) adopted in this study is:

$$Fit = \frac{A}{OF} \quad (8)$$

A is considered 10^{12} as a system-dependent constant.

VI. RESULTS AND DISCUSSION

Garver's network is used as a test system to demonstrate the effectiveness of the proposed idea. The configuration of this network before expansion is shown in Fig. 3.

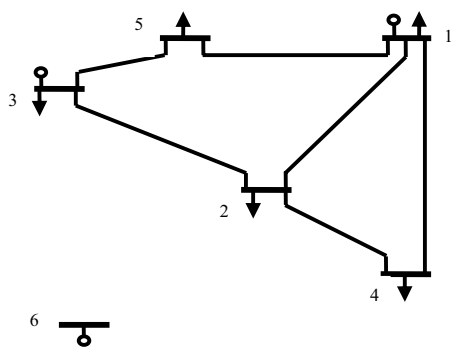

Fig. 3. Garver's 6-bus network

In this network, voltages and power capability of the existed lines are 230 kV and 400 MW. The length of possible corridors and construction cost of 230 kV lines have been given in Tables 1 and 2. Resistance and leakage reactance per kilometer of each line are 0.00012 and 0.0004, respectively. Substations 1, 3 and 6 are generator busses that their generation limit are 100 MW, 250 MW and 450 MW,

respectively. The load data has also given in Table 3. Load growth rate for greatest load centers (busses 2 and 4) is assumed 10%. The load growth rate of other load centers is proportional to their magnitude than the overall load of systems (e.g. annual increase of the 40 MW load is $40/240 \times 10\%$ i.e.: 1.67% and so on). For supplying load demands the capacity of generator busses increases as the same load growth rate. Finally the planning horizon year is 2013 (5 years ahead).

TABLE I
CONFIGURATION OF THE NETWORK

From bus	To bus	Length (Km)
1	2	100
1	3	95
1	4	150
1	5	60
1	6	170
2	3	55
2	4	110
2	5	65
2	6	75
3	4	155
3	5	50
3	6	120
4	5	157
4	6	85
5	6	160

TABLE II
CONSTRUCTION COST OF 230 kV LINES

Number of Line Circuits	Fix Cost of Line Construction ($\times 10^3$ dollars)	Variable Cost of Line Construction ($\times 10^3$ dollars)
1	546.5	45.9
2	546.5	63.4

TABLE III
ARRANGEMENT OF THE LOAD

Bus	Load (MW)	Bus	Load (MW)
1	80	4	160
2	240	5	240
3	40	6	0

As mentioned, because of importance of network adequacy worth (C_A), the DCGA based proposed method is carried out for different values of this parameter. Also, due to the stochastic nature of the GA, there is no guarantee that different executions of the program converge to the same solution. Thus, in addition to end condition which is mentioned in Sec. 4, the program was executed three times for each case to validate the stability of the algorithm. Finally, after running the program, for every scenario the results were the same indicating the robustness of GA to finding optimal solutions. Obtaining results for different values of C_A is given in Tables 4 to 7.

TABLE IV
PROPOSED CONFIGURATION AND COST FOR NETWORK EXPANSION WITH
RESPECT TO $C_A=1$ MILLION \$/YEAR

Corridor	Number of required circuits	Expansion cost
2-6	3	11.97 MSUS
Year of missing the network adequacy ($T_A + 1$): 6 years after the expansion (year 2019)		

TABLE V
PROPOSED CONFIGURATION AND COST FOR NETWORK EXPANSION WITH
RESPECT TO $C_A=1.5$ MILLION \$/YEAR

Corridor	Number of required circuits	Expansion cost
2-6	3	15.27 MSUS
1-5	1	
Year of missing the network adequacy ($T_A + 1$): 9 years after the expansion (year 2022)		

TABLE VI
PROPOSED CONFIGURATION AND COST FOR NETWORK EXPANSION WITH
RESPECT TO $C_A=2$ MILLION \$/YEAR

Corridor	Number of required circuits	Expansion cost
2-6	3	18.57 MSUS
1-5	2	
Year of missing the network adequacy ($T_A + 1$): 11 years after the expansion (year 2024)		

TABLE VII
PROPOSED CONFIGURATION AND COST FOR NETWORK EXPANSION WITH
RESPECT TO $C_A=2.5$ MILLION \$/YEAR

Corridor	Number of required circuits	Expansion cost
2-6	3	23.7 MSUS
1-5	2	
1-2	1	
Year of missing the network adequacy ($T_A + 1$): 13 years after the expansion (year 2026)		

It can be seen that the annual worth of network adequacy has a nonlinear relationship with network expansion cost. The results, as shown in Table 2, relatively give a better solution from the technical (network adequacy) and economical (expansion cost) viewpoint. Thus, there should be a trade-off between the desired level of adequacy, network losses and capital investment of network owners. But it seems that relatively lower investment cost can be given a reasonable adequacy for transmission network.

VII. CONCLUSION

In this paper, by including the transmission network adequacy in the objective function of STNEP, an optimal network arrangement is obtained for the network expansion using a decimal coded genetic algorithm (DCGA) method. The proposed arrangement satisfies a maximum adequacy for the feeding of loads with minimum network expansion cost.

Increasing the annual worth of network adequacy is caused more lines added to network for expansion and subsequent the network satisfies the requirement of delivering electric power more safely and reliably to load centers. The solution of the STNEP problem using the DCGA method for various quantities of network adequacy worth shows that the annual worth of network adequacy has a nonlinear direct relationship with network expansion cost and therefore a trade-off between the desired level of network adequacy and capital investment of network owners is required. Thus, it can be said that the solution of the TNEP by relatively lower investment cost can lead to an expansion design with a reasonable network adequacy. Also, regarding the fact that any paper has not been considered the network adequacy in transmission network expansion planning until now, implementation of this research by other solution methods and comparing it with proposed methods will be our further works.

APPENDIX

A. GA and other required data

Load growth coefficient = 1.07

Number of initial population = 5

End condition: 1500 iteration after obtaining best fitness (N=2000).

REFERENCES

- [1] A. R. Abdelaziz, Genetic algorithm-based power transmission expansion planning, *Proc. the 7th IEEE International Conference on Electronics, Circuits and Systems*, Jounieh, Vol. 2, December 2000, pp. 642-645.
- [2] V. A. Levi, M. S. Calovic, Linear-programming-based decomposition method for optimal planning of transmission network investments, *IEEE Proc. Generation, Transmission and Distribution*, Vol. 140, No. 6, 1993, pp. 516-522.
- [3] S. Binato, G. C. de Oliveira, J. L. Araujo, A greedy randomized adaptive search procedure for transmission expansion planning, *IEEE Trans. Power Systems*, Vol. 16, No. 2, 2001, pp. 247-253.
- [4] J. Choi, T. Mount, R. Thomas, Transmission system expansion plans in view point of deterministic, probabilistic and security reliability criteria, *Proc. the 39th Hawaii International Conference on System Sciences*, Hawaii, Vol. 10, Jan. 2006, pp. 247b-247b.
- [5] I. D. J. Silva, M. J. Rider, R. Romero, C. A. Murari, Transmission network expansion planning considering uncertainty in demand, *Proc. 2005 IEEE Power Engineering Society General Meeting*, Vol. 2, pp. 1424-1429.
- [6] S. Binato, M. V. F. Pereira, S. Granville, A new Benders decomposition approach to solve power transmission network design problems, *IEEE Trans. Power Systems*, Vol. 16, No. 2, 2001, pp. 235-240.
- [7] L. L. Garver, Transmission net estimation using linear programming, *IEEE Trans. Power Apparatus and Systems*, Vol. PAS-89, No. 7, 1970, pp. 1688-1696.
- [8] T. Al-Saba, I. El-Amin, The application of artificial intelligent tools to the transmission expansion problem, *Electric Power Systems Research*, Vol. 62, No. 2, 2002, pp. 117-126.
- [9] R. Chaturvedi, K. Bhattacharya, J. Parikh, Transmission planning for Indian power grid: a mixed integer programming approach, *International Trans. Operational Research*, Vol. 6, No. 5, 1999, pp. 465-482.
- [10] J. Contreras, F. F. Wu, A kernel-oriented algorithm for transmission expansion planning, *IEEE Trans. Power Systems*, Vol. 15, No. 4, 2000, pp. 1434-1440.
- [11] R. A. Gallego, A. Monticelli, R. Romero, Transmission system expansion planning by an extended genetic algorithm, *IEEE Proc. Generation, Transmission and Distribution*, Vol. 145, No. 3, 1998, pp. 329-335.

- [12] R. A. Gallego, R. Romero, A. J. Monticelli, Tabu search algorithm for network synthesis, *IEEE Trans. Power Systems*, Vol. 15, No. 2, 2000, pp. 490-495.
- [13] K. J. Kim, Y. M. Park, K. Y. Lee, Optimal long-term transmission expansion planning based on maximum principle, *IEEE Trans. Power Systems*, Vol. 3, No. 4, 1988, pp. 1494-1501.
- [14] G. Liu, H. Sasaki, N. Yorino, Application of network topology to long range composite expansion planning of generation and transmission lines, *Electric Power Systems Research*, Vol. 57, No. 3, 2001, pp. 157-162.
- [15] M. V. F. Periera, L. M. V. G. Pinto, Application of sensitivity analysis of load supplying capacity to interactive transmission expansion planning, *IEEE Trans. Power Apparatus and Systems*, Vol. PAS-104, 1985, pp. 381-389.
- [16] R. Romero, R. A. Gallego, A. Monticelli, Transmission system expansion planning by simulated annealing, *IEEE Trans. Power Systems*, Vol. 11, No. 1, 1996, pp. 364-369.
- [17] R. Romero, A. Monticelli, A hierarchical decomposition approach for transmission network expansion planning, *IEEE Trans. Power Systems*, Vol. 9, No. 1, 1994, pp. 373-380.
- [18] R. Romero, A. Monticelli, A zero-one implicit enumeration method for optimizing investments in transmission expansion planning, *IEEE Trans. Power Systems*, Vol. 9, No. 3, 1994, pp. 1385-1391.
- [19] H. Samarakoon, R. M. Shrestha, O. Fujiwara, A mixed integer linear programming model for transmission expansion planning with generation location selection, *Electrical Power and Energy Systems*, Vol. 23, No. 4, 2001, pp. 285-293.
- [20] E. L. da Silva, H. A. Gil, J. M. Areiza, Transmission network expansion planning under an improved genetic algorithm, *IEEE Trans. Power Systems*, Vol. 15, No. 3, 2000, pp. 1168-1174.
- [21] R. Teive, E. L. Silva, L. G. S. Fonseca, A cooperative expert system for transmission expansion planning of electrical power systems, *IEEE Trans. Power Systems*, Vol. 13, No. 2, 1998, pp. 636-642.
- [22] J. Yen, Y. Yan, J. Contreras, P. C. Ma, F. F. Wu, Multi-agent approach to the planning of power transmission expansion, *Decision Support Systems*, Vol. 28, No. 3, 2000, pp. 279-290.
- [23] N. Alguacil, A. L. Motto, A. J. Conejo, Transmission expansion planning: a mixed-integer LP approach, *IEEE Trans. Power Systems*, Vol. 18, No. 3, 2003, pp. 1070-1077.
- [24] A. M. L. da Silva, S. M. P. Ribeiro, V. L. Arienti, R. N. Allan, M. B. D. C. Filho, Probabilistic load flow techniques applied to power system expansion planning, *IEEE Trans. Power Systems*, Vol. 5, No. 4, 1990, pp. 1047-1053.
- [25] R. A. Gallego, A. B. Alves, A. Monticelli, R. Romero, Parallel simulated annealing applied to long term transmission network expansion planning, *IEEE Trans. Power Systems*, Vol. 12, No. 1, 1997, pp. 181-188.
- [26] R. S. Chanda, P. K. Bhattacharjee, A reliability approach to transmission expansion planning using fuzzy fault-tree model, *Electric Power Systems Research*, Vol. 45, No. 2 1998, pp. 101-108.
- [27] R. S. Chanda, P. K. Bhattacharjee, A reliability approach to transmission expansion planning using minimal cut theory, *Electric Power Systems Research*, Vol. 33, No. 2, 1995, pp. 111-117.
- [28] N. H. Sohtaoglu, The effect of economic parameters on power transmission planning, *IEEE Trans. Power Systems*, Vol. 13, 1998, pp. 941-945.
- [29] B. Graeber, Generation and transmission expansion planning in southern Africa, *IEEE Trans. Power Systems*, Vol. 14, 1999, pp. 983-988.
- [30] M. S. Kandil, S. M. El-Debeiky, N. E. Hasanien, Rule-based system for determining unit locations of a developed generation expansion plan for transmission planning, *IEE Proc. Generation, Transmission and Distribution*, Vol. 147, No. 1, 2000, pp. 62-68.
- [31] S. T. Y. Lee, K. L. Hocks, H. Hnyilicza, Transmission expansion of branch and bound integer programming with optimal cost capacity curves, *IEEE Trans. Power Apparatus and Systems*, Vol. PAS-93, No. 7, 1970, pp. 1390-1400.
- [32] A. S. D. Braga, J. T. Saraiva, A multiyear dynamic approach for transmission expansion planning and long-term marginal costs computation, *IEEE Trans. Power Systems*, Vol. 20, No. 3, 2005, pp. 1631-1639.
- [33] S. Jalilzadeh, A. Kazemi, H. Shayeghi, M. Mahdavi, Technical and economic evaluation of voltage level in transmission network expansion planning using GA, *Energy Conversion and Management*, Vol. 49, No. 5, May 2008, pp. 1119-1125.
- [34] H. Shayeghi, S. Jalilzadeh, M. Mahdavi, H. Haddadian, Studying influence of two effective parameters on network losses in transmission expansion planning using DCGA, *Energy Conversion and Management*, Vol. 49, No. 11, 2008, pp. 3017-3024.