

Image Transmission via Iterative Cellular-Turbo System

Ersin Gose, Kenan Buyukatak, Onur Osman, and Osman N. Ucan

Abstract—To compress, improve bit error performance and also enhance 2D images, a new scheme, called Iterative Cellular-Turbo System (IC-TS) is introduced. In IC-TS, the original image is partitioned into $2N$ quantization levels, where N is denoted as bit planes. Then each of the N -bit-plane is coded by Turbo encoder and transmitted over Additive White Gaussian Noise (AWGN) channel. At the receiver side, bit-planes are re-assembled taking into consideration of neighborhood relationship of pixels in 2-D images. Each of the noisy bit-plane values of the image is evaluated iteratively using IC-TS structure, which is composed of equalization block; Iterative Cellular Image Processing Algorithm (ICIPA) and Turbo decoder. In IC-TS, there is an iterative feedback link between ICIPA and Turbo decoder. ICIPA uses mean and standard deviation of estimated values of each pixel neighborhood. It has extra-ordinary satisfactory results of both Bit Error Rate (BER) and image enhancement performance for less than -1 dB Signal-to-Noise Ratio (SNR) values, compared to traditional turbo coding scheme and 2-D filtering, applied separately. Also, compression can be achieved by using IC-TS systems. In compression, less memory storage is used and data rate is increased up to $N-1$ times by simply choosing any number of bit slices, sacrificing resolution. Hence, it is concluded that IC-TS system will be a compromising approach in 2-D image transmission, recovery of noisy signals and image compression.

Keywords—Iterative Cellular Image Processing Algorithm (ICIPA), Turbo Coding, Iterative Cellular Turbo System (IC-TS), Image Compression.

I. INTRODUCTION

IN 1993, a French research group presented a new “parallel concatenated” coding scheme called Turbo codes [1]-[2]. These codes are capable of achieving a bit error rate of 10^{-5} at a channel signal-to-noise ratio (SNR) which is only 0.7 dB away from capacity, an improvement of almost 2 dB compared to the best previously known codes. More recently, much research has been done on the structure and performance of this new coding scheme. In this paper, it is studied that the application of Turbo codes to the robust transmission of 2-D images over noisy channels. The constraints on bandwidth, power, and time in many image

communication systems prohibit transmission of uncompressed raw image data. Compressed image representation, however, is very sensitive to bit errors, which can severely degrade the quality of the image at the receiver. Therefore, application of a channel code is required before transmission over noisy channels. In [3], an image transmission system was described which uses a rate $1/2$ convolutional code with constraint length 7 to protect the compressed images.

In this paper, a new iterative image processing algorithm is introduced and denoted as “Iterative Cellular Image Processing Algorithm” (ICIPA). The new unsupervised iterative algorithm uses the advantage of stochastic properties and neighborhood relations between the cells of the input image. In ICIPA scheme; first regarding to the stochastic properties of the data, all possible quantization levels are determined and then 2D input image is processed using a function, based on averaging and neighborhood relationship, and after that a parameter is assigned to each cell. Then Gaussian probability values are mapped to each cell regarding to all possible quantization levels and the attended value of the parameter. A maximum selector defines the highest probability value for each cell. In the case of complex data, first iteration output is fed into input till a sufficient output is found [4].

The performance of IC-TS is investigated over Additive White Gaussian Noise (AWGN) channel. In IC-TS, binary correspondence of each pixel amplitude value is grouped in bit-planes. Then these bit planes are transmitted and at the receiver side, a combined structure, denoted as ICIPA-Turbo decoder is employed. ICIPA-Turbo decoder is an iterative structure with a feedback link from the second Turbo decoder and ICIPA filtering. The decoding process continues iteratively till the desired output is obtained. The advantage of neighborhood relation of pixels is taken into account in IC-TS scheme, resulting improvement of image enhancement.

This paper is organized as: In Section II, system model is composed of Bit plane Slicing/Re-assembling, the Recursive Systematic Convolutional (RSC) Encoders, Iterative Cellular Image Processing Algorithm (ICIPA) and Turbo Decoding Process. Simulation results and the error performance of proposed scheme are presented in Section III. Section IV discusses the proposed method and concludes the paper.

II. SYSTEM MODEL

The system consists of image slicer, turbo encoder (transmitter), ICIPA, turbo decoder (receiver), and image

E. Gose is with the Department of Electronics Engineering, Turkish Air Force Academy, 34149, Istanbul, Turkey (corresponding author e-mail: e.gose@hho.edu.tr).

K. Buyukatak is with the Department of Electronics Engineering, Turkish Air Force Academy, 34149, Istanbul, Turkey (e-mail: k.buyukatak@hho.edu.tr).

O. Osman is with the Department of Electric and Electronics Engineering, Arel University, 34295, Istanbul, Turkey (e-mail: oosman@arel.edu.tr).

O. N. Ucan is with the Department of Electric and Electronics Engineering, Istanbul University, 34320, Istanbul, Turkey (e-mail: oosman@istanbul.edu.tr).

combiner sections as shown in Fig.1. In IC-TS, binary correspondence of each pixel amplitude value is grouped in bit-planes. Then these bit planes are transmitted and at the receiver side, a combined structure, denoted as ICIPA-Turbo decoder is employed. ICIPA-Turbo decoder is an iterative structure with a feedback link from the second Turbo decoder and ICIPA filtering. The decoding process continues iteratively till the desired output is obtained. The advantage of neighborhood relation of pixels is taken into account in IC-TS scheme, resulting improvement of image enhancement. Although each bit slice is transmitted in serial way, the bit string is reassembled at the receiver to preserve the original neighborhood matrix properties before decoding process. Thus instead of classical serial bit stream communication and decoding, in the proposed scheme, the coordinates of the pixels are kept as in their original input data matrix. Each pixel value is mapped to corresponding binary N-level and their binary correspondences are mapped regarding to the quantization of the transmitted bit slices.

In IC-TS, data rate can be increased up to (N-1) times, by only transmitting most important significant bit. Especially in quick search, such interesting results get importance. Thus proposed bit slicing can be also an efficient way of compression technique. To obtain more accurate 2D images, other bits can also be transmitted. Maximum resolution is obtained if all the bit slices from most significant to least significant are decoded at the receiver side without sacrificing resolution. As seen in Fig. 2, IC-TS output for each bit plane carries some part of the information

At the receiver, after each bit slice is decoded and hard decision outputs are formed, then all bit slice plane outputs are reassembled as first bit from the first bit slice, second bit from the second bit plane, the most significant bit from the last bit slice. Then these binary sequences are mapped to corresponding amplitude value of the pixel. In the case of compression, due to the resolution, not all the bits but some of them can be taken into account and corresponding quantized amplitude values of the pixels are found. Thus, it is concluded that, in IC-TS both BER, image enhancement can be achieved in comparison to classical separately turbo decoding and filtering. By this way, compression is achieved. Thus by sacrificing resolution, less memory storage is used and data rate is increased up to (N-1) times by simply choosing any number of bit slices. In compression, resolution loss is a general case.

For experimental results, a sample image with 150x150 pixel resolution with 16-gray level is taken. The problem is to transmit the image that is extracted from the image resources, to the processing stations (ground stations, airplanes, ship etc.). While transmitting, it is generally corrupted due to transmission conditions [5]-[7]. So it is needed to minimize the noise effects. Due to the fact that binary Turbo codes

accept only binary inputs, the image must be converted to binary fashion first and then coded before transmission. The solution is found as using "bit planes" [8]. While the plane symbols are being transmitted, they are corrupted with distorted channel, which is generally to be AWGN. At the receiver side, before MAP based decoding, the noise reduction is done in order to obtain the highest probability of the symbols. The basic idea in Turbo scheme is that two or more a posteriori probability decoders exchange soft information. One of the decoders calculates the a posteriori probability distribution of the bit planes and passes this information to the next decoder. The new decoder uses this information and computes its own version of the probability distribution. This exchange of information is called iteration. After a certain number of iterations, a decision is made at the second decoder. For each iteration, the probability that is decoded in favor of the correct decision of each bit of the planes will improve. At the last iteration, the hard decision is made using the soft decision of the last decoder.

The decoder employs two identical systematic recursive convolutional encoders (RSC) connected in parallel with an interleaver preceding the second recursive convolutional encoder. Both RSC encoders encode the information bits of the bit slices. The first encoder operates on the input bits in their original order, while the second one operates on the input bits as permuted by the interleaver. The decoding algorithm involves the joint Estimation of two Markov processes one for each constituent code. Because the two Markov processes are defined by the same set of data, the estimated data can be refined by sharing information between the two decoders in an iterative fashion. The output of one decoder can be used as a priori information by the other decoder. The iteration process is done until the outputs of the individual decoders are in the form of hard bit decisions. In this case, there is not any advantage to share information anymore.

A. Bit plane Slicing/ Re-assembling

Highlighting the contribution made to the total image appearance by specific bit plays an important role for IC-TS system. An application of this technique is also for data compression in the image processing area. Imagine that the image is composed of N-1 bit planes, ranging from plane 0 for least significant bit to plane N-1 for the most significant bit. In terms of N-bit planes, plane 0 contains all the lowest order bits in the bytes comprising the pixels in the image and plane N-1 contains all the high-order bits. In other words Plane zero is the Least Significant Bit (LSB) and Plane N-1 is the Most Significant Bit (MSB). Fig. 2 illustrates N Bit-plane decomposition of an image.

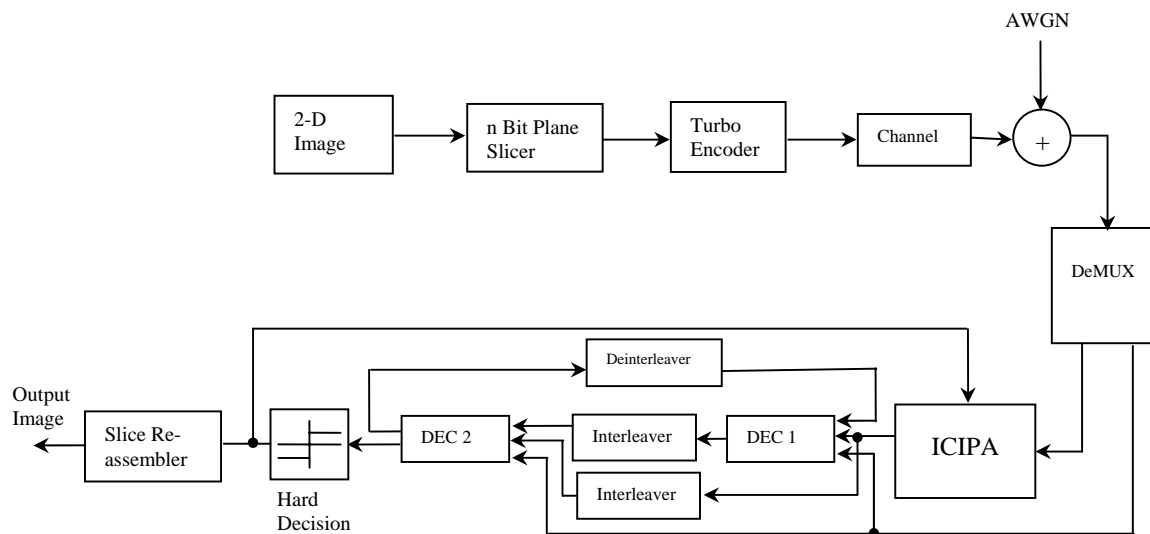

Fig. 1 IC-TS system model

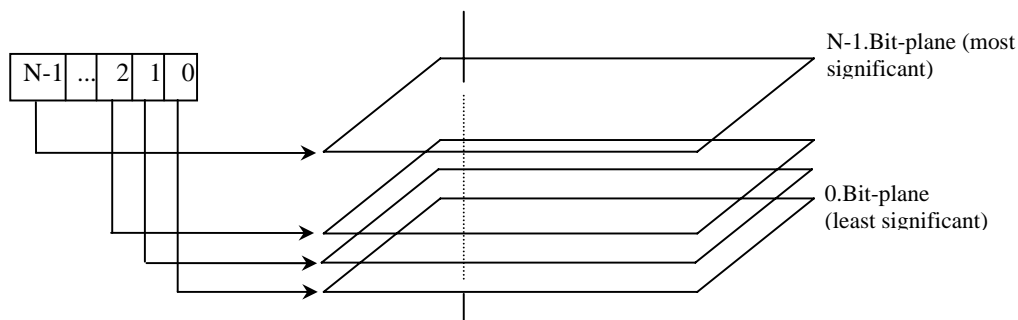

Fig. 2 N Bit-plane decomposition of an image

This decomposition reveals that only some highest order bits contain visually significant data. Also, note that plane $N-1$ corresponds exactly with an image threshold at gray-level 2^{N-1} . Fig. 3 shows the various bit planes for the image whose all the pixels are represented by 4 bits (i.e. $N=3$). In that case, $2^{3-1} = 4$ bit planes are observed. Note that only the three highest order bits contain visually significant data.

Bit plane combining is the reverse process of the slicing. The planes are recombined in order to reconstruct the image. But it is not needed to take into consideration all the slice contributions. For the importance of data rate, some planes can be ignored until the changes in gray level have an acceptable impact on the image. This approach will increase the data rate. Fig. 3 shows how the combinations of the slices contribute to recovery of the image.

In this study, the image is sliced to 4 planes i.e. each pixel in the image is represented by 4 bits (or 16 gray levels).

Imagine that the image is composed of four 1-bit planes, ranging from plane 0 for the least significant bit to plane 3 for the most significant bit. In terms of 4-bit bytes, plane 0 contains all the lowest order bits in the bytes comprising the pixels in the image and plane 3 contains all the high-order bits. Note that the most significant bit plane contains visually significant data. The other bit planes contribute to more subtle details in the image plane 3 corresponds exactly with an image thresholded at gray level 8.

Transforming the image in a binary fashion is very suitable before transmission. If the image have been considered without being sliced, then the neighborhood relationship would have been lost. So, it would be useless to have a wiener filter at the receiver side and hence the performance of the proposed system would be the same as that of the other conventional techniques. When the image is sliced first and then coded and transmitted, the neighborhood properties

would be evaluated. As a result, the noise effect would be reduced before MAP algorithm, so the performance is significantly improved.

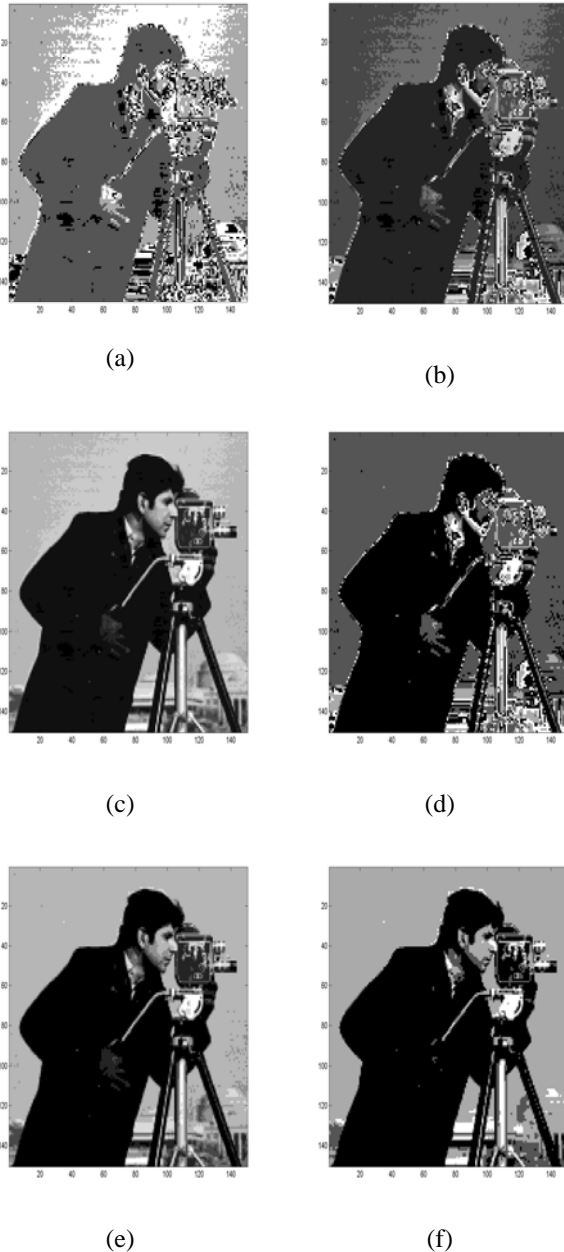

Fig. 3 The effects of the various slice combinations

- (a) 0.Bit Plane+1.Bit plane
- (b) 0.Bit Plane+1.Bit plane+2.Bit plane
- (c) 0.Bit Plane+1.Bit plane+2.Bit plane+3.Bit plane
- (d) 1.Bit plane+2.Bit plane
- (e) 1.Bit Plane+2.Bit plane+3.Bit plane
- (f) 2.Bit plane+3.Bit plane

B. The Recursive Systematic Convolutional (RSC) Encoders

In this section, general information is given about Recursive Systematic Convolutional (RSC) codes, which will be used in the study. Consider a half-rate RSC encoder with M memory size. If the d_k is an input at time k, the output X_k is equal,

$$X_k = d_k \quad (1)$$

Remainder $r(D)$ can be found using feedback polynomial $g^{(0)}(D)$ and feed forward polynomial $g^{(1)}(D)$. The feedback variable is,

$$r_i = d_k + \sum_{j=1}^K r_{k-j} g_j^{(0)} \quad (2)$$

and RSC encoder output Y_k which called parity data [5],[6] is

$$Y_k = \sum_{j=0}^K r_{k-j} g_j^{(1)} \quad (3)$$

RSC encoder with memory M=2 and rate R=1/2 which feedback polynomial $g^{(0)} = 7$, feed forward polynomial $g^{(1)} = 5$ and it has a generator matrix

$$G(D) = \begin{bmatrix} 1 & \frac{1+D+D^2}{1+D^2} \end{bmatrix} \quad (4)$$

where D is memory unit.

C. ICIPA Applied to Bit Planes

In this section, a new iterative image processing algorithm is introduced and denoted as "Iterative Cellular Image Processing Algorithm" (ICIPA). The new unsupervised iterative algorithm uses the advantage of stochastic properties and neighborhood relations between the cells of the input image. In ICIPA scheme; first regarding to the stochastic properties of the data, all possible quantization levels are determined and then 2D input image is processed using a function, based on averaging and neighborhood relationship and after that, a parameter P is assigned to each cell. Then Gaussian probability values are mapped to each cell regarding to all possible quantization levels and the attended value P . A maximum selector defines the highest probability value for each cell. In the case of complex data, first iteration output is fed into input until a sufficient output is found.

This algorithm has iterative and cellular characteristics. First of all, neighborhood parameters in matrix P are computed. For a cell, the output values of the neighbor cells, $P_{i,j}$, are

multiplied by some weights, summed and then averaged according to the weights. This can be formulized for the first level neighborhood of any N^{th} bit plane as,

$$C_{i,j}^{(t)} = \frac{1}{\left(1 + \sum_{z=1}^b \frac{8}{z}\right)} \sum_{k=i-b}^{i+b} \sum_{l=j-b}^{j+b} \left(\frac{1}{\text{Max}(|k-i|, |l-j|)} \right)^2 \cdot C_{k,l}^{(t-1)} \quad (5)$$

Here i and j are row and column indexes, t is iteration index, b is the level of neighborhood which effects the cell and maximum is an operator which finds out the maximum of the values in the parenthesis in the case of the conditions below.

$$\text{Max}(|k-i|, |l-j|) = \begin{cases} |k-i| & \text{if } |k-i| \geq |l-j| \text{ and } |k-i| \neq 0, \\ |l-j| & \text{if } |l-j| \geq |k-i| \text{ and } |l-j| \neq 0, \\ 1 & \text{if } |k-i| = |l-j| = 0 \end{cases} \quad (6)$$

b can take any integer value and this designates the neighborhood dimension. At the first iteration ($t=1$), $P^{(t-1)}$ indicates the cells of the input image. Level of neighborhood and this effect can be shown as,

$$w_z = \left(\frac{1}{z}\right)^2, \quad z = 1 \dots m \quad (7)$$

Before calculating the color probability of the cells, quantization levels are obtained from the image according to the color level. These quantization levels are chosen from the colors which are mostly encountered in the image. To calculate the color probability of the cells, logarithmic form of Gaussian probability is used. Weighted average is computed before calculating the color probability of the cells. Quantization levels are obtained from the image according to the color level. These quantization levels are chosen from the colors which are encountered in the image. The color probability of the cells is defined as,

$$\Pr(P_{i,j}^{(t)} = q_l) = -\frac{(P_{i,j}^{(0)})^2}{2\sigma^2} - \frac{(P_{i,j}^{(t)} - q_l)^2}{2\sigma^2} \quad (8)$$

Here l is quantization index, q_l shows the quantization or color level and σ^2 is the variance of the noise. Then, maximum probabilities are chosen and hence, pixel color is set.

D. Turbo Decoding Process

Only MAP based decoding is considered. The goal of the MAP algorithm is to find the a posteriori probability of each state transition, message bit, or code symbol produced by the

underlying Markov process, given the noisy observation y [9]-[11].

Once the a posteriori probabilities are calculated for all possible values of the desired quantity, a hard decision is made by taking the quantity with the highest probability. When used for turbo decoding, The MAP algorithm calculates the a posteriori probabilities of the message bits for the filtered planes, which are then put into Log-Likelihood Ratio (LLR) form [12]. Before finding the a posteriori probabilities for the message bits, the MAP algorithm first finds the probability of each valid state transition given the noisy channel observation y .

III. SIMULATION RESULTS

In this section, simulation results are presented that illustrate the performance of the proposed (IC-TS) algorithm over the transmitted image. In simulation, $\frac{1}{2}$ rate RSC encoder with AWGN channel model is used. Here the generator matrix is $g=[111:101]$, a random interleaver is applied and the frame size is chosen as $N=150$. Iteration number (between ICIPA and decoder) is taken 1. At first, the pixels of the image are converted to 16 gray levels and then sliced to four bit-planes. All planes are then coded via RSC encoder and a random interleaver. The coded planes are corrupted with SNR=-3dB, -1dB and 1dB and transmitted. Fig. (4-6) show the corrupted, traditional turbo processed, ICIPA processed and reconstructed images via IC-TS system.

The results have shown that, to recover the corrupted image at 1 dB SNR or below, the well known image-processing and conventional Turbo algorithms are not satisfactory as seen in Fig. (4-6). The proposed IC-TS algorithm gives good results from -3 dB SNR to 2 dB as shown in Fig. 7. This is a challenging result and we have at least 3.5 dB additional SNR improvement compared to that of classical image processing and conventional turbo coding systems. Also, in Fig. 7, the BER of 1^{st} plane is better than that of the 0^{th} bit plane. The BER of 2^{nd} bit is better than 0^{th} and 1^{st} bit planes. This is an expected result, since the neighborhood relations of 2^{nd} bit plane are more than 0^{th} and 1^{st} bit planes. At 0 dB SNR, the BER of 0^{th} bit plane of the proposed IC-TS system is same as that of conventional turbo system. Above 0 dB SNR, the performance of 0^{th} bit plane of the proposed IC-TS system becomes worse. But due to the fact that the 0^{th} bit plane is the least significant bit plane and contains visually less significant data in general, the resulting recovered image is still satisfactory. The performance of 3^{rd} bit plane is superior to the performance of the other bit planes. For example, performance of 3^{rd} bit plane at 1.2 dB approaches BER of 10^{-3} .

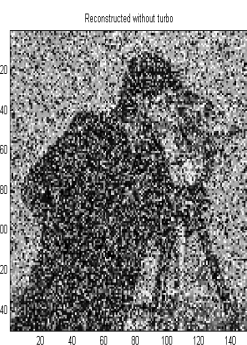

(a)

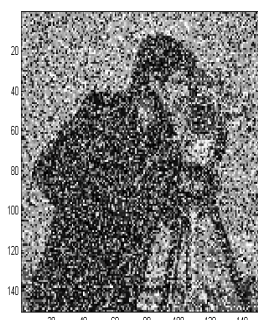

(b)

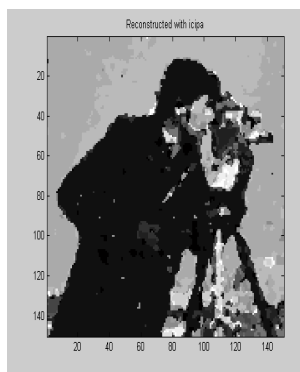

(c)

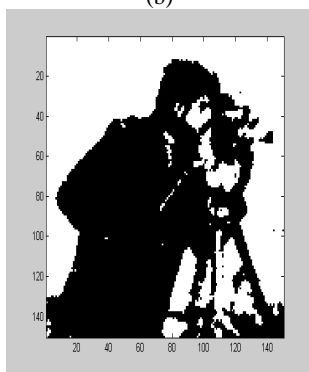

(d)

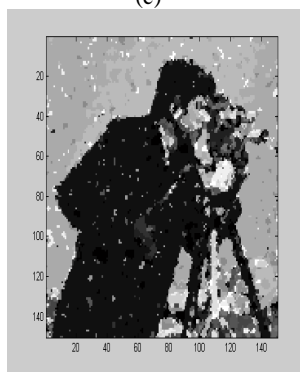

(e)

Fig. 4 Noisy 2D image and various simulation results for SNR=-3dB

- (a) Corrupted image with SNR=-3dB
- (b) Turbo processed image
- (c) ICIPA processed image
- (d) Most significant part of IC-TS output
- (e) IC-TS processed image

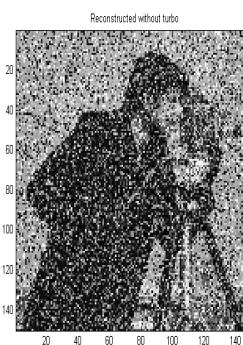

(a)



(b)

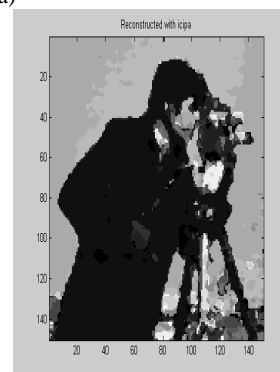

(c)



(d)



(e)

Fig. 5 Noisy 2D image and various simulation results for SNR=-1dB

- (a) Corrupted image with SNR= -1dB
- (b) Turbo processed image
- (c) ICIPA processed image
- (d) Most significant part of IC-TS output
- (e) IC-TS processed image

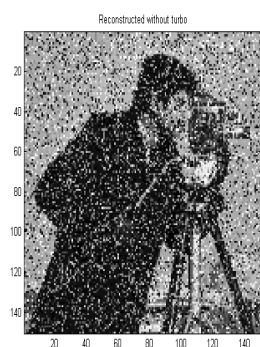

(a)



(b)

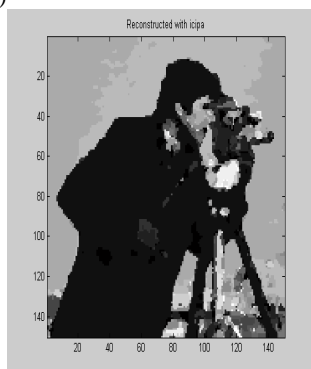

(c)



(d)

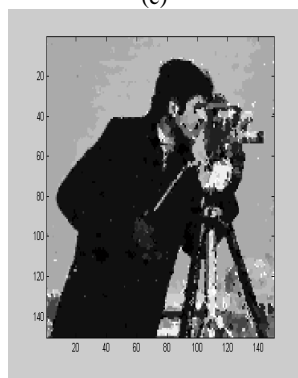

(e)

Fig. 6 Noisy 2D image and various simulation results for SNR=1dB

- (a) Corrupted image with SNR=1dB
- (b) Turbo processed image
- (c) ICIPA processed image
- (d) Most significant part of IC-TS output
- (e) IC-TS processed image

As a result, obtaining good results depend on the local neighborhood relations of the planes. Increasing the number of the bit planes enables to study with more detailed images. If the image does not have detail information, it is no need to increase the number of the bit planes. To increase the number of the bit planes means to improve the complexity. In Fig. (4d-6d), it is clearly seen that it is possible to extract main characteristics of original image from most significant part of IC-TS output.

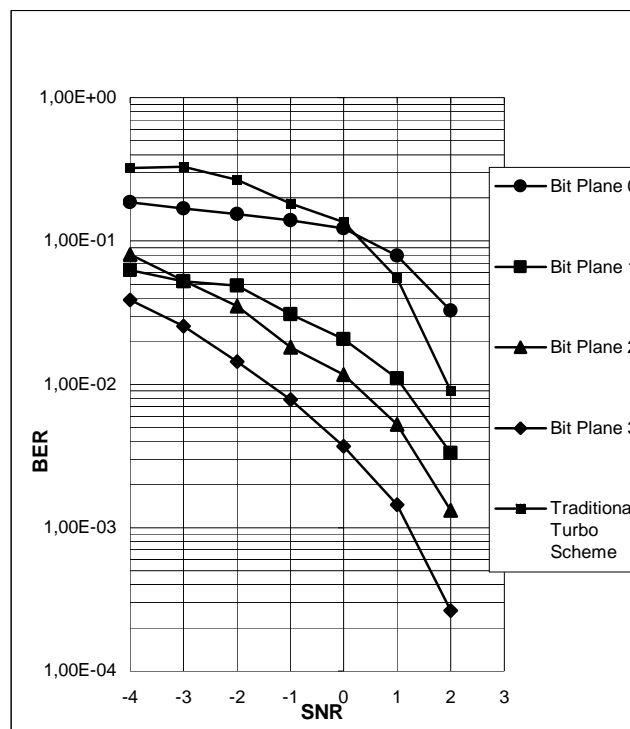

Fig. 7 Bit error performance of conventional Turbo and IC-TS with various bit planes

IV. CONCLUSIONS

The images being transmitted over noisy channels are extremely sensitive to the bit errors, which can severely degrade the quality of the image at the receiver. This necessitates the application of error control codes in the image transmission. This study presents an efficient image transmission by means of a new proposed IC-TS (Iterative Cellular-Turbo System) method, which takes the advantage of the superior performance of error control codes, Turbo codes. For comparison, ICIPA algorithm, conventional Turbo coding and IC-TS methods are evaluated and the results are compared. It is observed that more than 3.5 dB additional SNR improvement is achieved in the proposed algorithm compared to traditional Turbo scheme. Hence, it is concluded that IC-TS system will be a compromising approach in 2-D image transmission, recovery of noisy signals and image compression.

REFERENCES

- [1] C. Berrou, A. Glavieux, and P. Thitimajshima, "Near Shannon limit error-correcting coding: Turbo codes," *IEEE International Conference on Communications*, Geneva, Switzerland, May 1993, pp. 1064-1070.
- [2] L. Hanzo, J. P. Woodard, and P. Robertson, "Turbo Decoding and Detection for Wireless Applications," *Proceedings of IEEE*, vol. 95, no. 6, pp. 1178-1200, 2007.
- [3] T. P. O'Rourke, "Robust image communication: an improved design", Ph.D. Dissertation, Dept. Of Electrical Engineering, University of Notre Dame, April 1996.
- [4] O. Osman, O. N. Uçan, and M. Albora, "Iterative Cellular Image Processing Algorithm (ICIPA)", *Istanbul University –Journal of Electrical and Electronics Engineering (IU-JEE)*, vol. 3, no. 1, pp. 775-782, 2003.

- [5] D. Divsalar, and F. Pollara, "Turbo Codes for Deep-Space Communications" *Communications Systems Research Section*, TDA Progress Report 42-120, February 15, 1995.
- [6] K. Buyukatak, E. Gose, O. N. Uçan, S. Kent, and O. Osman, "Channel Equalization and Noise Reduction Based Turbo Codes," *Recent Advances on Space Technology*, Istanbul, Turkey, November 20-22, 2003, pp. 644-648.
- [7] H. Dogan, H. A. Cirpan, and E. Panayirci, "Iterative Channel Estimation and Decoding of Turbo Coded SFBC-OFDM Systems," *Wireless Communications, IEEE Transactions on*, vol.6, no. 8, pp. 3090-3101, 2007.
- [8] R. C. Gonzales, and R. E. Woods, *Digital Image Processing*, ISBN 0-201-50803-6, 1992.
- [9] B. Sklar, "A Primer on Turbo Concepts", *IEEE Communications Magazine*, pp. 94-101, December 1997.
- [10] M. C. Valenti, "Iterative Detection and Decoding for Wireless Communications", A Proposal for Current and Future Work toward Doctor of Philosophy degree, September 1998.
- [11] J. Hagenauer, "Iterative decoding of binary block and convolutional codes," *IEEE Trans. Inform. Theory*, vol. 42, pp. 429-445, Mar. 1996.
- [12] W. J. Gross, and P. G. Gulak, "Simplified MAP Algorithm suitable for implementation of Turbo Decoders," *Electronic Letters*, vol. 34, no. 16, pp. 1577-1578, 1998.