

Effect of Peak-to-Average Power Ratio Reduction on the Multicarrier Communication System Performance Parameters

Sanjay Singh, M Sathish Kumar, and H. S Mruthyunjaya

Abstract—Multicarrier transmission system such as Orthogonal Frequency Division Multiplexing (OFDM) is a promising technique for high bit rate transmission in wireless communication system. OFDM is a spectrally efficient modulation technique that can achieve high speed data transmission over multipath fading channels without the need for powerful equalization techniques. However the price paid for this high spectral efficiency and less intensive equalization is low power efficiency. OFDM signals are very sensitive to non-linear effects due to the high Peak-to-Average Power Ratio (PAPR), which leads to the power inefficiency in the RF section of the transmitter. This paper investigates the effect of PAPR reduction on the performance parameter of multicarrier communication system. Performance parameters considered are power consumption of Power Amplifier (PA) and Digital-to-Analog Converter (DAC), power amplifier efficiency, SNR of DAC and BER performance of the system. From our analysis it is found that irrespective of PAPR reduction technique being employed, the power consumption of PA and DAC reduces and power amplifier efficiency increases due to reduction in PAPR. Moreover, it has been shown that for a given BER performance the requirement of Input-Backoff (IBO) reduces with reduction in PAPR.

Keywords—BER, Crest Factor (CF), Digital-to-Analog Converter (DAC), Input-Backoff (IBO), Orthogonal Frequency Division Multiplexing (OFDM), Peak-to-Average Power Ratio (PAPR), Power Amplifier efficiency, SNR

I. INTRODUCTION

Wireless digital communication is rapidly expanding, resulting in a demand for portable wireless systems that are reliable and have high spectral efficiency. Multicarrier transmission, also known as Orthogonal Frequency Division Multiplexing (OFDM) has been considered as a promising candidate to achieve high rate data transmission in a mobile environment [1], [2]. Due to its robustness against the frequency-selective fading, which produces inter symbol interference (ISI) and degrades the performance [3], OFDM technique has been adopted in some wireless standards such as Digital Audio Broadcasting (DAB), Terrestrial Digital Video Broadcasting (DVB-T), the ETSI HIPER LAN/2 standard, IEEE 802.11a/g/n standard for WLAN and the IEEE 802.16 standard for WiMax [4].

One of the major drawback of OFDM is that its signal has high Peak-to-Average Power Ratio (PAPR) compared to a

single carrier signal because an OFDM signal is the sum of many narrowband signals in the time domain [5]. If the peak transmit power is limited either by regulatory or application constraints, the effect is to reduce the average power allowed under multicarrier transmission relative to that under constant power modulation techniques [6]. This in turn reduces the range of multicarrier transmission. Moreover, to avoid the performance degradation of OFDM signal due to high PAPR, the power amplifier (PA) must be operated in linear region (with large Input-Backoff (IBO)), where the power conversion is inefficient. This may have deleterious effect on battery life time in portable mobile devices, where the drawback of high PAPR may outweigh all the potential benefits of OFDM.

A number of techniques have been proposed to deal with high PAPR problem. These techniques can be broadly classified into four categories :

- 1) Clipping [7]- [9]
- 2) Coding [10]- [13]
- 3) Constellation extension [5], [14]
- 4) Multiple signal representation such as SLM [15] and PTS [16]

There are many work available in the literature such as [17]- [21] which addresses the impact of non-linearities on the performance of a communication system or the OFDM system. Chris et al has discussed the impact of non-linear distortion on the OFDM bit error rate and symbol error rate in [22] and [23] respectively. However, to the best of our knowledge, we could not find such contributions that address the impact of PAPR reduction on the performance of a multicarrier communication system. This is the basic motivation of our work which analytically investigates the impact of PAPR reduction on different aspects of wireless multicarrier transmission system.

The major component of multicarrier communication system which is affected by PAPR is Power Amplifier (PA) and the Digital-to-Analog Converter (DAC) [24]. Therefore, in this paper we have considered the following parameters to study the effect of PAPR reduction:

- Power consumption of PA
- Power amplifier efficiency
- Power consumption of DAC
- Relation between BER and IBO

This paper analytically investigates the effect of PAPR reduction on the performance of a multicarrier communication system irrespective of the PAPR reduction technique applied. It tries to answer the following question due to PAPR reduction:

- 1) what is the saving in power consumption by power amplifier?
- 2) what is the improvement in PA efficiency?
- 3) what is the power saving by DAC?
- 4) what is the effect on IBO to maintain same BER?

The rest of the paper is organized as follows. Section 2 provides the background material for the OFDM signal, PAPR, and distribution of PAR. Section 3 analyzes the impact of PAPR reduction on power amplifier efficiency. Section 4 discusses the power consumption and SNR of DAC when a PAPR reduction technique is employed. Section 5 discusses types of nonlinearities, models and their effect on BER performance. Finally section 6 concludes the paper.

II. PAPR IN OFDM SYSTEM

For the purpose of analyzing the effect of PAPR reduction of OFDM signal, a simplified version of practical OFDM system model has been considered here. Specifically, we ignore the guard interval because it does not contribute to the PAPR [25]. Assuming that any pulse shaping in the transmitter is flat over all of the subcarriers, and deals only with the PAPR of the baseband signal. For one OFDM symbol with N subcarriers, the normalized complex baseband signal can be written as [31] follows:

$$s(t) = \frac{1}{\sqrt{N}} \sum_{k=0}^{N-1} c_k e^{j2\pi kt/T} \quad 0 \leq t \leq T \quad (1)$$

where c_k is the frequency domain information symbol mapped to the k_{th} subcarrier of the OFDM symbol and T is the OFDM symbol duration. The PAPR of the given frequency domain samples, $c = \{c_0, c_1, c_2, \dots, c_{N-1}\}$ is defined as [32] follows:

$$PAPR \triangleq \frac{\max_{0 \leq t \leq T} |s(t)|^2}{E[|s(t)|^2]} \quad (2)$$

where $E[\cdot]$ denotes a time averaging operator. When all the subcarriers are modulated by phase-shift keying (PSK), the theoretical upper bound of the PAPR in OFDM signals with N subcarriers is N . However, as the number of subcarriers increases, the probability of the occurrence of the theoretically highest PAPR becomes negligible [26]. Therefore in order to evaluate PAPR behavior, the statistical distribution of PAPR values should be studied. For this purpose, another parameter called Peak-to-Average Ratio (PAR) or Crest Factor (CF) is used. The PAR is defined as [27] follows:

$$\begin{aligned} PAR &\triangleq \frac{\text{Peak Amplitude}}{\text{RMS Value}} \\ &= \frac{\max |s|}{\sqrt{E[|s|^2]}} \end{aligned} \quad (3)$$

From (2) and (3) it can be inferred that

$$PAR = \sqrt{PAPR}. \quad (4)$$

PAR gives information about the distribution of the signal over the amplitude range. A low PAR value indicates a more uniform distribution, which is advantageous in most cases.

III. EFFECT OF PAPR REDUCTION ON POWER AMPLIFIER EFFICIENCY

Efficiency is a critical factor in PA design. Power amplifier's power consumption is evaluated by drain efficiency, which is defined as [28] the ratio of RF output power to DC input power

$$\eta = \frac{P_{out}}{P_{in}}. \quad (5)$$

Assuming that a PAPR reduction method has been employed. The average DC-input power, P_{inPAPR} , is required to give identical output power, in comparison to the average DC-input power when no PAPR reduction method is used, P_{in} is given by

$$P_{inPAPR} = \xi P_{in} \quad (6)$$

where ξ is a scaling factor, whose value should be less than unity in order to have low value of input DC power for PA after the application of PAPR reduction technique. Considering ζ' as the reduced PAPR value with a PAPR reduction technique applied and ζ as the PAPR value, when no PAPR reduction method is applied. Since $\zeta' < \zeta$, so the value of ξ is given by

$$\xi = \frac{\zeta'}{\zeta}. \quad (7)$$

On substituting for ξ in (6) gives

$$P_{inPAPR} = \frac{\zeta'}{\zeta} P_{in}. \quad (8)$$

The decrease in power consumption (ΔP_c) due to PAPR reduction is obtained as:

$$\Delta P_c = P_{in} - P_{inPAPR}. \quad (9)$$

On substituting for P_{inPAPR} from (8) to (9) yields

$$\begin{aligned} \Delta P_c &= P_{in} - \frac{\zeta'}{\zeta} P_{in} \\ &= \left(\frac{\zeta - \zeta'}{\zeta} \right) P_{in}. \end{aligned} \quad (10)$$

From (10), it is clear that by employing any PAPR reduction technique, the overall reduction in power consumption for the PA is given by a factor of

$$\left(\frac{\zeta - \zeta'}{\zeta} \right). \quad (11)$$

In order to compute power amplifier efficiency due to PAPR reduction (η_{PAPR}), consider (5) and (8), which yields

$$\eta_{PAPR} = \frac{\zeta}{\zeta'} \eta. \quad (12)$$

From (12), it is concluded that the power amplifier efficiency gets scaled up by a factor of $\frac{\zeta}{\zeta'}$ due to PAPR reduction.

Moreover, in order to study the effect of PAPR reduction on power amplifier efficiency, consider an OFDM signal with PAPR equal to 12 dB when no PAPR reduction technique is applied (ζ). Consider PAPR reduction algorithms A1, A2, A3 and A4 with PAPR (ζ') 11, 10, 9 and 8 dB respectively for the same OFDM signal.

From Table 1, it can be observed that there is 8% saving

TABLE I
 SAVING IN POWER CONSUMPTION BY POWER AMPLIFIER DUE TO PAPR
 REDUCTION

PAPR Reduction Algorithm	ζ (dB)	ζ' (dB)	$\Delta P_c = (\frac{\zeta - \zeta'}{\zeta}) P_{in} \times 100$
A1	12	11	8.3%
A2	12	10	16.7%
A3	12	09	25%
A4	12	08	33.3%

in power consumption by power amplifier for every 1 dB reduction in PAPR of the OFDM signal.

TABLE II
 POWER AMPLIFIER EFFICIENCY PERFORMANCE DUE TO PAPR
 REDUCTION ALGORITHMS

PAPR Reduction Algorithm	ζ (dB)	ζ' (dB)	$\eta_{PAPR} = \frac{\zeta}{\zeta'} \eta$
A1	12	11	1.09 η
A2	12	10	1.2 η
A3	12	09	1.33 η
A4	12	08	1.5 η

From Table 2, it can be observed that the efficiency of power amplifier improves by more than 9% with every 1 dB decrease in PAPR of OFDM signal.

IV. EFFECT OF PAPR REDUCTION ON DIGITAL-TO-ANALOG CONVERTER

The digital-to-analog converter (DAC) converts the digital signal obtained at the output of the digital modulation block to analog signal. It is the first block in the analog signal chain of the transmitter. For an ideal n - bit converter, the signal-to-noise ratio (SNR) of the converter for a multicarrier signal is given [27] by

$$SNR = 6.02n + 4.77 - PAR_{dB}. \quad (13)$$

When a PAPR reduction method is employed in the transmitter, the achieved SNR' of the DAC is given by

$$SNR' = 6.02n + 4.77 - PAR'_{dB} \quad (14)$$

where PAR'_{dB} is computed using (4) and is given by

$$PAR'_{dB} = 10 \log \sqrt{\zeta'}. \quad (15)$$

From (13), (14) and (15) it can be easily inferred that

$$SNR' > SNR. \quad (16)$$

Thus for the same resolution of DAC, the SNR performance of the DAC improves due to PAPR reduction.

In order to evaluate how PAPR reduction technique affects the power consumption of a DAC, a particular type of DAC can be simulated. Modern telecommunication applications need high-speed DACs with very low power consumption while providing the required resolution. A current-steering DAC has a very high power efficiency and it is suitable for high-speed and high-resolution applications. The current-steering DAC, uses a number of binary scaled current source elements to generate the output voltage across a load resistor. The power consumption of a DAC is divided into two parts:

- 1) the static power consumption P_s and
- 2) the dynamic power consumption P_d

The dynamic power consumption is due to switching between symbols and therefore has not been considered here. The static power consumption P_s of DAC is given [27] by

$$\begin{aligned} P_s &= V_{dd} I_0 E \left[\sum_{i=0}^{n-1} 2^i b_i \right] \\ &= \frac{1}{2} V_{dd} I_0 (2^n - 1) \end{aligned} \quad (17)$$

where

- V_{dd} is the power supply
- I_0 is the unit current source corresponding to LSB (b_0)
- $E[\cdot]$ is the expectation operator
- n is the resolution of DAC
- b_i is the digital input bit stream

The value of I_0 is constant and depends upon the given hardware technology. From (17) it is observed that the static power consumption of DAC, P_s is a function of DAC resolution only, that is

$$f : P_s \rightarrow (2^n - 1). \quad (18)$$

Having a PAPR reduction technique applied; for a given value of SNR, the new value of DAC resolution, n' is obtained from (14) as:

$$n' = \frac{SNR + PAR'_{dB} - 4.77}{6.02} \quad (19)$$

where the value of PAR'_{dB} is obtained from (15). Thus the power consumption of DAC can be expressed as a function of PAR as

$$P'_s = \frac{1}{2} V_{dd} I_0 \left(2^{\frac{SNR + PAR'_{dB} - 4.77}{6.02}} - 1 \right). \quad (20)$$

The amount of power saving achieved for DAC, by employing PAPR reduction technique is given by

$$\begin{aligned} \frac{\Delta P_s}{P_s} &= \frac{P_s - P'_s}{P_s} \\ &= \frac{2^n - 2^{n'}}{2^n - 1}. \end{aligned} \quad (21)$$

From (13) and (19) it can be observed that due to PAPR reduction

$$n' < n. \quad (22)$$

From (21) and (22), it is inferred that by employing a PAPR reduction technique, the overall reduction in power consumption for the DAC alone is given by a factor of

$$\left(\frac{2^n - 2^{n'}}{2^n - 1} \right). \quad (23)$$

TABLE III
 POWER SAVING BY DAC DUE TO PAPR REDUCTION

PAPR reduction algorithm	ζ (dB)	ζ' (dB)	PAR'_{dB}	n'	$\Delta P_s = \frac{2^n - 2^{n'}}{2^n - 1} P_s \times 100$
A1	12	11	5.5	2.61	6.42%
A2	12	10	5	2.53	12.47%
A3	12	9	4.5	2.45	18.17%
A4	12	8	4	2.36	24.22%

From Table 3, it is inferred that there is 6% saving in power by DAC for every 1 dB reduction in PAPR.

V. TYPES OF NONLINEARITIES, MODELS AND THEIR EFFECT ON BER PERFORMANCE

There are many blocks in a communication system whose intended behavior is linear but the physical devices that are used to implement these functions may produce nonlinear effects over a certain range of operations. One of the example of such a device is a high-power amplifier, which exhibits limiting and saturation when the input amplitude or power is very large. Nonlinearities in communication systems are classified as

- 1) baseband and
- 2) bandpass

For example, a limiter is an example of a baseband nonlinearity whereas a radio frequency (RF) amplifier is a bandpass nonlinearity. The input to a bandpass nonlinearity will be centered at some frequency f_c and the spectral components of the output will lie in the neighborhood of f_c .

A. Baseband Nonlinearities

The input to a baseband nonlinearity is a real-valued signal, $x(t)$ and its output is also a real-valued signal, $y(t)$. The nonlinearity is modeled as $y(t) = F(x(t))$. The most commonly used models of baseband nonlinearities are the power series model and the limiter model. The power series model is defined as [29] follows:

$$y(t) = \sum_{k=0}^N a_k x^k(t) \quad (24)$$

and the general limiter model has the form

$$y(t) = \frac{M \operatorname{sgn}(x(t))}{[1 + (\frac{m}{|x(t)|})^s]^s} \quad (25)$$

where M is the limiting value of the output, m is the limiting value of input and s is the shape parameter. Fig.1 shows the normalized input-output relationship for a limiter as defined by (25) for different values of s . It is noted that in Fig.1, $s = \infty$ corresponds to a soft limiter and $m = 0$ corresponds to a hard limiter. Moreover, it is noted that with $m = 0$, the value of s has no effect on the characteristic of the nonlinearity as described by (25).

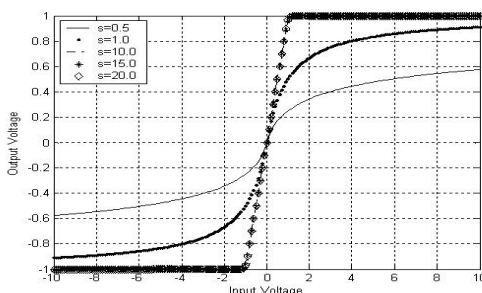

Fig. 1. Limiter Characteristic

B. Bandpass Nonlinearities

Memoryless bandpass models are used to characterize a variety of narrowband nonlinear bandpass devices encountered in communication systems. The word memoryless implies not only an instantaneous relationship between input and output, but also implies that the device does not exhibit frequency-selective behavior over the bandwidth of operation. The bandwidth of the nonlinear device and the bandwidth of the signal are both assumed to be much less than f_c , where f_c is the carrier frequency. Consider a cubic memoryless nonlinearity of the form

$$y(t) = x(t) - \alpha x^3(t) \quad \alpha < 1 \quad (26)$$

where α is the scaling factor for the cubic component. Assuming that the input is a random signal in the form of

$$x(t) = A(t) \cos[2\pi f_c t + \phi(t)] \quad (27)$$

where the amplitude $A(t)$ and the phase $\phi(t)$ are lowpass random processes having bandwidth $B \ll f_c$. From (26) and (27), output of the nonlinearity is given by

$$y(t) = [A(t) - \frac{3\alpha}{4} A^3(t)] \cos[2\pi f_c t + \phi(t)] - \frac{\alpha}{4} A^3(t) \cos[6\pi f_c t + 3\phi(t)]. \quad (28)$$

In (28), the first term is at the center frequency f_c and the second term is at the third harmonic of the carrier frequency $3f_c$. The bandwidth of the third harmonic will be of the order of $3B$. Since the assumption is that $f_c \gg B$, the second term is outside the bandwidth of interest. Thus the approximated output of the nonlinearity is given by

$$z(t) \approx [A(t) - \frac{3\alpha}{4} A^3(t)] \cos[2\pi f_c t + \phi(t)] \approx f(A(t)) \cos[2\pi f_c t + \phi(t)] \quad (29)$$

where $f(A(t)) = [A(t) - \frac{3\alpha}{4} A^3(t)]$. For the power series model, the bandpass output $y(t)$ has the same form as that of the input with the output amplitude related to the input amplitude via $f(A(t))$ and the output phase is the same as the input phase. The function $f(A(t))$ is referred to as the input amplitude to output amplitude, or the AM-to-AM transfer characteristic of the nonlinearity. A limiter or power series model affects only the amplitude of the input signal. The phase is unaffected by the model. In terms of the complex envelopes of the input $x(t)$ and the output $z(t)$, the lowpass equivalent model for the power series nonlinearity is given by

$$\tilde{x}(t) = A(t) \exp[j\phi(t)] \quad (30)$$

and

$$\tilde{z}(t) = f[A(t)] \exp[j\phi(t)]. \quad (31)$$

C. AM-to-AM and AM-to-PM Models

Devices such as bandpass amplifiers, having spectra centered on the carrier frequency, produce outputs that are bandpass in nature. The spectral components of these bandpass outputs are centered on the carrier frequency but have larger bandwidths than the input signal. Such devices can be modeled

using the complex envelope representations of the input and output signals. Suppose the input to a memoryless bandpass nonlinearity is of the form

$$x(t) = A(t) \cos[2\pi f_c t + \phi(t)] = A \cos(\theta) \quad (32)$$

where $\theta = 2\pi f_c t + \phi(t)$. The output of the memoryless nonlinearity $y(t) = F(x(t))$ can be expressed as

$$y(t) = F(A \cos(\theta)). \quad (33)$$

As $A \cos(\theta)$ is periodic in θ , $y(t)$ is also periodic in θ and therefore can be expanded using Fourier series [33] as

$$y(t) = a_0 + \sum_{k=0}^{\infty} (a_k \cos(k\theta) + b_k \sin(k\theta)) \quad (34)$$

where a_k and b_k are the Fourier coefficients and are given by

$$a_k = \frac{1}{\pi} \int_0^{2\pi} F(A \cos(\theta)) \cos(k\theta) d\theta \quad (35)$$

and

$$b_k = \frac{1}{\pi} \int_0^{2\pi} F(A \cos(\theta)) \sin(k\theta) d\theta. \quad (36)$$

The first zone output $z(t)$ in the vicinity of f_c is given by the $k = 1$ term in the Fourier series. Hence

$$z(t) = f_1(A(t)) \cos[2\pi f_c t + \phi(t)] + f_2(A(t)) \sin[2\pi f_c t + \phi(t)] \quad (37)$$

where

$$f_1(A) = a_1 = \frac{1}{\pi} \int_0^{2\pi} F(A \cos(\theta)) \cos(\theta) d\theta \quad (38)$$

and

$$f_2(A) = b_1 = \frac{1}{\pi} \int_0^{2\pi} F(A \cos(\theta)) \sin(\theta) d\theta. \quad (39)$$

The model given by (37) can also be written as

$$z(t) = f(A(t)) \cos[2\pi f_c t + \phi(t) + g(A(t))] \quad (40)$$

where

$$f(A(t)) = \sqrt{f_1^2(A) + f_2^2(A)} \quad (41)$$

and

$$g(A(t)) = \arctan \frac{f_2(t)}{f_1(t)}. \quad (42)$$

In polar coordinates

$$f(A) \exp(jg(A)) = f_1(A) + j f_2(A). \quad (43)$$

The function $f(A)$ and $g(A)$ are the amplitude-to-amplitude (AM-to-AM) and amplitude-to-phase (AM-to-PM) transfer characteristics. The model given by (40) accounts for both the amplitude distortion and phase distortion introduced by the nonlinearity, and it can be expressed in terms of the complex lowpass equivalents of the input and output as

$$\tilde{x}(t) = A(t) \exp[j\phi(t)] \quad (44)$$

and

$$\tilde{z}(t) = f(A(t)) \exp(jg(A(t))) \exp(j\phi(t)). \quad (45)$$

Equation (45) can be used to model a Traveling Wave Tube

power amplifier (TWT).

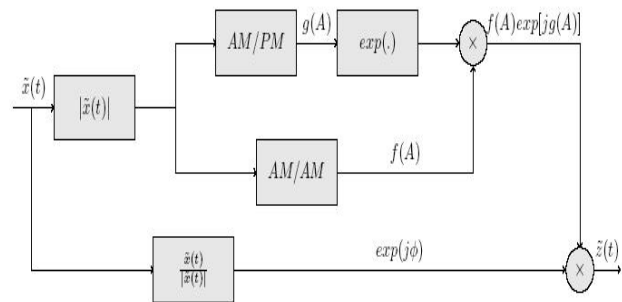

Fig. 2. Model of TWT

The block-diagram representation of (45) is shown in Fig.2. For our simulation, we have used Saleh's model [30] to obtain AM-to-AM and AM-to-PM characteristics. The functional form of the Saleh's model is given by

$$f(A) = \frac{\alpha_f A}{1 + \beta_f A^2} \quad (46)$$

and

$$g(A) = \frac{\alpha_g A^2}{1 + \beta_g A^2} \quad (47)$$

where $\alpha_f = 1.1587$, $\beta_f = 1.15$, $\alpha_g = 4.0$ and $\beta_g = 2.1$. A PA operates efficiently when the power of the input signal is constant and almost equal to the saturation point of the amplifier. In such a case the power amplifier operates in the linear region and achieves the maximum amplification of the input signal. But in case of multicarrier transmission system, the power of the input signal is not constant as a result of which amplifier consumes more power, making the power amplifier very inefficient. The operating point of an amplifier is given by the back-off. High back-offs move the operating point of the amplifier to the linear region, which reduces the effects of nonlinearities. The input back-off (IBO) of a power amplifier is defined [34] as follows:

$$IBO = 10 \log_{10} \left(\frac{A_{sat}^2}{E[|s(t)|^2]} \right) \quad (48)$$

where $E[|s(t)|^2]$ denotes the mean power of the input signal $s(t)$ and A_{sat} denotes the amplifier input saturation voltage. When PA enters the saturation region the output power does not increase as the input power is increased. So when the power amplifier operates using an IBO, which assures that there is no transition to the saturation region.

To observe the effect of nonlinearity of PA, consider a 16-QAM modulated OFDM signal model, which can be rewritten from (1) here as

$$x(t) = \frac{1}{\sqrt{N}} \sum_{k=0}^{N-1} c_k e^{j \frac{2\pi k t}{T}} \quad 0 \leq t \leq T \quad (49)$$

where $c_k = a_k + j b_k$, a and b are the inphase and quadrature phase components of 16-QAM signal constellation and is given by:

$$(a, b) = \begin{bmatrix} (-3, 3) & (-1, 3) & (1, 3) & (3, 3) \\ (-3, 1) & (-1, 1) & (1, 1) & (3, 1) \\ (-3, -1) & (-1, -1) & (1, -1) & (3, -1) \\ (-3, -3) & (-1, -3) & (1, -3) & (3, -3) \end{bmatrix}$$

Let $\Gamma = |x|$, represent the magnitude of $x(t)$. In (46) and (47), $A = \Gamma * IBO$, where IBO is defined by (48). Now rewriting (46) and (47) in terms of Γ and IBO as

$$f_{AM-AM}(\Gamma, IBO) = \frac{\alpha_f \Gamma (IBO)}{1 + \beta_f \Gamma^2 (IBO)^2} \quad (50)$$

and

$$g_{AM-PM}(\Gamma, IBO) = \frac{\alpha_g \Gamma^2 (IBO)^2}{1 + \beta_f \Gamma^2 (IBO)^2} \quad (51)$$

When the 16-QAM lowpass signal (49) is passed through the nonlinear amplifier given by (45) and modeled using Saleh's model (50) and (51), the resulting signal is given by

$$\tilde{z}(t) = \left(\frac{\alpha_f \Gamma (IBO)}{1 + \beta_f \Gamma^2 (IBO)^2} \right) \exp\left(j \frac{\alpha_g \Gamma^2 (IBO)^2}{1 + \beta_f \Gamma^2 (IBO)^2}\right) \exp(j\phi) \quad (52)$$

where $\exp(j\phi) = \frac{x}{|x|}$. Input and output constellation plot for different values of IBO are obtained from (49) and (52).

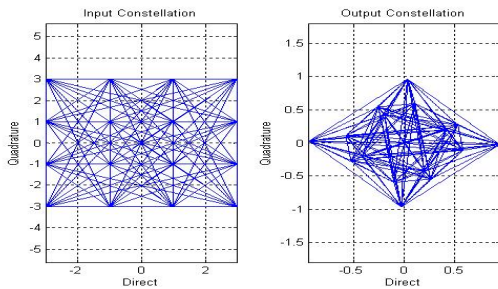

Fig. 3. Input and Output Constellation for 1dB backoff

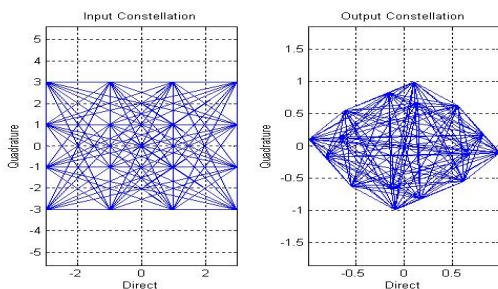

Fig. 4. Input and Output Constellation for 5dB backoff

From Figs.3-7, it can be observed that the effect of non-linearity of PA is to move number of signal constellation points close together. For AWGN channel it is known that, the pairwise error probability is a monotonic function of the Euclidean distance between a pair of points in the signal space. Error probability increases as the signal space move close together. Therefore, it can be concluded that the nonlinearity of the power amplifier degrades the BER performance of the communication system. Moreover, from Figs.4-7, it

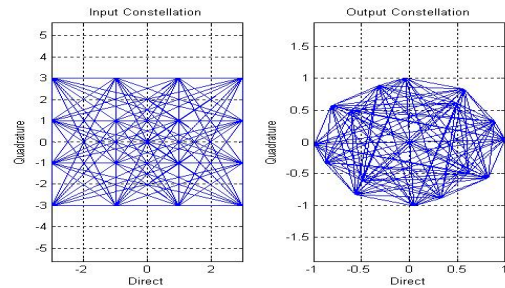

Fig. 5. Input and Output Constellation for 10dB backoff

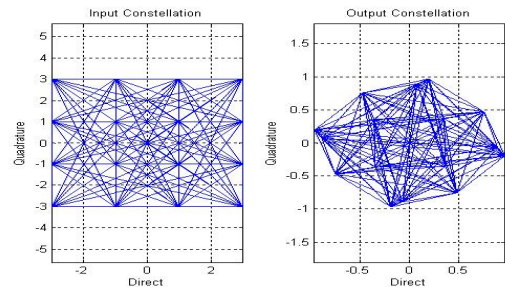

Fig. 6. Input and Output Constellation for 15dB backoff

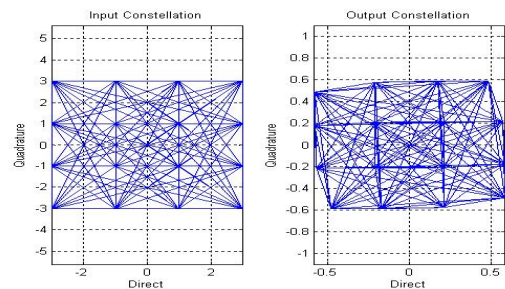

Fig. 7. Input and Output Constellation for 20dB backoff

is observed that when PA operates with IBO, the severity of amplitude degradation reduces with increasing IBO. But operating PA with large value of IBO is not power efficient. This affects the system BER performance.

When PAPR reduction technique is employed, the requirement of IBO reduces for a given BER performance, it leads to the power saving without compromising the BER performance of the system.

VI. CONCLUSION

OFDM is a promising technique for high-speed wireless communication systems. A major drawback of conventional OFDM system is the high peak-to-average power ratio. In this paper, the effect of PAPR reduction on various aspects of multicarrier communication systems parameters irrespective of the PAPR reduction technique applied have been analyzed. Performance parameters considered are the power consumption of PA and DAC, power amplifier efficiency, SNR of DAC, and the BER performance.

From this analysis it is found that ,the overall reduction in power consumption by PA is 8% for every 1 dB reduction in

PAPR. There is more than 9% improvement in the PA efficiency for every 1 dB reduction in PAPR. For DAC the reduction in power consumption is more than 6% for every 1 dB reduction in PAPR.

For the same resolution of DAC, the SNR performance of DAC improves due to reduction in PAPR. Moreover, it has been shown that the effect of nonlinearity of PA is to move the number of signal constellation points close together. As a result of which the systems BER performance degrades. The severity of BER performance degradation reduces when the PA is operated with increasing IBO. When PAPR reduction technique is employed, the requirement of IBO reduces for a given BER performance which leads to the power saving without compromising the BER performance of the system.

However actual effect of PAPR reduction on these performance parameters depends on the individual PAPR reduction techniques.

REFERENCES

- [1] M.R Nakhai, Multicarrier Transmission, "IET Signal Process.", vol.2, no.1, pp.1-14, (2008).
- [2] Xiaodong Zhu, Tao Jiang and Guangxi Zhu, Novel Schemes Based on Greedy Algorithm for PAPR Reduction in OFDM Systems, *IEEE Trans. Consum. Electro.*, vol.54, no.3, pp.1048-1052, (2008).
- [3] Haris Gacanan and Fumiuyuki Adachi, A Comprehensive Performance Comparison of OFDM/TDM Using MMSE-FDE and Conventional OFDM, *Proc.VTC 2008*, pp.1404-1408, (2008).
- [4] Jeffrey G.Andrews, Arunabha Ghosh and Rias Muhamed, *Fundamentals of WiMAX: Understanding Broadband Wireless Networking*, Prentice Hall, Upper Saddle River, NJ, (2007).
- [5] Seung Hee Han, John M.Cioffi and Jae Hong Lee, On the Use of Hexagonal Constellation for Peak-to-Average Power Ratio of an OFDM Signal, *IEEE Trans. Wireless Commun.*, vol.7, no.3, pp.781-786, (2008).
- [6] Seung Hee Han and Jae Hong Lee, An Overview of Peak-to-Average Power Ratio Reductions for Multicarrier Transmission, *IEEE Wireless Commun. Mag.*, vol.12, no.2, pp.56-65, (2005).
- [7] R.O'Neill and L.B Lopes, Envelope Variations and Spectral Splatter in Clipped Multicarrier Signals, *Proc.IEEE PIMRC'95*, Toronto, Canada, pp.71-75, (1995).
- [8] X. Li and L.J Cimini, Jr. ,Effects of clipping and filtering on the performance of OFDM, in *IEEE 47th VTC*, pp.1634-1638, (1997).
- [9] J.Armstrong, Peak-to-Average Power Reduction for OFDM by Repeated Clipping and Frequency Domain Filtering, *Elect.Lett.*, vol.38, no.8, pp.246-47, (2002).
- [10] A.E Jones, T.A Wilkinson and S.K Barton, Block Coding Scheme for Reduction of Peak-to-Mean Envelope Power Ratio of Multicarrier Transmission Scheme, *Elect.Lett.*, vol.30, no.22, pp.2098-2099, (1994).
- [11] V.Tarokh and H.Jafarkhani, On the Computation and Reduction of the Peak-to-Average Power Ratio in Multicarrier Communications, *IEEE Trans.Commun.*, vol.48, no.1, pp.37-44, (2000).
- [12] J.A Davis and J.Jedwab, Peak-to-Mean Power Control and Error Correction for OFDM Transmission using Golay Complementary Sequences and Reed-Muller Codes, *IEEE Trans.Inf.Theory*, vol.45, no.7, pp.2397-2413, (1999).
- [13] Robert F.H Fischer and Christian Siegel, Reed-Solomon and Simplex Codes for Peak-to-Average Power Ratio Reduction in OFDM, *IEEE Trans. Info.Theory*, vol.55, no.4, pp.1519-1528, (2009).
- [14] B.S Krongold and D.L Jones, PAR Reduction in OFDM via Active Constellation Extension, *IEEE Trans.Broadcast.*, vol.49, no.3, pp.258-268, (2003).
- [15] R.W Bauml, R.F.H Fisher and J.B Huber, Reducing the Peak-to-Average Power Ratio of Multicarrier Modulation by Selected Mapping, *Elect.Lett.*, vol.32, no.22, pp.2056-2057, Oct.1996.
- [16] S.H Muller and J.B Huber, OFDM with Reduced Peak-to-Average Power Ratio by Optimum Combination of Partial Transmit Sequences, *Elect.Lett.*, vol.33, no.5, pp.368-369, Feb.1997.
- [17] Silvano Pupolin and Larry J.Greenstein, Performance Analysis of Digital Radio Links with Nonlinear Transmit Amplifiers, *IEEE Jol.SAC.*, vol.5, no.3, pp.534-546, (1987).
- [18] A.Ghorbani and M.Sheikhan, The Effect of Solid State Power Amplifiers (SSPAs) Nonlinearities on MPSK and M-QAM Signal Transmission, in *procce. 6th Intl. Conf.on Digital Processing of Signals in Commun.*, pp.193-197, (1991).
- [19] Qun Shi, OFDM in Bandpass Nonlinearity, *IEEE Tran. Consum.Elec.*, vol.42, no.3, pp.253-258, (1996).
- [20] D.Dardari, V.Tralli and A.Vaccari, Analytical Evaluation of Total Degradation in OFDM systems with TWTA or SSPA, tech.rep., University of Bologna DEIS, in CSITE-CNR, (1999).
- [21] Sergey V.Zhidkov, Performance Analysis of Multicarrier Systems in the Presence of Smooth Nonlinearity, *EURASIP Journal on Wireless Communications and Networking*, vol.2, pp.335-343, (2004).
- [22] Chris.van den Bos, Michiel H.L.Kouwenhoven and Wouter A.Serdijn, The Influence of Non-linear Distortion on OFDM Bit Error Rate, in *Proc.ICC 2000*, vol.2, pp.18-22, (2000).
- [23] Chris.van den Bos, Michiel H.L.Kouwenhoven and Wouter A.Serdijn, Effect of Smooth Nonlinear Distortion on OFDM Symbol Error Rate, *IEEE Tran., Commun.*, vol.49, no.9, pp.1510-1514, (2001).
- [24] Y.Li, B.Bakkaloglu and C.Chakrabarti, A Comprehensive Energy Model and Energy-Quality Evaluation of Wireless Transceiver Front-Ends, *Proc.SIPS*, pp.262-267, (2005).
- [25] Jose Tellado, *Multicarrier Modulation with Low PAR: Applications to DSL and Wireless*, Kluwer Academic Publisher, Boston, (2000).
- [26] H.Ochai and H.Imai, On the Distribution of the Peak-to-Average Power Ratio in OFDM Signals, *IEEE Trans. Commun.*, vol.49, no.2, pp.282-289, (2001).
- [27] M.Gustavsson, J.Wikner and N.N.Tan, *CMOS Data Converters for Communications*, Kluwer Academic Publisher, New York, 2002.
- [28] Frederick H.Raab, Peter Asbeck, Steve Cripps, Peter B.Kenington, Zoya B.Popovic, Nick Potheary, John F.Sevic and Nathan O.Sokal, Power amplifier and transmitters for RF and microwave, *IEEE Trans.Microw.Theory Tech.*, vol.50, no.3, pp.814-826, (2002).
- [29] M.C. Jeruchim, P.Balaban and K.S Shanmugan, *Simulation of Communication Systems*, 2nd ed., New York, Kluwer Academic Publishers, (2000).
- [30] A.A.M Saleh, Frequency-independent and frequency-dependent nonlinear models of TWT amplifiers, *IEEE Trans.Commun.*, vol.29, no.11, pp.1715-1720, (1981).
- [31] Richard Van Nee and Ramjee Prasad, *OFDM for Wireless Multimedia Communication*, Boston, Artech House, (2000).
- [32] Andrea Goldsmith, *Wireless Communications*, Cambridge University Press, (2005).
- [33] John G.Proakis and Masoud Salehi, *Communication Systems Engineering*, 2nd Ed., Pearson Education, New Delhi, (2005).
- [34] Ismail Shakeel and Alex Grant, Joint Error Correction and PAPR Reduction of OFDM Signals, in *Proc.2006 IEEE Information Theory Workshop., ITW'06*, pp.611-615, (2006).



Sanjay Singh graduated from the Institution of Electronics and Telecommunication Engineers (IETE), Delhi in 2001 and received M.Tech in Electronics and Communication Engineering from Manipal Institute of Technology, Manipal in 2003. Currently he is pursuing Ph.D in the Department of Information and Communication Technology at MIT Manipal. His current research interest includes multicarrier modulation systems, spread-spectrum communication, signal processing for communication and their application to wireless communication.



M.Sathish Kumar graduated in E&C Engineering from the Institution of Engineers (India) in the year 1991 and received M.Tech degree in E&C Engineering from College of Engineering, Anna University, Chennai in the year 1998 and PhD in E&C Engineering from National Institute of Technology, Karnataka, India in the year 2004. He was with the Optical Communication System Lab of School of Electrical Engineering, Seoul National University from September 2006 to August 2007 as an International Scholar Exchange Fellow of the Korea

Foundation for Advanced Studies. His areas of research interests include optical CDMA, multilevel modulation schemes for optical communications and nanophotonic devices for optical communications. He has authored or coauthored over 40 publications in journals/conference proceedings. Currently he is a Professor at the Department of Electronics and Communication Engineering, Manipal Institute of Technology, Manipal, India.



H.S.Mruthyunjaya graduated in Electronics and Communication Engineering from Mysore University in 1988 and obtained his masters degree in Electronics and Control Systems Engineering from Birla Institute of Technology and Science (BITS), Pilani in 1994. He has a Ph.D in Electronics and Communication Engineering conferred by Manipal University for his thesis entitled 'Performance Enhancement of Optical Communication Systems and Networks using Error Control Techniques'. He is currently serving as a Professor in the Department of

Electronics and Communication Engineering, Manipal Institute of Technology, Manipal, India where he joined as a Lecturer in the year 1998. He has done research on countering non-linear effects and other noises in WDM all-optical networks by employing error control coding techniques. His areas of major interests are the Optical Fiber Communication systems, Fiber Optics, Photonic Crystal Fibers, WDM networks and systems, Electromagnetic theory and General areas of Digital Communication Systems. He has authored or co-authored over 12 technical papers in refereed journals and Ten International conference proceedings. He is a Fellow of the Institution of Engineers (India) and member of Indian Society for Technical Education.