

MIMO-OFDM Coded for Digital Terrestrial Television Broadcasting Systems

El Miloud A.R. Reyouchi, Kamal Ghoumid, Koutaiba Amezian, and Otman Mrabet

Abstract—This paper proposes and analyses the wireless telecommunication system with multiple antennas to the emission and reception MIMO (multiple input multiple output) with space diversity in a OFDM context. In particular it analyses the performance of a DTT (Digital Terrestrial Television) broadcasting system that includes MIMO-OFDM techniques. Different propagation channel models and configurations are considered for each diversity scheme. This study has been carried out in the context of development of the next generation DVB-T/H and WRAN.

Keywords—MIMO, MISO, OFDM, DVB-H/T2, WRAN.

I. INTRODUCTION

THE multi-antenna systems in the broadcast (emission) and in the reception (Multi-input Multi-output MIMO) is a key technique For the wireless cellular communications of the generation (wireless RAN., as well as the broadcasting (DVB)) [1] allow in theory to increase the capacity of the links of wireless communications with regard to the systems consisted of a single antenna in the emission and in the reception (Single input Single output SISO). By making the hypothesis where the routes between every antenna emission and reception are independent. Foshini [2] and Telatar [3] demonstrated that the theoretical capacity of the channel MIMO with N_t antennas in the emission and the N_r antennas in the reception believes linearly with $\min(N_t, N_r)$. The MIMO systems are one of the main axes of development to increase the bit rate of data transmission of the wireless communications.

The MIMO systems present two major advantages with regard to the systems SISO:

- 1- Thanks to the contribution of the spatial diversity they allow to improve the quality of the link by franking from faints, fading of channels.
- 2- By spatial multiplexing, they allow to increase the bit rate of information without increasing the bandwidth or the power transmitted.

Since DVB-T system was designed, modulation techniques and error coding methods have suffered an important development [4]. Moreover, it is now possible to add much more sophisticated technology in receivers maintaining costs.

E. Arreyouchi, K. Amezian, and O. Mrabet are with the Department of physique, faculty of Science, Abdelmalek Essaadi university, Tetouan, Morocco, (e-mail: arreyouchi@hotmail.com, ktbamezian@gmail.com, o.mrabet@gmail.com).

K. Ghoumid is with the Department of Electronics, Informatics and Telecommunications, National School of Applied Sciences, Mohammed Premier university, Complexe Al Qods, B.P. 669, 60000 Oujda, Morocco, (email: kghoumid@ensa.univ-oujda.ac.ma).

These facts together with a larger capacity requirement for HDTV (High Definition Television) have led to the necessity of the next generation DVB-T called DVB-T2 [5].

The inclusion of MIMO techniques in DVB-T2 seems to be a fact. At the moment, in the first draft specification of DVB-T2 [5] MISO techniques are considered, which could be the beginning for a complete diversity support by a further inclusion of MIMO techniques.

In OFDM systems the most used techniques to include MIMO support are the space-time and space-frequency coding techniques [6]. The proposed codification technique for MISO in the DVB-T2 draft [5] is based on the Alamouti's code [7]. The proposed method is a space-frequency code, derived from a modified coding matrix of the original Alamouti space-time code.

In order to use MISO techniques it is necessary to increase the number of transmit antennas and modify the transmission and reception equipment. Additionally, in the case of MIMO, it is also necessary to add antennas to the receivers. All this means an important investment in infrastructure. So, a study must be carried to see if the improvement in the system performance justifies it.

In the following of this paper we are interested in MIMO – OFDM system of the next generation DVB-T/H for the proposed system (Fig. 2) but may also be applicable for the future standard WRAN which operates also in TV bands [8] wherein MIMO-OFDM: will improve performance of BER as well as reduce feedback information and Improve spectral efficiency of CR system.

II. OBJECTIVES

The main objective is to compare the reception quality in the most current configuration of antenna system SISO, MISO and MIMO SISO DVB-T broadcasting scheme (Fig. 1), this is the most currently used method, without encoder MIMO, in all countries of the worlds, with the new proposed MISO and MIMO diversity schemes (Fig. 2).

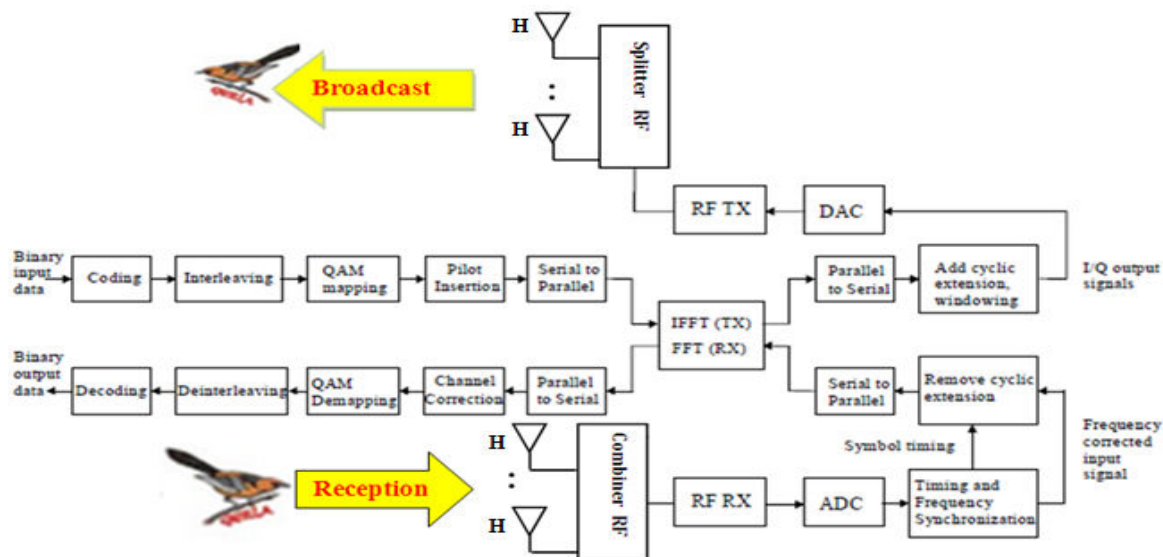

Fig. 1 Simulated MIMO system: Block diagram of an OFDM Transceiver: The figure summarizes the various operations made on the binary flow (for example, stemming from a MPEG encoder). It is yet the synoptic plan of a TV broadcasting station (Digital Terrestrial Television DTT) or other equipment of transmission there using the principle OFDM or COFDM principle

As one of the proposed modified Alamouti's code characteristic is the fact that it allows backward compatibility when using polarization diversity, this ability has to be proven.

It is also important to study if the proposed modification to the Alamouti's code for the MIMO configuration affects the system efficiency, comparing it to the one of the original Alamouti's coding matrix.

No multi-antenna technology is implemented in the DVB-T standard. In contrast, a distributed STBC scheme and based on Alamouti code is optional in the standard DVB-T2 [9].

III. SYSTEM

A. System Proposed

A simulator of the new system proposed has been developed in Matlab to carry out all the studies. This simulator includes a transmission and reception DVB-T chain, to which MIMO coding and decoding blocks are added (Fig. 2).

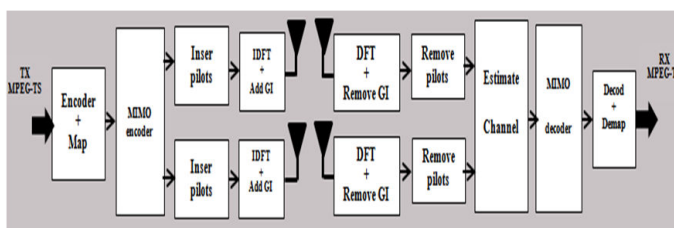

Fig. 2 MIMO system proposed with (encoder MIMO) for generation DVB-T2

At the transmitter side, after the coding and modulation process – including: MUX adaptation & energy dispersal, outer coder, outer interleaver, inner coder, inner interleaver and mapping data in the constellation – the MIMO coding process are performed. The outputs of this process are handled as two independent fluxes to which pilot insertion; frequency

to time translation and guard interval insertion must be applied. The receiver consists of the complementary blocks, so it recovers the transmitted information.

B. Coding

In Alamouti's space-time code [7] each row represents the transmitting antenna and each column represents a time interval.

Taking this code as the base and moving the time technique to the frequency domain, the frequency-time code results into the one in (1) see Fig. 3.

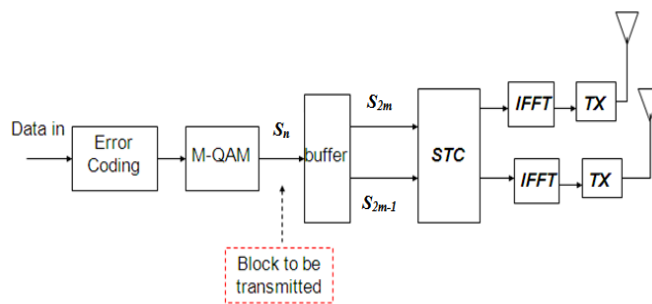

Fig. 3 Down Link: Transmit Diversity use Alamouti Space Time Coding

$$\bar{C} = \begin{bmatrix} S_{(2m-1)} & -S_{(2m)}^* \\ S_{(2m)} & S_{(2m-1)}^* \end{bmatrix} \quad (1)$$

where $S_{(2m)}$ represents the conjugation of $S_{(2m)}^*$.

Each row represents, as before, the transmitting antenna but now the column represents the data carrier. Thus from the first antenna, in the first carrier the first data carrier of the OFDM symbol is transmitted. In the second one the carrier of the symbol in the same position but conjugated and inverted is

transmitted. From the second antenna, in the first carrier the second data carrier is sent. In the second carrier the first data carrier in OFDM symbol conjugated is transmitted. This code is applied to every pair of data carrier in each OFDM symbol.

The modified code proposed to allow backward compatibility, is the transposed matrix of (2).

$$\bar{C} = \begin{bmatrix} S_{(2m-1)} & -S_{(2m)} \\ -S_{(2m)}^* & S_{(2m-1)}^* \end{bmatrix} \quad (2)$$

The first row represents the data carriers transmitted by the first antenna. Data carriers transmitted from this antenna maintain the position and value of the original OFDM symbol.

This means that from the first antenna, the same signal as the one that would be broadcast in a SISO scheme is transmitted, which eases backward compatibility.

By using orthogonal polarization in the transmitter antennas, both transmissions can be received separately. The first antenna will be horizontally polarized, as it is the case of current DVB-T receivers, and the second antenna will have vertical polarization. Hence current receivers will receive mainly the data transmitted by the first antenna. On the other hand, new receivers including MIMO decoding will be provided of two antennas, one with horizontal polarization and the other one with vertical polarization, so they can receive information from both paths, benefiting from spatial diversity.

It must not be ignored that a small amount of signal level can be received by the antenna with the opposite polarization. This will also be considered in the simulations (Fig. 4).

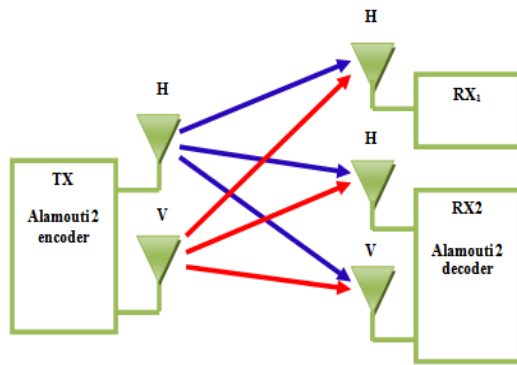

Fig. 4 Broadcasting scheme when coexisting MIMO and SISO receivers

In order to simulate this effect, a cross-polar factor (XPD) has been defined to attenuate h_{ij} $i \neq j$, paths. The minimum and maximum values are 9 dB and 25 dB respectively.

In [5] it is proposed an optional MISO inclusion in DTT broadcasts with the codification shown in (3). There is no mention to the use of polarization diversity, so that solution would create the necessity of using new frequencies.

C. Channels

To obtain useful results, it is a crucial point to simulate suitable propagation channels. For that reason Rayleigh channel F1 have been selected as the propagation channels.

Channels in MIMO form a matrix (3),

$$\bar{H} = \begin{bmatrix} H_{11} & H_{12} \\ H_{21} & H_{22} \end{bmatrix} \quad (3)$$

This shows all the possibilities of paths between each transmitter and receiver antenna. In MISO the matrix reduces to the array (4):

$$\bar{H} = [H_{11} \ H_{12}] \quad (4)$$

where H_{ij} represents the path between the 'i' receiver and the 'j' transmitter.

IV. PRACTICE AND RESULTS

In this work, MATLAB is used to test the channel performance using diversity technique based on 64QAM modulation scheme. By applying Alamouti's diversity and/or technique and measurements are performed in the Rayleigh channel.

The selected values for modulation and coding parameters in all the simulations are the ones used for Moroccan DVB-T transmissions. These values are the following ones.

- Channel Width: 8.00 MHZ.
- Measurement filter: 230KHZ
- Transmission mode: 8K
- Non-hierarchical mapping.
- Constellation: 64-QAM.
- Code rate: 3/4.
- Guard interval: 1/16.

The QEF (Quasi Error Free) reception quality criteria have been used to analyze the reception quality. It corresponds to a BER of 10^{-11} after Reed-Solomon decoder and a BER of 2×10^{-4} after soft Viterbi decoder. BER after Viterbi decoder is the parameter that will be analyzed.

A. Equipment and Method

This paper deals with a Matlab application currently being developed to simulate DVB-T transmission in various transmission channels. The application structure and its functions are described. The aim was to implement all the functional blocks as specified in the DVB-T specification. Dependence of BER on C/N ratio as a result of the simulation in the Rayleigh channel is graphically expressed and compared to the results of the laboratory measurement. The reference measurement was performed using transmitter NEC, EGATEL unit as the transmitter and Promax PROLINK-4/4C (Level meter) test receiver. Finally, obtained results are discussed compared to the results of the laboratory measurement.

1. Equipment Used

Broadcasting side

- Two transmitters DVB brand NEC UHF channel 24 (498 MHz) power from 0 to Watts 1000Watts.

- A transmitter DVB brand EGATEL UHF Channel: 32 (562 MHz) power from 0 to Watts 1000Watts.
- Three panel antennas of horizontal polarization.
- Four antennas/Power Distribution System, 470- 952 MHz UHF (a input- a output) (input-two output) (input-three outputs) (two input-two outputs)

Receiving case

- Level meter PROLINK-4/4C Premium-PROMAX, taking in our case using the following parameters:
- Antennas (AMC / 1) UHF (470 MHz to 860 MHz) at a height of 2m from the ground.
- Three power couplers (Two inputs - one output), (Two inputs - Two output) while the other has three inputs and a one output.

In this practical work we have taken the following steps:

- C / N: carrier-to-noise ratio.
- BER after Viterbi VBER (Bit Error Rate) for appreciation the quality of transmission

The measurements obtained are verified in the laboratory, with the following:

- Agilent E4402B (3 GHz). Spectrum Analyzer.
- Generator Rohde and Schwarz DVB SFQ.
- Demodulator measurement DVB EFA-T Rohde and Schwarz.
- HF generator Hewlett-Packard 8656 B.
- 3 dB coupler measuring Radiall 500-1000 MHz.
- Load of 50 ohm load.

The signals used are supplied by a generator DVB Rohde and Schwarz SFQ. This ensures a perfect control of various parameters characterizing a DVB-T signal and simulates various defects that may occur in transmission. Signal measurement is performed with a spectrum analyzer and Agilent E4402B with a demodulator measures Rohde and Schwarz EFA-T.

B. Channel

In order to validate the performance of the simulator, the first simulation shows the effect of all the propagation channels considered in the case of a SISO transmission (Fig. 2).

The C/N thresholds obtained are approximately 2 dB higher, which is due to the linear channel estimation used instead of using the optimal 2-D Wiener estimation in the equalizer. This is not a significant difference for the comparative study as all the techniques considered use the same equalizer.

We see that the measured values satisfy the theoretical four types of the channels.

C. Simulated BIT-ERROR RATE Diagrams

Below are bit-error rate diagrams for the various modulations, using both short and long FEC codes.

The measures taken have been shown as curves in each case see Fig. 5.

The data in the DVB-T specification which relates to the efficiency of the system are based on simulation results using a Rayleigh channel model (no line-of-sight).

The simulated values are taken in urban areas and then they check in the SNRT laboratory, by the measuring apparatus.

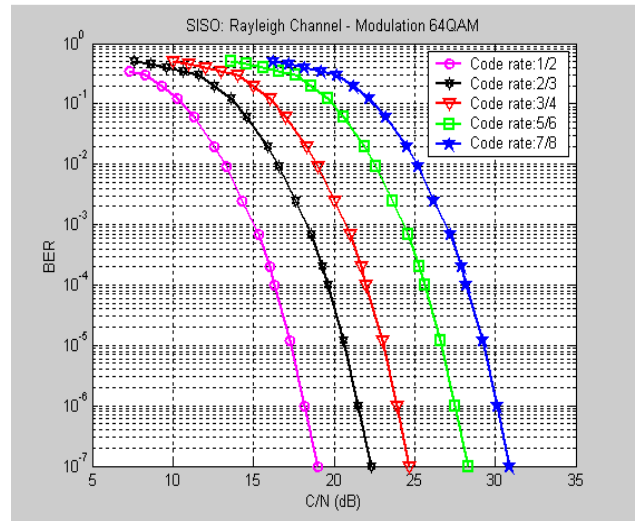

Fig. 5 The BER performance of the 64QAM modulation, Rayleigh Channel con with different values of FEC code in SISO (Nt=1, Nr=1) transmission

We note that the performance of FEC improve the BER that coincides well with the theory. We will work with FEC= 3/4 used in Morocco.

D. Diversity

The effect of diversity on quality reception has been studied by comparing the SISO, MISO and MIMO techniques proposed (Fig. 2) with different diversity configurations (Fig. 3). This is depicted in Fig. 6, and the results for other combinations are summarized in Table I and Table II.

The result is shown in Fig. 6 which makes the comparison between the simulation of the measured values and the results of Alamouti code.

Following Table I gives the comparison result among no diversity, Alamouti's scheme and system MIMO without encoder (Fig. 2) for a particular BER.

Table II gives the comparison result between SISO (no diversity), MIMO Alamouti and MIMO system without encoder for particular C/N.

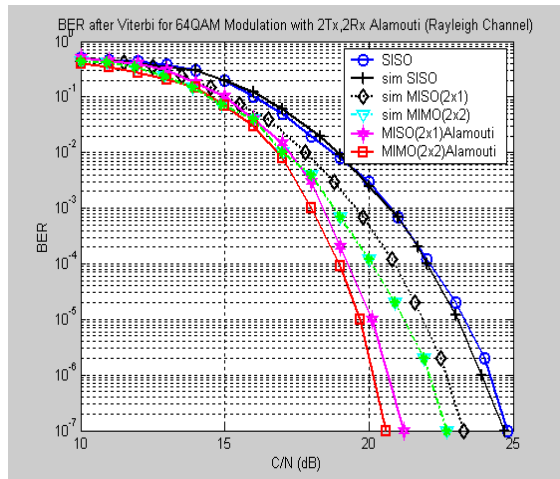

Fig. 6 Comparison of (sim case) and the Alamouti Scheme for 64QAM transmission

TABLE I
 REQUIRED C/N (dB) FOR BER = $2 \cdot 10^{-4}$ AFTER VITERBI

Bit Error Rate (BER)	Diversity Technique	C/N in dB
$2 \cdot 10^{-4}$ After Viterbi	No diversity	21.5
	sim MISO(2x1)	20.41
	sim MIMO(2x2)	19.31
	Alamouti(2Tx,1Rx)	19.01
	Alamouti(2Tx,2Rx)	18.28

TABLE II
 REQUIRED BER FOR C/N = 20dB

C/N in dB	Diversity Technique	Bit Error Rate(BER)
20	No diversity	0.0025
	sim MISO(2x1)	0.000475
	sim MIMO(2x2)	0.0000512
	Alamouti(2Tx,1Rx)	0.0000111
	Alamouti(2Tx,2Rx)	0.00000213

V. CONCLUSION

The performance of Alamouti scheme modified coding and polarization diversity compared to the system without coding MIMO are evaluated under the assumption of 64QAM signals and channel Rayleigh, affected by reflection, detraction and scattering environment.

The comparison provided by the curve in Fig. 6 and the numerical values in Table I and II showed that the system model of the MIMO and OFDM technologies in DVB, can improve the appreciation of the quality of transmission (BER) and C / N.

The experiment result shows that the DVB-T system based on the MIMO technology has better performance when there are more antennas.

REFERENCES

- [1] Yong Soo Cho, Jaekwon Kim, Won Young Yang, Chung G. Kang October 2010 "MIMO-OFDM Wireless Communications with MATLAB®"
- [2] Foschini, G. J., & Gans, M. J, "On the limits of wireless communications in fading environment when using multiple antennas", Wireless Personal Communications, 6, 311–335, 1998.
- [3] Telatar, E, "Capacity of multiple antenna Gaussian channels", AT&T Bell Laboratories, Technical Report 1995.
- [4] L. Chia-Yu, K. Mong-Kai, C. Yi-Hsing Chien "Long Length LDPC Code Construction and the Corresponding Decoder Implementation with

Adjustable Parallelism" Vehicular Technology Conference, 2008. VTC Spring 2008 IEEE, pp: 1423-1427, May 2008.

- [5] "Frame structure channel coding and modulation for a second generation digital terrestrial television broadcasting system (DVB-T2),"DVB Document A122, June 2008.
- [6] W. Zhang, X.G. Xia, K.B. Letaief "Space-Time/Frequency Coding For Mimo-OFDM In Next Generation Broadband Wireless Systems" IEEE Wireless Communications, June 2007
- [7] S. M. Alamouti, "A simple transmit diversity technique for wireless communications," IEEE Journal on Selected Areas in Communications vol. 16, pp. 1451-1458, 1998
- [8] Hyunwook Kim, Jaewoon Kim, Suckchel Yang, Minki Hong, Yoan Shin. "An Effective MIMO-OFDM System for IEEE 802.22 WRAN Channels," IEEE transaction on circuits and systems-II: Express briefs, VOL.55, NO.8, August 2008.
- [9] ETSI EN 302 755 v1.2.1, « Framing structure channel coding and modulation for a second generation digital terrestrial television broadcasting system (DVB-T2) ». Rapport, Oct. 2010.