

# Intelligent Agent Approach to the Control of Critical Infrastructure Networks

James D. Gadze, Niki Pissinou, and Kia Makki

**Abstract**—In this paper we propose an intelligent agent approach to control the electric power grid at a smaller granularity in order to give it self-healing capabilities. We develop a method using the influence model to transform transmission substations into information processing, analyzing and decision making (intelligent behavior) units. We also develop a wireless communication method to deliver real-time uncorrupted information to an intelligent controller in a power system environment. A combined networking and information theoretic approach is adopted in meeting both the delay and error probability requirements. We use a mobile agent approach in optimizing the achievable information rate vector and in the distribution of rates to users (sensors). We developed the concept and the quantitative tools require in the creation of cooperating semi-autonomous subsystems which puts the electric grid on the path towards intelligent and self-healing system.

**Keywords**—Mobile agent, power system operation and control, real time, wireless communication.

## I. INTRODUCTION

CRITICAL infrastructure networks are a set of indispensable networks which include water supply, oil and gas, telecommunications, electrical power, and transportation networks. These important networks span all sectors of the economy of a nation and are therefore the backbone of a nation's economy. The power grid is the network which glues together these critical networks and a high security and reliability is required of it. The power grid, however, is impacted by numerous dynamic disturbances.

Deregulation and other factors such as lack of infrastructure investment due to financial and environmental factors and surging demand of electricity compel the system to be operated close to its thermal and stability limits. The deregulated system therefore has the problem of frequent spread of local disturbances into high impact system wide disturbance which is economically and socially costly. This is seen in recent major grid blackouts in North America and Europe [1].

The complexity of the dynamics and the uncertainties of disturbances in the power grid necessitate the use of semi -

autonomous systems and computational intelligence in its operation and control [2]. Currently, the network is controlled in a central fashion where data is collected from local transmission substations to a central control center. Control decisions are then taken and actuation signals sent to actuators in the local substations. The operator's experience is critical in the analysis of information and the choice of action. This approach has the disadvantage of actuation delay, lack of scalability and robustness.

The goal of this study is to develop alternative control architecture where the power network could be efficiently controlled at the transmission substation level with some upper level oversight. In [3], [4], Amin argue that decision making should be close to the process as possible. The key requirement of this new architecture is to exchange information in a reliable, timely and secure manner among the various decision units.

We propose the spatial decomposition of the network into subsystems (substations and power plants) which have their own sensors, actuators and intelligent controller (semi-autonomous agents).

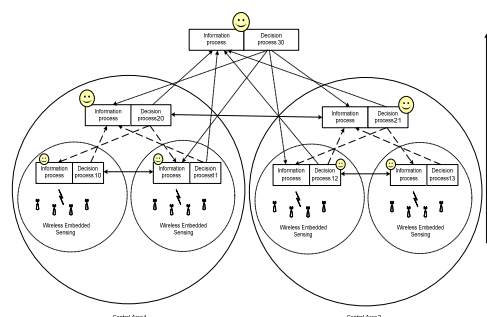

Fig. 1 A generic distributed local level with upper level control

Above this level, intelligent agents are also distributed at regional and system levels (see Fig. 1). The intelligent agent in each subsystem can sense its environment in real time, process the information gathered, take local actions and can cooperate with other subsystems and have higher level supervisory control if necessary. The intelligent agent control concept is thus a notion where the operator's experience is taken out of the control loop and distinct computational units in the decomposed system coordinate to perform control tasks of the electric grid.

The use of dynamic agent-based architecture for power system operation and control was discussed in [5], [6]. However, no specific architecture was proposed. In [7], the

James D. Gadze is a Graduate student with Telecommunication & Information Technology Institute, Florida International University, Miami, FL 33174 USA (phone: 305-348-3987; e-mail: jgadz001@fiu.edu)

Niki Pissinou is a Professor and Director of the Telecommunication & Information Technology Institute, Florida International University, Miami, FL 33174 USA (e-mail: pissinou@fiu.edu).

Kia Makki is a Professor and Co-Director of the Telecommunication & Information Technology Institute, Florida International University, Miami, FL 33174 USA (e-mail: makkik@fiu.edu).

authors proposed the use of a network of distributed cooperating autonomous agents in solving the global problem of eliminating voltage and current violations with a minimum cost of load and generation shedding before protective relays trip. Each agent controls only its local control variable and is allowed to gather measurements from a limited portion of the power system through communication networks. The agent solves a local version of the global problem using model predictive control and cooperation. A very high level of confidence in the method used in predicting system level behavior is required before autonomous agents can be used in high consequence applications such as the control of cascading failures. The objective of shedding load and generation before relays trip seems over ambitious. Our approach incorporates higher level oversight and we consider the action of cooperating semi autonomous agents as a time buying mechanism if substation level agents cannot resolve a problem.

The remainder of the paper is presented in the following order: wireless embedded sensing, substation level state assessment, validation of concept and algorithms and conclusions.

## II. WIRELESS EMBEDDED SENSING

Fundamental to the power grid achieving self healing capabilities, is its ability to make available reliable real time system information to decision units. We propose the use of a wireless communication system to interface the intelligent controller, the sensors and the actuators due to their low cost and easy installation compared to their wired alternatives. The purpose of this section is to provide a real time communication medium for transmission substation agents to perceive their environment. Wireless communication in power system environment is impacted by joint AWGN and impulse noise which severely affect achievable information rates.

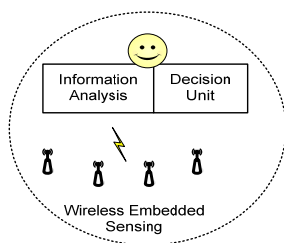

Fig. 2 Wireless embedded sensing

We therefore investigated the general operational impact of impulse noise on multi-user access channel in a power system environment. The key requirements, of any communication network used for sensing and control in power systems are: packet loss constraint, data rate and packet delay guarantees. We adopt a combined networking and information theoretic approach to satisfy these requirements. We seek to maximize rates at which information could be reliably transferred. The classical formulation of this problem is: For a given impulse noise state the maximum rate vector achievable is given by

$$\max_{p \in F_p} \mathbf{R}$$

$$\text{subject to: } \mathbf{E} [\mathcal{P}_i(n)] \leq \bar{p}_i$$

The average power usage for user  $i$  is

$\mathbf{E} [\mathcal{P}_i(n)]$  and is constraint by  $\bar{p}_i$ , the average transmit power of user  $i$ .

We adopt a mobile agent approach rather than the classical approach in optimizing the achievable information rate vector by decomposing the optimization problem where each user has this quantity to maximize.

$$\gamma_i(k) = \frac{h_i p_i}{[(1 - \mu_i) + \mu_i \beta_i(k)] N_0 B}$$

where  $h_i$  is the signal attenuation factor,  $p_i$  the transmit power,  $\mu$  the probability of appearance and  $\beta(k)$  the amplitude of impulse noise. Thus we assumed that each transmitter has a perfect knowledge of the impulse noise information and has an efficient method of controlling its transmit power level. Each user based on the impulse noise condition selects appropriate power level to maintain a predetermined  $\gamma_i$ . The computational unit (Intelligent controller) has a mobile agent which continually visits all users and get their optimized signal to noise ( $\gamma_i(k)$ ) value which is then used in computing the maximum achievable information rate.

Two notions of achievable rates were considered; one where no transmission outage is allowed over all impulse noise states; the second where transmission outage is allowed over subset of the impulse noise states. The former is referred to as the delay limited (zero-outage) capacity and the later the outage capacity. Delay limited (zero-outage) and outage capacity regions are rates achievable with finite coding delay. We quantify the delay limited and outage capacity regions of the impulse noise multiple access channel. The delay limited capacity is the set of rates which satisfy:

$$\Pr \left\{ (R_1, \dots, R_M) : \sum_{i \in S} R_i > B \log_2 \left[ 1 + \sum_{i \in S} \gamma_i(k) \right] \right\} = 0$$

The impulse outage capacity is the rate vector which satisfies:

$$\Pr \left\{ (R_1, \dots, R_M) : \sum_{i \in S} R_i > B \log_2 \left[ 1 + \sum_{i \in S} \gamma_i(k) \right] \right\} \leq \varepsilon$$

The outage probability  $\varepsilon$  may be defined as the fraction of time that the transmission rate is higher than the instantaneous mutual information.

Using queuing theory we develop an equation which can estimate the service speed required by a user when its delay requirement and the queuing state are known. A mobile agent from the intelligent controller continually visits the users and gets their queue state information and application delay requirements. This information is used by our estimator

equation in computing user require rates. For user  $i$  at time  $k$  if the system average delay  $D_i$  is specified and the queuing state of its buffer is known, the encoding rate can be estimated by

$$R_i(k) = \frac{(N_i(k) + 1)}{2D_i}$$

We develop an algorithm to use the characterized zero outage and outage rate regions to provide reliable real time communication service. The allocated rates are distributed by the mobile agent to the users. The following procedures are performed

### Steps

1. From the queue state and delay requirement of users, estimate their respective rates  $r_i$
2. Compute the sum rate  $\sum_{i \in S} r_i$
3. For a given impulse state and power constraint determine the maximum rate vector achievable when no transmission outage is allowed i.e.  $\sum_{i \in S} R_i(k)$
4. Repeat step 3 for all values of  $k$
5. Determine the smallest sum rate  $C_{zero}$  over all impulse noise states
6. All set of rates such that their sum rate is less or equal to  $C_{zero}$  is the zero-outage capacity
7. Is the sum rate in step 2 less or equal to  $C_{zero}$  ?
8. If yes then the specified rates in step 1 could be provisioned without any transmission outage (deterministic QoS)
9. If no
10. Determine the maximum rate vector that can be maintained over all impulse noise states except over a subset of impulse noise states with transmission outage probability of  $\mathcal{E}$ . This is the outage capacity  $C_{outage}$
11. Is the sum rate in step 2 less or equal to  $C_{outage}$
12. If yes then the specified rates in step 1 could be provisioned with transmission outage probability  $\mathcal{E}$  (Statistical QoS)
13. If no increase the outage probability and repeat steps 10 to 12

### III. SUBSTATION LEVEL STATE ASSESSMENT

In this section we develop a method of transforming transmission substations from mere supplier of raw data into information processing, analyzing and decision making unit. Thus we model the activities in a substation and its vicinity in a way to let it exhibit intelligent behavior. The interdependency of activities of components in the substation and its vicinity are captured using the influence model.

The influence model,  $P(t+1) = CS(t)A$ , describes the interaction among several Markov chains and generates a Markov process that models propagation on networks [8]. In

the context of power system transmission networks the operating condition of transmission lines and transformers at any given time are assumed to be either in a 'normal' or 'tripped' state as shown in Fig. 3.

The next state of each chain depends on both its own current state and the state of its neighbors. The influence model is used to describe the influence each chain has on the other and can thus capture the propagation of cascading dynamics in the network. Agents at the substation level would be capable of knowing how the status of components evolves after a failure if both the network influence matrix  $C$  and the local transition probability matrix  $A$  are known.

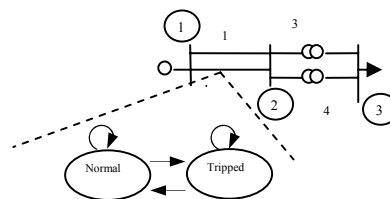

Fig. 3 Transmission component modes

We develop an algorithm to estimate the network influence matrix  $C$  using hidden failure as the main source of influence among transmission components. The method of maximum likelihood is used to estimate the parameters of the local transition probability matrix  $A$ . Our method allows substations to do their own state assessment instead of just providing raw data.

For any given transmission network the network influence matrix can be determined by performing the following procedural steps:

### Steps

1. For line  $i$  determine its neighbors by finding all lines  $j$ , that share bus with it
2. Determine the influence of line  $j$  on line  $i$  by removing line  $j$  from the circuit and run a load flow to measure the percentage overload induced in  $i$  as a result of the removal of line  $j$
3. For a given hidden failure probability  $p$  and the percentage overload obtained in 2, the probability of exposed line  $i$  tripping incorrectly is estimated from Fig. 4.

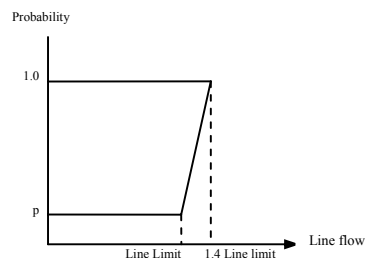

Fig. 4 Probability of exposed line tripping incorrectly [9], [10]

4. For the  $N - (i + j)$  non-neighbors, determine if they have any influence on  $i$  by repeating steps 2 and 3
5. Repeat steps 1 to 4 until  $i = N$  where  $N$  is the total number of sites
6. Use the estimated probabilities to form the network influence matrix  $C$

The one-step transition probability of component  $i$  (changing from time  $t$  to time  $t + 1$ ) can be figured out using

$$p'_i[t + 1] = \sum_{j=1}^N c_{ij} s'_j[t] A$$

where  $c_{ij}$  is an element of the network influence matrix,  $s_j(t)$  is the status of component  $j$  at time  $t$ , and

$$A = \begin{bmatrix} 1 - \beta & \beta \\ \alpha & 1 - \alpha \end{bmatrix}$$

$p'_i[t + 1]$  is a  $1 \times m$  vector and  $m$  is the possible number of statuses a component can reside in. Let each element of  $p'_i[t + 1]$  be denoted by  $p_{iv}$  where  $v = [1, 2, \dots, m]$ . Using the evolution equations of the influence model observe a sequence of network states,  $S_1, S_2, \dots, S_T$ . We use maximum likelihood method [11], [12] in estimating the parameters  $\alpha$  and  $\beta$  of the local transition probability matrix. On knowing the network influence matrix our aim is to estimate the parameters  $\alpha$  and  $\beta$  which maximize the likelihood of the observed sequence of network states. The probability of the observed network state changes can be computed by multiplying the various one-step network state change probabilities over the entire time space. The likelihood function is thus

$$L(\alpha, \beta) = \prod_{t=1}^T \prod_{i=1}^N \prod_{v=1}^m (p_{iv})^{N \cdot s_v[t]}$$

where  $s_v[t]$  is the proportion of components in status  $v$  at time  $t$ .

#### IV. VALIDATION OF CONCEPT AND ALGORITHMS

We characterize the impulse noise delay limited and outage capacities for two users using MATLAB. The two users' communications are impacted by independent random impulse noise. We first determine their individual and sum achievable rates as depicted in Fig. 6 and Fig. 7. From Fig. 7, it is seen that the minimum achievable rate that could be shared by the two users over all impulse conditions is 261 kbps. Multiple access techniques such as time division, frequency division or coding techniques could be used to share the sum rate. The point (261, 0) in Fig. 8 is the achievable rate vector when only

user one is transmitting. The opposite situation is the point (0, 261). Time sharing gives the minimum rate region and we use it as the service rate that we can guarantee. Time sharing gives the rate vectors bounded by the straight line. A rate of 271 kbps is achievable if we allow some transmission outage. The second curve corresponds to an outage probability of 0.17. The zero-outage region is thus 0AB and the outage region is 0CD for two users. As the outage probability increases the achievable sum rate increases as seen in Fig. 8. With the appropriate outage probability, any rate vector selected in these regions would satisfy both the delay and reliability requirements of users.

A 5-bus system as shown in Fig. 5 was used to demonstrate how a substation can exhibit intelligent behavior. The system parameters are chosen such that all lines are loaded close to their limits. The contingency overloads of the test system were obtained using power world simulator and the probability of transmission lines tripping incorrectly due to hidden failure estimated.

We assumed that removal of system components lead to only overloading problem.

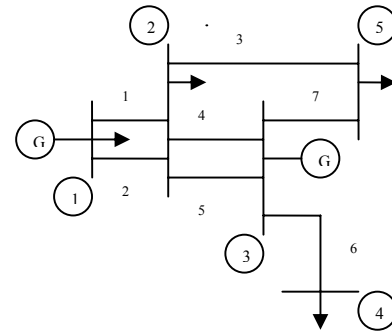

Fig. 5 A 5-bus test system

The network influence matrix of the test system for a worse case load scenario is

$$C = \begin{bmatrix} 0.1 & 0.825 & 0.025 & 0.025 & 0.025 & 0 & 0 \\ 0.825 & 0.1 & 0.025 & 0.025 & 0.025 & 0 & 0 \\ 0.025 & 0.025 & 0.08 & 0.36 & 0.36 & 0 & 0.15 \\ 0.025 & 0.025 & 0.025 & 0.045 & 0.645 & 0.025 & 0.21 \\ 0.025 & 0.025 & 0.025 & 0.645 & 0.045 & 0.025 & 0.21 \\ 0 & 0 & 0 & 0.025 & 0.025 & 0.925 & 0.025 \\ 0 & 0 & 0.025 & 0.42 & 0.42 & 0.025 & 0.11 \end{bmatrix}$$

We assumed each transmission line has the same local transition probability matrix

$$A = \begin{bmatrix} 1 - \beta & \beta \\ \alpha & 1 - \alpha \end{bmatrix} = \begin{bmatrix} 0.7 & 0.3 \\ 0.4 & 0.6 \end{bmatrix}$$

Since  $m$  is 2 in this case the second element of  $p'_i[t + 1]$  is in the range  $\beta < p_{i2} \leq (1 - \alpha)$

i.e.  $0.3 < p_{i2} \leq 0.6$

Thus  $p_{i2} \leq 0.3$  implies line  $i$  is not in the tripped state and  $p_{i2} = 0.6$  means line  $i$  is in the tripped state. The values of  $p_{i2}$  in between these two extremes may be used as an indication of how close a line is to tripping.

If an agent at bus 2 receives a disturbance information that lines 1 and 4 are off and another agent at bus 3 receives an information that lines 1, 4 and 7 are tripped they both can have a sense of how the status of transmission lines in their perceived environments evolve in the next time step as shown in the Tables I and II.

TABLE I  
TRIP PROBABILITY COMPUTED BY AGENT AT BUS 2

Line $i$	2	3	5	6	7
$p_{i2}$	0.55	0.42	0.50	0.31	0.42

TABLE II  
TRIP PROBABILITY COMPUTED BY AGENT AT BUS 3

Line $i$	2	3	5	6
$p_{i2}$	0.55	0.46	0.56	0.32

The semi autonomous agents would use their calculated trip probabilities to determine their local control actions. In a real power system we would have many agents which would have to coordinate among themselves to achieve the global control objective of the system.

We next used  $\alpha = 0.4$  and  $\beta = 0.3$  to generate complete system state of the test network over 4 time steps. We assumed  $\alpha$  and  $\beta$  are not known and used the sequence of observed states to estimate the values of  $\alpha$  and  $\beta$  which gives the maximum likelihood of the observed states.

We compute the value of  $L(\alpha, \beta)$  for several pairs of  $(\alpha, \beta)$  and the plot is shown in Fig. 9. The shape of the curve in Fig. 9 shows that there is a value of  $(\alpha, \beta)$  pair for which the likelihood of the observed sequence of states is a maximum. The maximum likelihood for our observed states occurred at  $\alpha = 0.36$  and  $\beta = 0.3$  which are much close to  $\alpha = 0.4$  and  $\beta = 0.3$  we used in generating the observed states.

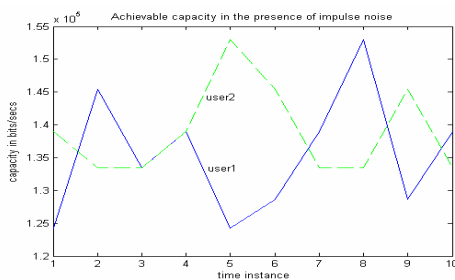

Fig. 6 Individual achievable rates

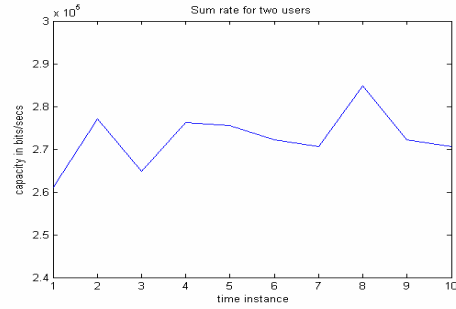

Fig. 7 Achievable sum rate

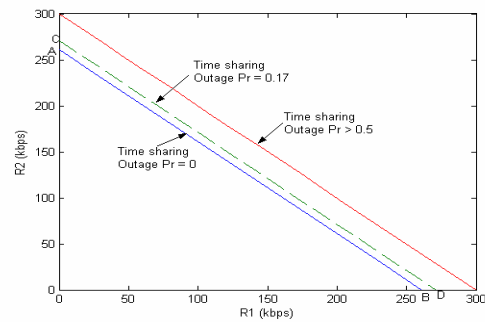

Fig. 8 Zero and non zero outage capacities

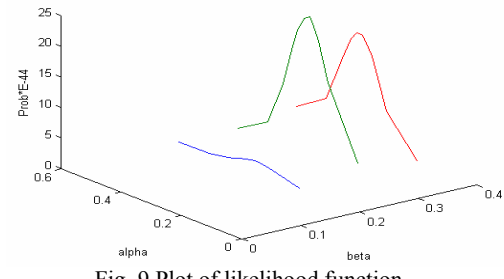

Fig. 9 Plot of likelihood function

## V. CONCLUSION

We developed the concept and quantitative tools architecture which could transform the electric grid into an intelligent infrastructure thereby improving system security and reliability. We presented quantitatively how real time communication of system information and control actions could be achieved through a combined queuing and information theoretic approach. The physical layer consideration is important since communication in wireless medium is not reliable.

We developed a method which equipped transmission substations with the capability of making intelligent decisions instead of just acting as a mere source of raw data. We are in the process of developing a mobile agent based coordination scheme to coordinate local and system level decisions to improve overall security and reliability.

REFERENCES

- [1] US – Canada Power System Outage Task Force, “Final Report on the August 14, Blackout in the United States and Canada: Causes and Recommendations,” April 5, 2004. [www.nerc.com](http://www.nerc.com)
- [2] C. Rehtanz, “Autonomous Systems and Intelligent Agents in Power System Control and Operation,” Springer – Verlag, NY 2003.
- [3] Massoud Amin, “Towards Self-Healing Energy Infrastructure Systems,” IEEE Computer Application in Power, January 2001, pp. 20-28.
- [4] Massoud Amin, “National Infrastructure as Complex Interactive Networks,” In Automation, Control and Complexity: An Integrated Approach. John Wiley & Sons, New York 2000, pp. 263-286.
- [5] A.M Wildberger, “Autonomous Adaptive Agents for Distributed Control of the Electric Power Grid in a Competitive Electric Power Industry,” Proc. of Knowledge-Based Intelligent Electronic Systems, May 21 – 23, 1997, pp. 2 – 11.
- [6] K. Moslehi, A.B. Ranjit Kumar, et al, “Control Approach for Self-Healing Power Systems: A Conceptual Overview,” Presented at the Electricity Transmission in Deregulated Markets: Challenges, Opportunities, and Necessary Research and Development, Carnegie Mellon University, Dec 15 – 16 2004.
- [7] P. Hines, H. Liao, D. Jia, and S. Talukdar, “Autonomous Agents and Cooperation for the Control of Cascading Failures in Electric Grids,” Proc. of the IEEE Conference on Networking, Sensing and Control, 2005.
- [8] C. Asavathiratham, “The Influence Model: A Tractable Representation for the Dynamics of Networked Markov Chains,” Ph.D. Thesis, EECS department, MIT, October 2000.
- [9] Jie Chen, J.S Thorp, and Ian Dobson, “Cascading Dynamics and Mitigation Assessment in Power System Disturbances via a Hidden Failure Model,” International Journal of Electrical Power and Energy Systems, 2003.
- [10] S. Tamronglak, A.G Phadke, S.H Horowitz and J.S Thorp, “Anatomy of Power System Blackouts: Preventive Relaying Strategies,” IEEE Transactions on Power Delivery 1996, 11(2), pp. 708 – 715.
- [11] I.V Basawa, and B.L.S Prakasa, “Probability and Mathematical Statistics: Statistical Inference for Stochastic Processes,” Academic Press, NY 1980.
- [12] Sheldon M. Ross, “Introduction to Probability Models,” Academic Press San Diego, 2004.