

# Containment/Penetration Analysis for the Protection of Aircraft Engine External Configuration and Nuclear Power Plant Structures

Dong Wook Lee, Adrian Mistreanu

**Abstract**—The authors have studied a method for analyzing containment and penetration using an explicit nonlinear Finite Element Analysis. This method may be used in the stage of concept design for the protection of external configurations or components of aircraft engines and nuclear power plant structures. This paper consists of the modeling method, the results obtained from the method and the comparison of the results with those calculated from simple analytical method. It shows that the containment capability obtained by proposed method matches well with analytically calculated containment capability.

**Keywords**—Computer Aided Engineering, CAE, containment analysis, Finite Element Analysis, FEA, impact analysis, penetration analysis.

## I. INTRODUCTION

**S**AFETY is a very important issue for all structural designs. When it comes to aircraft engines and nuclear power plants, it would be one of the most crucial and critical factors to be considered in their design processes.

The commercial aircraft industry is heavily regulated and safety-conscious. In this connection, experimental methods are essential tools for the design and validation of aircraft components [1]. However, these experimental methods are very time-consuming and their costs are high, so that an analysis method which is relatively economical and less time-consuming is proposed in this paper.

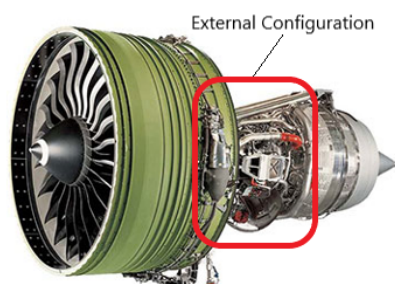

Fig. 1 GE90-115B engine with external configurations [2]

Aircraft engines have complex components and external

Dong Wook Lee, Ph.D. is with the GE-Hitachi Nuclear Energy, Wilmington, NC 28401, USA (corresponding author, phone: 781-771-5135; e-mail: Dongwook.lee@ge.com).

Adrian Mistreanu, Ph.D. is with the GE-Hitachi Nuclear Energy, Wilmington, NC 28401, USA (phone: 910-398-4233; e-mail: Adrian.mistreanu@ge.com).

configurations as shown in Fig. 1, surrounding the engine casing. Fig. 2 shows the turbine blades in the casing, which are rotating at high speed.

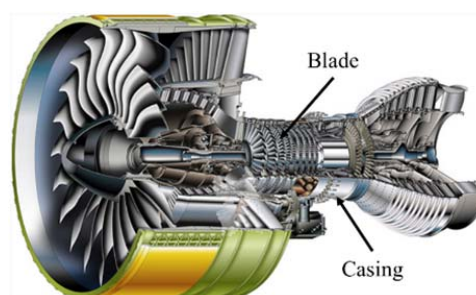

Fig. 2 GE9X engine with external configurations [3]

Failure of the blade can cause catastrophic disaster in terms of human life and economical aspects. Consequently, structural robustness of the engine in an event of the blade failure has always been the long-term concern of each aero engine manufacturer to protect humans and the components. This is called the “containment design”.

The most simple, safe, and reliable experimental testing method in the field of aircraft engine containment design is to make normal impacts on the flat or curved targets using a ballistic gas gun [4]-[7]. But it is limited and restricted because it cannot be applied to test the real engine casings and blades. This paper describes a FEA method based on real turbine and blade model.

Nuclear power plants have nuclear reactors and nuclear fuels that contain a host of radioactive materials by nature. This means these radioactive materials should be confined inside the protecting structure under any circumstances such as foreign object collisions, for this reason it has a containment structure as shown in Fig. 3.

One of the nuclear power plant (NPP) engineering problems is the calculation of the strength and load-bearing capacity under aircraft crash impact. Some researchers studied the strength of NPP structures under aircraft crash impact [9], [10]. But it is virtually impossible to test with real aircrafts. The proposed FEA method is also applicable in the concept design stage to the analysis of NPP and nuclear reactor structures subjected to foreign object collisions such as airplane crash. It is same concept with an aircraft engine containment design in that certain structures should withstand an impact by any foreign object or internal object.

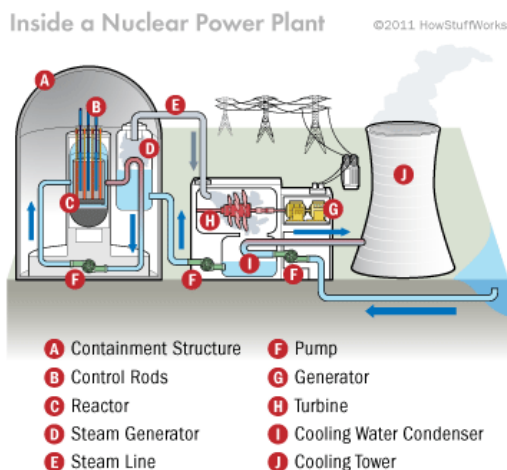

Fig. 3 Nuclear reactor overview [8]

It can be said that aforementioned cases to the aircraft engine containment and NPP structure containment are the same engineering problems, in the sense that a certain structure playing a protection role should be sustainable and functional under the foreign or internal object impact.

This paper proposes a fast and reliable FEA method and its application to example of aircraft engine containment for external configuration is presented.

## II. FINITE ELEMENT MODELING FOR CONTAINMENT ANALYSIS

LS-DYNA, that is one of the explicit Finite Element Analysis program developed by LSTC, was used for this analysis. Fig. 4 shows a simplified mesh model consisting of one casing and one blade, where the blade moves at high lateral speed generated by the high speed rotation of the rotor.

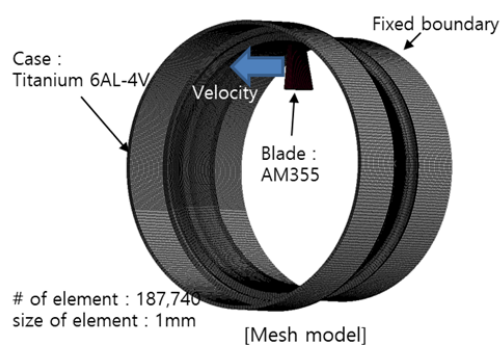

Fig. 4 Mesh model for containment analysis

For the containment analysis, it is important to define proper material properties because we are dealing with a nonlinear phenomenon where the material undergoes plastic deformation. LS-DYNA provides an available input card for various material properties for metal, composites and ceramics, etc. Out of the many material input cards, MAT\_PIECEWISE\_LINEAR\_PLASTICITY card was used for this analysis to provide an ability to use tangent modulus along with elastic modulus which can take into account the simplified plastic zone with linearization as shown in Fig. 5

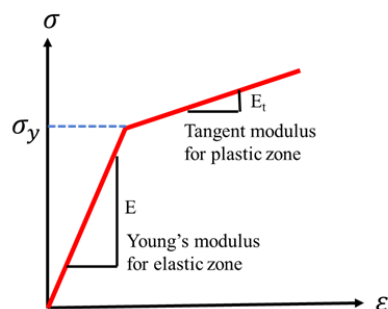

Fig. 5 Young's modulus and tangent modulus

One of the key concepts in this containment analysis is how to model or represent the contact between two objects colliding with each other and even undergoing a penetration phenomenon. For that, LS-DYNA also provides several dozens of input cards in order to represent a variety of contact scenarios. For the containment analysis in this paper, CONTACT\_ERODING\_SURFACE\_TO\_SURFACE is selected where the penetration phenomenon is implemented as follows:

1. When the two elements (one is the blade element and the other is the casing element) are in a contact, we calculate the strain rate for the two elements due to the contact force.
2. If the calculated strain rate is longer than the threshold strain rate which is one of the parameters defined in the LS-DYNA, the element (usually in the casing) would disappear in the FEA model.
3. Then, the not-disappearing element (usually in the blade) would move toward the next casing element to make a contact and then we calculate the strain rate again with the new element.

The penetration phenomenon was described and implemented this way.

Tables I and II show the material properties used for this analysis.

TABLE I

MATERIAL PROPERTIES OF TI-6AL-4V		
Properties	Units	Value
Young's Modulus	Pa	1.14E+11
Yield Stress	Pa	8.80E+8
Poisson's Ratio	N/A	0.342
Tangent Modulus	Pa	3.10E+8
Elongation at Failure	%	10
Density	kg/m <sup>3</sup>	4430

TABLE II

MATERIAL PROPERTIES OF AM355		
Properties	Units	Value
Young's Modulus	Pa	2.00E+11
Yield Stress	Pa	1.17E+9
Poisson's Ratio	N/A	0.29
Tangent Modulus	Pa	1.00E+10
Elongation at Failure	%	20
Density	kg/m <sup>3</sup>	2775

### III. RESULTS OF THE CONTAINMENT ANALYSIS

The results are discussed in this section. The presence of penetration in the casing was checked whenever the analysis was performed by increasing the blade velocity. The rated rotor speed was 46,935 rpm and the blade mass was 9.6 g.

Figs. 6 (a) and (b) show the results of the blade with the given kinetic energy of 573 J generated by the rated rotor speed where there was some plastic deformation but no penetration observed. So, it can be concluded that the case is robust enough for blade with the kinetic energy of 573 J.

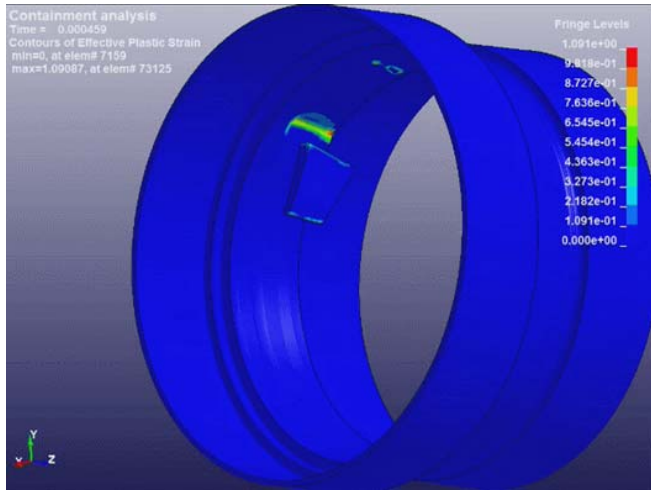

Fig. 6 (a) Result of the containment analysis for the blade under the given kinetic energy of 573 J (inside view)

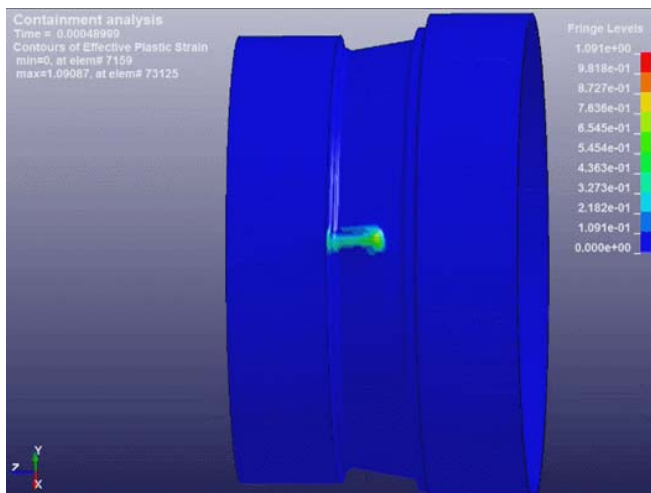

Fig. 6 (b) Result of the containment analysis for the blade under the given kinetic energy of 573 J (outside view)

Figs. 7 (a) and (b) show the results for the blade under the given kinetic energy of 773 J generated by increasing the rated rotor speed by 16%. The structure underwent some plastic deformation but no penetration occurred at this energy level.

Figs. 8 (a) and (b) show the results for the kinetic energy of 816 J generated by increasing the rated rotor speed by 19%. Now we start observing both plastic deformation and penetration. The casing is no longer robust at this increased

level of 816 J.

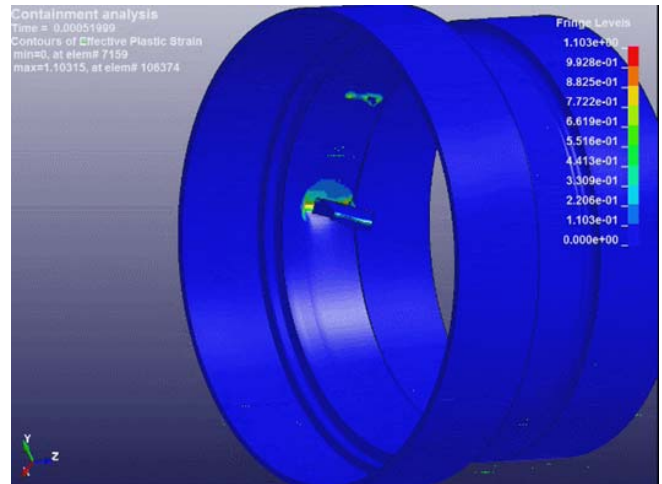

Fig. 7 (a) Result of the containment analysis for the blade under the given kinetic energy of 773 J (inside view)

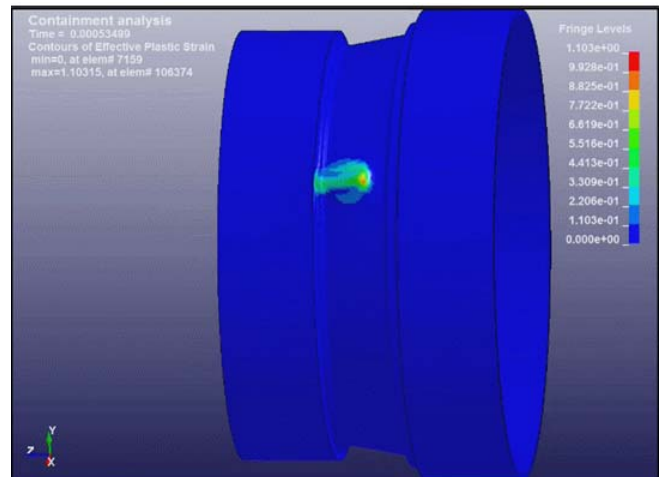

Fig. 7 (b) Result of the containment analysis for the blade under the given kinetic energy of 773 J (outside view)

The containment capability of this casing for the bullet of 9.6 g is 816 J.

The rated rotor speed was increased by 100% to boost the kinetic energy level to 2,292 J. As shown in Figs. 9 (a) and (b), a penetration occurred but blade did not come out and stuck in the case. This means that the blade did not destroy the external configurations around the casing.

Now, the rated rotor speed was increased by 250% to get the energy level of 7,020 J, as shown in Figs. 10 (a) and (b). At this level a penetration occurred and the blade came out of the case. This means the blade destroyed the external configurations at this increased rotor speed. In summary, the containment capability of the casing for the bullet of 9.6 g is 816 J for the given condition.

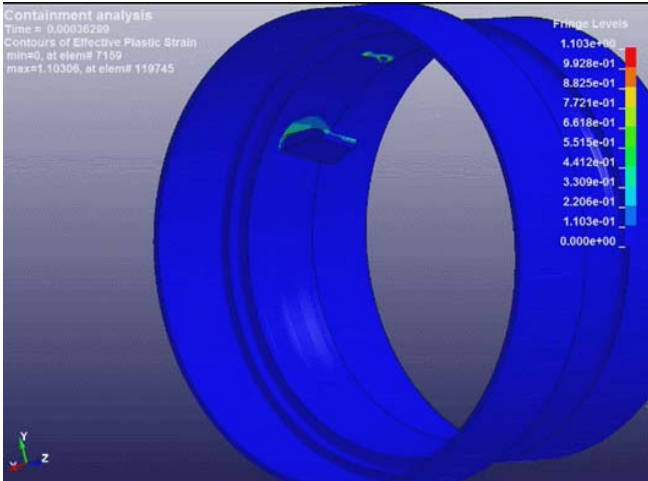

Fig. 8 (a) Result of the containment analysis for the blade under the given kinetic energy of 816 J (inside view)

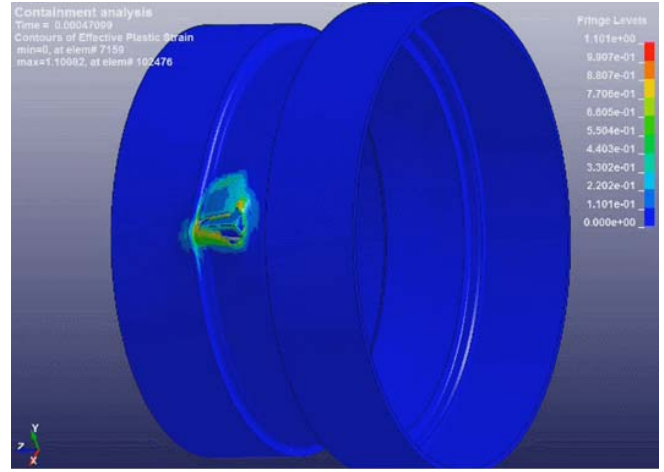

Fig. 9 (b) Result of the containment analysis for the blade under the given kinetic energy of 2,292 J (outside view)

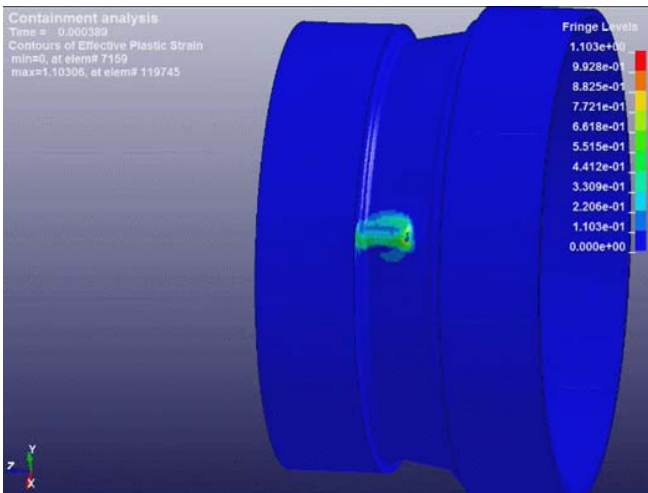

Fig. 8 (b) Result of the containment analysis for the blade under the given kinetic energy of 816 J (outside view)

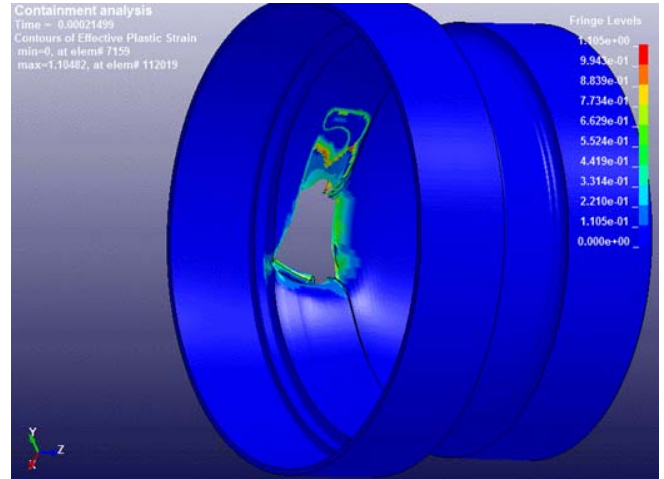

Fig. 10 (a) Result of the containment analysis for the blade under the given kinetic energy of 7,020 J (inside view)

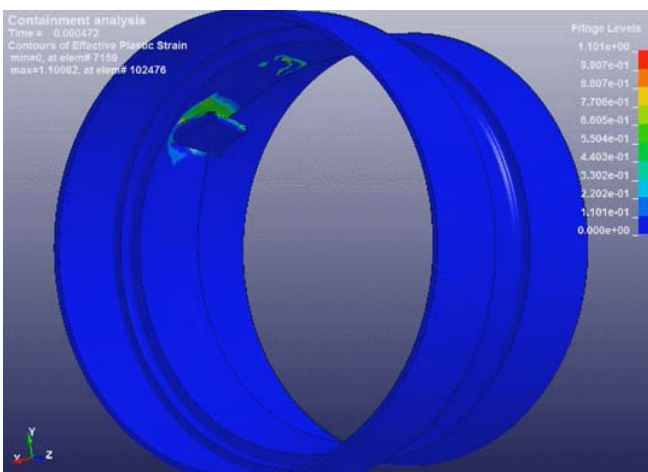

Fig. 9 (a) Result of the containment analysis for the blade under the given kinetic energy of 2,292 J (inside view)

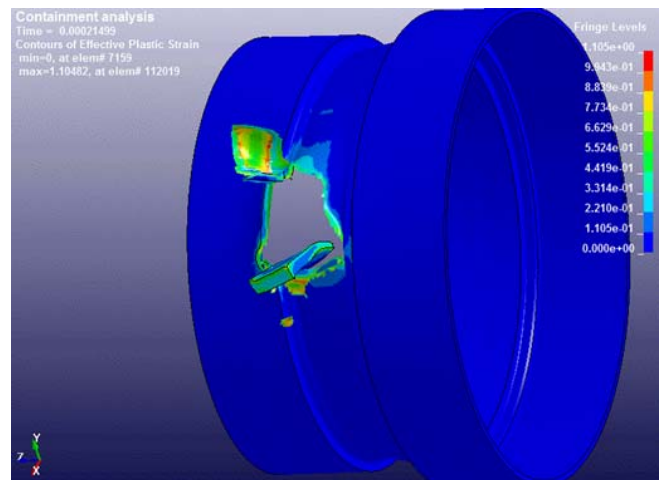

Fig. 10 (b) Result of the containment analysis for the blade under the given kinetic energy of 7,020 J (outside view)

#### IV. COMPARISON OF THE FEA RESULTS WITH SIMPLE ANALYTICAL RESULTS

In this section, we compare our FEA results with those from a simple analytical method based on the calculation of strain energy in the casing induced by an impact. The calculated strain energy is the theoretical prediction of containment capability for the casing.

The concept of the strain energy was used in many fields to predict the energy absorption capability [11]-[14]. Strain energy in material is defined as the energy absorbed by a body due to its deformation. The strain energy per unit volume is called as "strain energy density" which can be obtained by measuring the area under the stress-strain curve towards the point of deformation. The strain energy can then be obtained by multiplying the strain energy density by the strained volume.

Fig. 11 shows a stress and strain curve for Titanium 6AL-4V. The strain energy density is simply the area under the stress-strain curve in the figure.

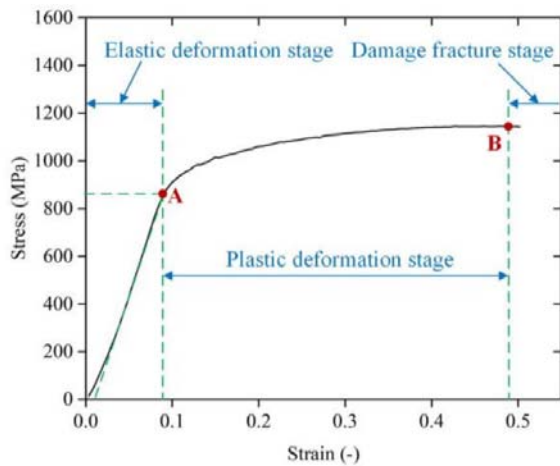

Fig. 11 Stress-strain curve of Ti-6Al-4V alloy in the quasi-static test [15]

The strained volume of the casing can be obtained by multiplying the strained area of the casing by its thickness, the strained area is defined based on the blade contact area as shown in Fig. 12, which is represented by circle area enveloping the blade contact.

The strain energy will be expressed by

$$U = \int \sigma d\epsilon dV = \text{Strain energy density} \times \text{Strained area} \times \text{case thickness} \quad (1)$$

where the strain energy density is  $5.45E+8 \text{ J/m}^3$ , the strained area  $0.000573 \text{ m}^2$ , and the case thickness is  $0.0026 \text{ m}$ . According to (1), total strain energy can be calculated as

$$U = \int \sigma d\epsilon dV = \text{Strain energy density} \times \text{Strained area} \times \text{case thickness} = 5.45E8 \text{ J/m}^3 \times 0.000573 \text{ m}^2 \times 0.0026 \text{ m} = 812 \text{ J}$$

which is well consistent with the results of 816 J from the FEA results.

It seems that the proposed containment analysis method can

be used for the concept design.

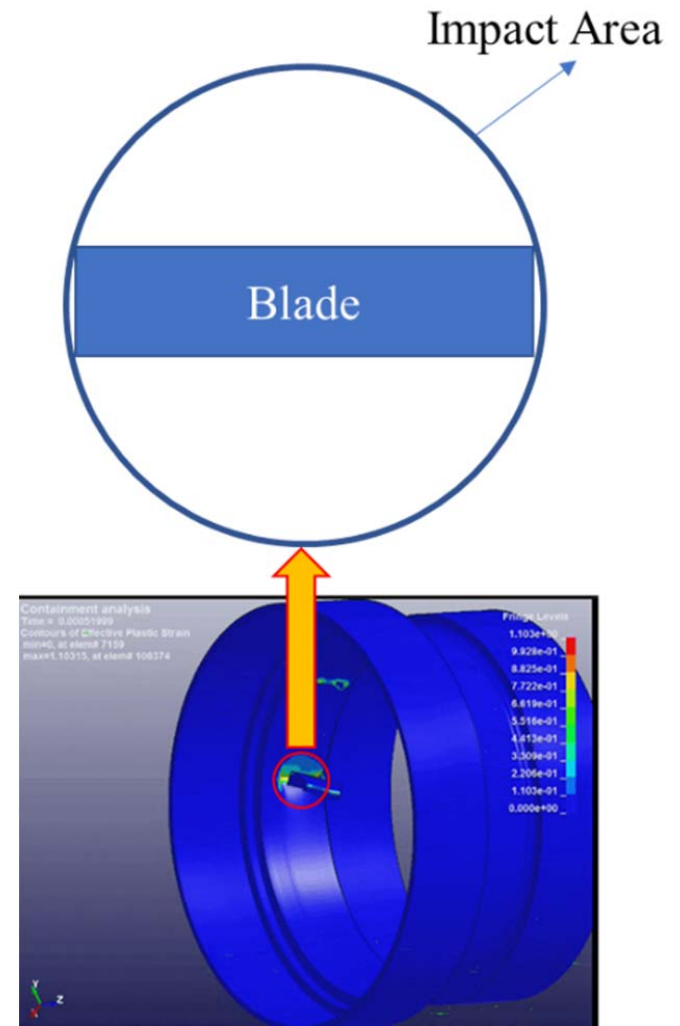

Fig. 12 Definition of impact area to calculate strain energy

#### V. CONCLUSION

An analysis was proposed in this paper based on explicit nonlinear Finite Element Analysis. The proposed method seems promising in the early stage of aircraft engine or NPP design. The results from the FEA technique are in good agreement with the simple analytical calculations but the FEA gives greater flexibility in dealing with the complex structural problems under dynamic conditions and foreign object impact without going into the cost and limitations of the experimental methods. This analysis is based on explicit nonlinear Finite Element Analysis. This paper includes a modeling method, analysis results and a comparison of analysis results with results from simple analytical method. It shows that the containment capability obtained by proposed analysis method is well matched with analytically calculated containment capability.

REFERENCES

- [1] B. Ridley, "Impact Studies of Containment Ring during Blade Shed in Turbofan Engines," Thesis for the degree of Master of Applied Science, Department of Mechanical and Industrial Engineering, University of Toronto, 2018
- [2] <https://www.geaviation.com/commercial/engines/ge90-engine>
- [3] [http://www.planewings.com/news/News\\_Details.aspx?id=301](http://www.planewings.com/news/News_Details.aspx?id=301)
- [4] T. Zhang, W. Chen, Y. Guan, and D. Gao, "Study on titanium alloy TC4 ballistic penetration resistance part I: Ballistic impact tests," *Chinese J. Aeronaut.*, vol. 25, no. 3, pp. 388–395, 2012.
- [5] Q. He, Z. Xie, H. Xuan, and W. Hong, "Ballistic testing and theoretical analysis for perforation mechanism of the fan casing and fragmentation of the released blade," *Int. J. Impact Eng.*, vol. 91, pp. 80–93, 2016.
- [6] G. D. Roberts, D. M. Revilock, W. K. Binienda, W. Z. Nie, S. Ben Mackenzie, and K. B. Todd, "Impact testing and analysis of composites for aircraft engine fan cases," *J. Aerosp. Eng.*, vol. 15, no. April, p. 19, 2002.
- [7] Q. He, Z. Xie, H. Xuan, L. Liu, and W. Hong, "Multi-blade effects on aero-engine blade containment," *Aerosp. Sci. Technol.*, vol. 49, pp. 101–111, 2016.
- [8] <https://science.howstuffworks.com/nuclear-reactor2.htm>
- [9] R.V. Fedorenko, A.A. Kudryavtsev, A.V. Lukin, V.S. Modestove, I.R. Murtazin, "Strength analysis of nuclear power plant structures in case of aircraft crash impact," *Procedia Structural Integrity*, vol. 6, pp. 244-251, 2017
- [10] H. Jiang, M.G. Chorzepa, "Aircraft impact analysis of nuclear safety-related concrete structure: A review," *Engineering Failure Analysis*, vol. 46, pp. 118-133, 2014
- [11] D.W. Lee, Z. Ma, N. Kikuchi, "FOA (First-Order-Analysis) Model of an Expandable Lattice Structure for Vehicle Crash Energy Absorption of an Inflatable Morphing Body," *Journal of Structural Engineering and Mechanics*, vol. 37, no. 6, 2011.
- [12] D.W. Lee, Z. Ma, N. Kikuchi, "An External Explosive Airbag Model for an Innovative Inflatable Bumper (I-Bumper) Concept," SAE 2008 World Congress, Paper No. 2008-01-0508, Included in the book "Side Impact, Rear Impact and Rollover, 2008," ISBN: 978-0-7680-2003-8.
- [13] V.I. Klyashchitskiy, V.I. Golyakov, V.I. Kostylev, B.Z. Margolin, "Strength Analyses of Containment Steel Liner at the Plasticity Instability," *Transactions of the 17th International Conference on Structural Mechanics in Reactor Technology (SMiRT 17) Prague, Czech Republic, August 17–22, 2003.*
- [14] K.S. Carney, J.K. Pereira, D.M. Revilock, P. Matheny, "Jet Engine Fan Blade Containment Using an Alternate Geometry," *International Journal of Impact Engineering*, vol. 36, pp.720-728, 2009
- [15] X. Hou, Z. Liu, B. Wang, W. Lv, X. Liang and Y. Hua, "Stress-Strain Curves and Modified Material Constitutive Model for Ti-6Al-4V over the Wide Ranges of Strain Rate and Temperature," in *Materials*, vol. 11, Issue 6, p. 938, 2018.