

Advanced Palliative Aquatics Care Multi-Device AuBento for Symptom and Pain Management by Sensorial Integration and Electromagnetic Fields: A Preliminary Design Study

J. F. Pollo Gasparly, F. Peron Gasparly, E. M. Simão, R. Concatto Beltrame, G. Orengo de Oliveira, M. S. Ristow Ferreira, J.C. Mairesse Siluk, I. F. Minello, F. dos Santos de Oliveira

Abstract—Background: Although palliative care policies and services have been developed, research in this area continues to lag. An integrated model of palliative care is suggested, which includes complementary and alternative services aimed at improving the well-being of patients and their families. The palliative aquatics care multi-device (AuBento) uses several electromagnetic techniques to decrease pain and promote well-being through relaxation and interaction among patients, specialists, and family members. Aim: The scope of this paper is to present a preliminary design study of a device capable of exploring the various existing theories on the biomedical application of magnetic fields. This will be achieved by standardizing clinical data collection with sensory integration, and adding new therapeutic options to develop an advanced palliative aquatics care, innovating in symptom and pain management. Methods: The research methodology was based on the Work Package Methodology for the development of projects, separating the activities into seven different Work Packages. The theoretical basis was carried out through an integrative literature review according to the specific objectives of each Work Package and provided a broad analysis, which, together with the multiplicity of proposals and the interdisciplinarity of the research team involved, generated consistent and understandable complex concepts in the biomedical application of magnetic fields for palliative care. Results: Aubento ambience was idealized with restricted electromagnetic exposure (avoiding data collection bias) and sensory integration (allowing relaxation associated with hydrotherapy, music therapy, and chromotherapy or

like floating tank). This device has a multipurpose configuration enabling classic or exploratory options on the use of the biomedical application of magnetic fields at the researcher's discretion. Conclusions: Several patients in diverse therapeutic contexts may benefit from the use of magnetic fields or fluids, thus validating the stimuli to clinical research in this area. A device in controlled and multipurpose environments may contribute to standardizing research and exploring new theories. Future research may demonstrate the possible benefits of the aquatics care multi-device AuBento to improve the well-being and symptom control in palliative care patients and their families.

Keywords—Advanced palliative aquatics care, magnetic field therapy, medical device, research design.

I. INTRODUCTION

THE reflections on Palliative Care stimulates a search process for the continuous improvement of the care and management processes of health institutions, focusing on patient safety and obtaining excellent services in order to improve the quality of care itself [1]. This also stimulates the motivation of many health professionals to search for solutions to increase the quality of palliative care through innovation [2].

According to healthcare institutes [3], [4], the use of bioelectromagnetism is already preconized for pain relief in patients, whether oncological or not, as alternative or complement to the use of opioids. Therefore, Pulsed Electromagnetic Fields (PEMF) therapy has several potential advantages, including non-invasiveness, safety, lack of toxicity for normal cells and the possibility of being combined with other available therapies [5], [6]. In this perspective, the therapeutic use of PEMF can be very useful, especially as adjunct palliative therapy. However, there is ambiguity about its inclusion in clinical protocols because still exists lack of scientific credibility [7].

For the modern hospices project, [8] guides the inclusion of a spa and pool environment. According to [9], many modern palliative care institutions have this structure, although the extent and purpose of using pools is still unknown. Actually, there is a Pediatric Palliative Aquatics Program (PPAP) in California. They report that children and their family members involved on PPAP activities declare well-being improvement, relaxation and pain relief. Thus, aquatics palliative care seems

Gasparly JFP is with the MPPC Hospital de Clínicas de Porto Alegre, 90035-903, Porto Alegre, Brazil (phone: +55 51 3359-8000; e-mail: pollogasparly@hotmail.com).

Gasparly FP is with the Architecture and Urbanism Department, Universidade Franciscana, 97010-030, Santa Maria, Brazil (e-mail: fernandaperon@hotmail.com).

Simão EM is with the Physical Department, Universidade Franciscana, 97010-030, Santa Maria, Brazil (e-mail: edersimao@gmail.com).

Beltrame RC is with the Electrical Engineering Department, Universidade Federal de Santa Maria, 97105-900, Santa Maria, Brazil (e-mail: rafaelrcb@gmail.com).

Oliveira GO is with the Science and Mathematical Department, Universidade Franciscana, 97010-030, Santa Maria, Brazil (e-mail: g.orengo@gmail.com).

Ferreira MSR is with the Neuropsychiatric Department, Universidade Federal de Santa Maria, 97105-900, Santa Maria, Brazil (e-mail: fermapsi@gmail.com).

Thies FS is with the Dentistry Department, Faculdade IPENO, 88015-460, Florianópolis, Brazil (e-mail: fernandosartorientista@hotmail.com).

Minello IF is with the Administration Department, Universidade Federal de Santa Maria, 97105-900, Santa Maria, Brazil (e-mail: minelloif@gmail.com).

Oliveira FS is with the MPPC Hospital de Clínicas de Porto Alegre, 90035-903, Porto Alegre, Brazil (e-mail: fesoliveira@hcpa.edu.br).

to be promising as a care program [9].

Faced with the aforementioned contexts, in search of improving the quality of care and clinical research on the therapeutic potential associated with the biomedical application of electromagnetic fields and aquatics environment, the AuBento preliminary design study is presented.

II. LITERATURE REVIEW

In medicine, magnetic fields are used for both diagnostics and adjunctive therapeutic techniques. Methods that use magnetic fields and/or magnetic fluids (CFM) are promising regarding clinical applicability and may reduce treatment cost. The application of CFM is statistically proven to benefit patients in a wide range of diseases, including rheumatologic, musculoskeletal, oncological, neuroendocrine, neurological, and psychiatric disorders, as well as specific relief of symptoms such as pain. Studies have shown that therapeutic action is due to the translation of CFM into a biological signal that triggers a set of physiological and behavioral events. Moreover, it is now undisputed that electromagnetic fields produce biological effects and there are several theoretical hypotheses that seek to explain the physiology of action [10]-[15].

For decades, this technology has been scientifically evaluated in clinical trials, despite the results of its biomedical application being difficult to replicate, generating controversies in its indication in clinical protocols [2]. The complexity of clinical research on the biomedical application of this technology often precludes its replicability and systematic interpretation of results, and the internal and external validity of studies are frequently open to criticism [2], [5], [6], [10]-[14]. There are numerous justifications for this, including selecting research participants, electromagnetic field generating equipment, different possible electromagnetic field sources (AC-generated pulses, DC-generated fields, static, magnetic fluids), different pulsating field frequencies, possible influence of the electromagnetic fields of the environment, and the reflections, more specifically in humans, and the psychological influences, such as the placebo effect and nocebo [2], [5], [6], [13]-[15].

It is possible to have a number of individual variables in relation to the equilibrium point of a human body from the point of view of the subtle energy associated with its biocampus. Physical and mental vitality, age, physical fitness, and the presence of clinical diseases appear to alter an individual's biocampus [16]. As a result, the appropriate frequency and magnetic field used in a clinical study tends to be personalized and not standardized [17], [18]. Environmental variables are other possible complicating biases, since the influence of geomagnetism is not constant everywhere on the planet as there are regional variations [19].

III. METHODS

The methodology for developing this project was the Work Package Methodology [20], characterized by the management

approach based on the division of a process into a series of small tasks defined in Work Packages (WP). This division of labor allowed the exchange of information among the invited members, allowing the degree of specialization required for each area to be shared quickly. The organization was structured in 7 interconnected stages (Fig. 1): WP1, Management and supervision; WP2, Analysis of historical data; WP3, Development of guiding principles to improve the robustness of clinical research; WP4, Ethical requirements and recognition of national and international standards; WP5, Design Experience; WP6, Patent deposit; and WP7, Disclosure of the device and search for investments.



Fig. 1 Preliminary design study WPs

The WP2 (Fig. 2), carried out from an integrative bibliographic review, provided the logic underlying the principles, strategies and models for carrying out the design sketches in WP5, validated by WP3 and WP4. This review supported the identification of all points to standardize the device for an adequate clinical data collection with bias reduction by minimum electromagnetic exposure from the environment and preventing direct contact with the researchers (avoiding the biofield influence from the research team).

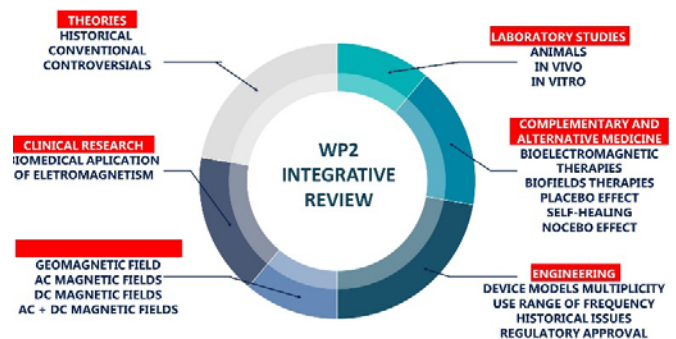

Fig. 2 WP integrative review

Freedom in the creative process allowed innovation (through the inclusion of aqueous colloidal solution and sensory integration to AuBento ambience) registered with the

Brazilian regulatory agency – INPI (Fig. 3).

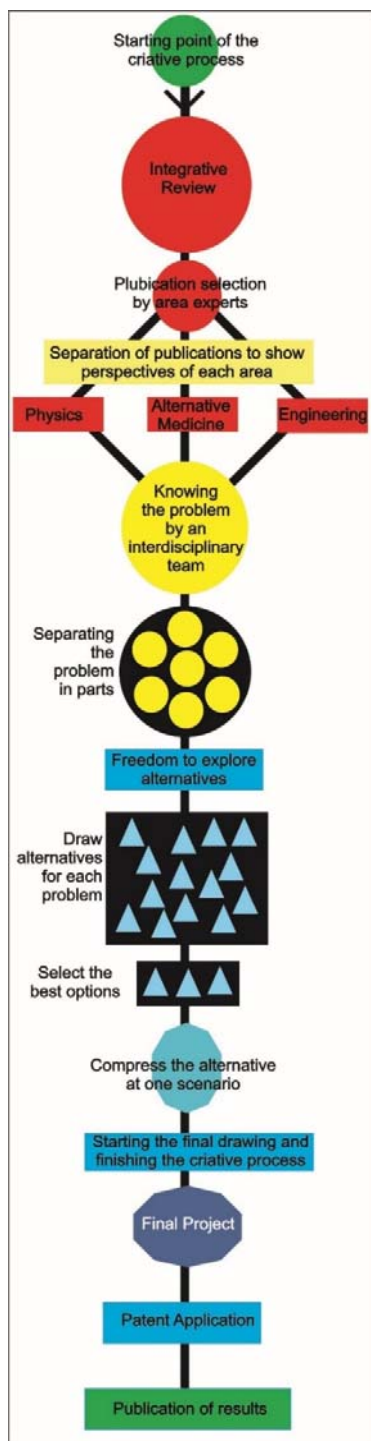

Fig. 3 Creative process

The objectives of each WP are described in Table I.

IV. RESULTS

The Aubento design is presented in an ambience with restricted electromagnetic exposure and sensory integration.

TABLE I
 THE WPS' OBJECTIVES

WP	Objectives
WP1	- Stimulate "Team Up", including new collaborators for adequate interdisciplinary elaboration of the project, preferably in the area of Engineering, Physics and Design capable of contributing to this specific project experience; - Ensure the proper functioning of the project and its completion based on the objectives and schedule outlined initially.
WP2	- Retrospective analysis of grouped historical data; - Assimilate basic concepts involved; - Know theories involved in understanding the therapeutic action; - Explore new concepts and theories for the purpose of innovation; - Recognize the current modi operandi of the biomedical application of electromagnetism with a focus on identifying the diversity of models of medical devices emitting current electromagnetic energy.
WP3	- Develop a generic structure of guiding principles and criteria to support the design experience, in order to design a device capable of increasing the robustness and efficiency of these researches to standardize data collection in order to provide the possibility of future systematic reviews.
WP4	- Increase the quality of the equipment to increase operational security and propose an international standardization for use.
WP5	- Perform the steps of a design experience for product development: Checklist, Diachronic Analysis, Synchronic Analysis, Structural Analysis, Morphological / Ergonomic Analysis and Analysis of the product in relation to use; - Generate the hierarchy of Project Factors; - Carry out the design sketches from the results of WP2, WP3 and WP4; - Describe AuBento, the result of interdisciplinary project experience, at the level of Preliminary Study; - Explore new alternatives for the therapeutic use of AuBento through variations on the biomedical application of Electromagnetism; - Describe the claims for the Clinical Use of AuBento.
WP6	- Compare the Synchronic Analysis of the existing devices performed in WP5 with AuBento to support the originality of the proposal; - Make the patent filing in order to protect the originality of the design experience through one of the exploratory configurations associated with greater innovation; - Deposit the AuBento Deposit Addition Letter to protect the multifunctionality of the new device.
WP7	- Develop texts to be published later to stimulate formal learning through it; - Present the results of this research in environments that integrate the scientific community to allow social learning and the availability of information for researchers worldwide in order to seek investments.

A. AuBento Device

The AuBento setting comprises a set of tanks (T1, T2, and T3) that are interconnected by unidirectional flow piping in a scenario with acoustic isolation and electromagnetic shielding with equipment containing a unit controlled by a computer software and a database containing commands and instructions to activate the peripheral devices (Figs. 4 and 5).

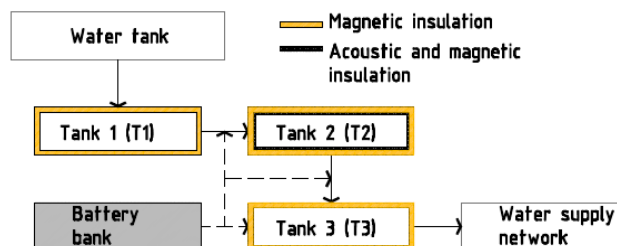

Fig. 4 Schematic flow chart of the support areas and the technical assistance of the scenario of the medical device

In the equipment installation environment, the reduction of electromagnetic exposure occurs through two power lines (in

the equipment selected and near the user): a) alternating current of 220 V (220 Vac) with electromagnetic shielding of powered equipment and b) direct current of 12 V (12 Vdc) (Fig. 6).

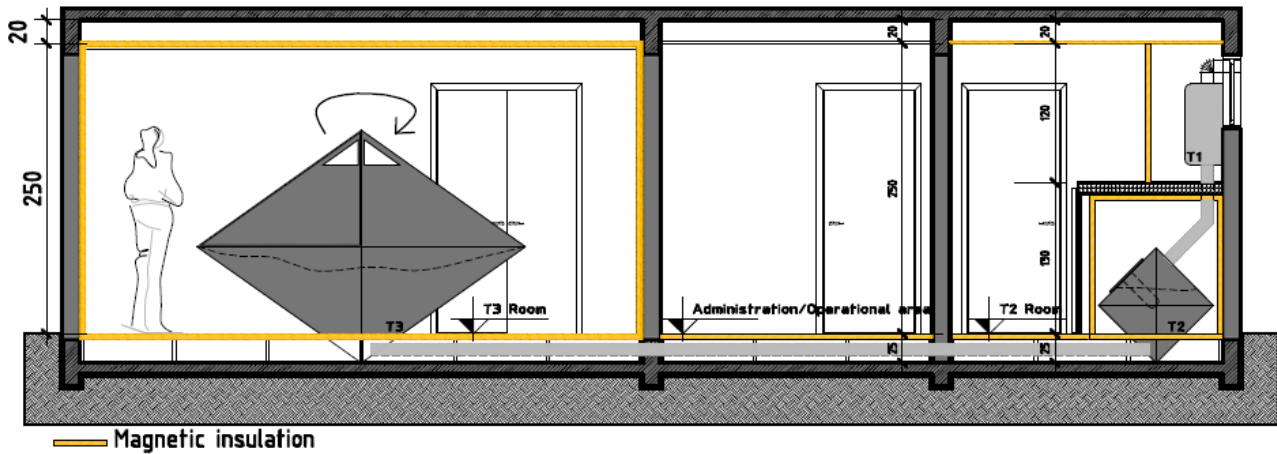

Fig. 5 Sectional view B showing the T2 and its arrangement close to the T1, both arranged in a shared area and magnetically isolated in a suggested architectural design with the minimum configuration expected for device installation.

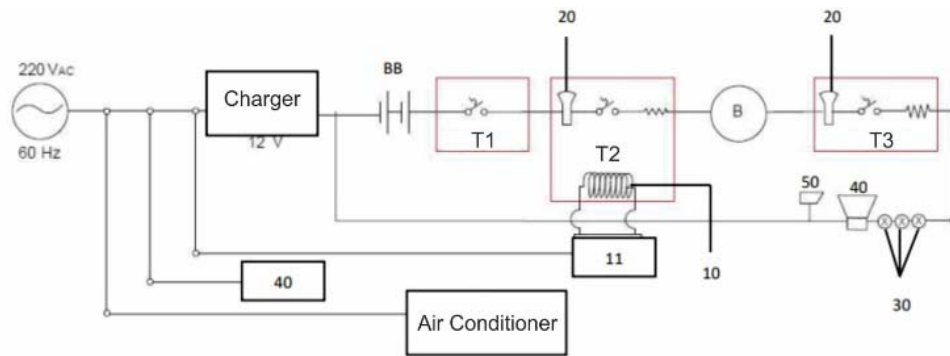

Fig. 6 Schematic electrical diagram of the device

The first tank (T1) comprises a structure suitable for storing an aqueous colloidal solution to be heated in an outdoor unit through a liquid heating unit in order to reach a temperature between 45 °C and 50 °C, which is controlled by a thermostat. Preferably, the aqueous colloidal solution stored in T1 is heated by a coil via a pressure switch that features a sensor that controls the temperature of the colloid and the activation of the valve that controls the passage of gas to the burner. It releases the heated fluid into T1 when the sensor signals to the processor that the previously set temperature has been reached. The heated aqueous colloidal solution is released by piping to the second tank (T2) through communicating vessels, as both are located in close physical spaces in the installation area.

In T2, it is possible to customize the aqueous colloidal solution by adding molecular or ionic colloids that, when mixed with the heated fluid may generate a solution of the sun, emulsion or gel type, according to the researcher's therapeutic objective and interest.

It is also possible to prepare the exposure to electromagnetic fields according to the configuration to be studied. For the generation of the pulsating electromagnetic field (PEMF), a frequency-generating unit comprising an

electromagnetic coil connected to an electromagnetically shielded frequency multi-oscillator is placed inside T2. Optionally, a radio frequency PEMF generating unit may be installed in the internal region of T2, such as (but not limited to) a phanatron connected to the electromagnetically shielded frequency multi-oscillator. Nevertheless, T2 also has an ultra-low voltage power source. Moreover, T2 comprises an octahedron-shaped structure with dimensions 0.70 m by 0.70 m and operational capacity to accumulate 150 l of aqueous solution. It is fixed to the floor under one of the vertices in an environment devoid of illumination and natural ventilation, with soundproofing and electromagnetic shielding, and featuring a top opening protected by a lid. Its structure is composed of multiple alternating layers of unprocessed, chemical-free wood and steel, which is similar to what Wilhelm Reich proposed in the early 1940s [21], [22], functioning as a Faraday Cage. The fluid temperature in T2 is maintained through a thermoregulation system, such as a water bath, which contains electronic temperature control to maintain the temperature at 40 °C. The internal region of T2 contains an underwater sonar that emits an infrasound that generates mechanical waves from 1 Hz to 8 Hz to generate controllable flow in the colloidal solution. The colloid is then

transferred to the third tank (T3) by means of an electromagnetically shielded pipe through a hydraulic pump. The T3 is an octahedron (2 m by 2 m) supported on the magnetically insulated floor under one vertex (Fig. 7). It is capable of holding 150 L of aqueous solution and positioning an individual lying down with the possibility of floating in the fluid, allowing the entire body to be exposed to the aqueous colloidal solution when present. Through its upper opening, there is access to a sliding base (bed) in the internal region of T3. Built similarly to T2, it also has an underwater sonar

inside that emits an infrasound that generates mechanical waves from 1 Hz to 8 Hz to generate the colloidal solution flow, if present according to the chosen configuration. These mechanical waves may also independently stimulate cortical and subcortical responses in brain connectivity [23]. The colloid temperature of 40 °C in T3 is maintained by a thermoregulation system, as in T2. The T3 has natural ventilation at the top. After use, the fluid used in T3 goes to a specific reservoir for treatment.

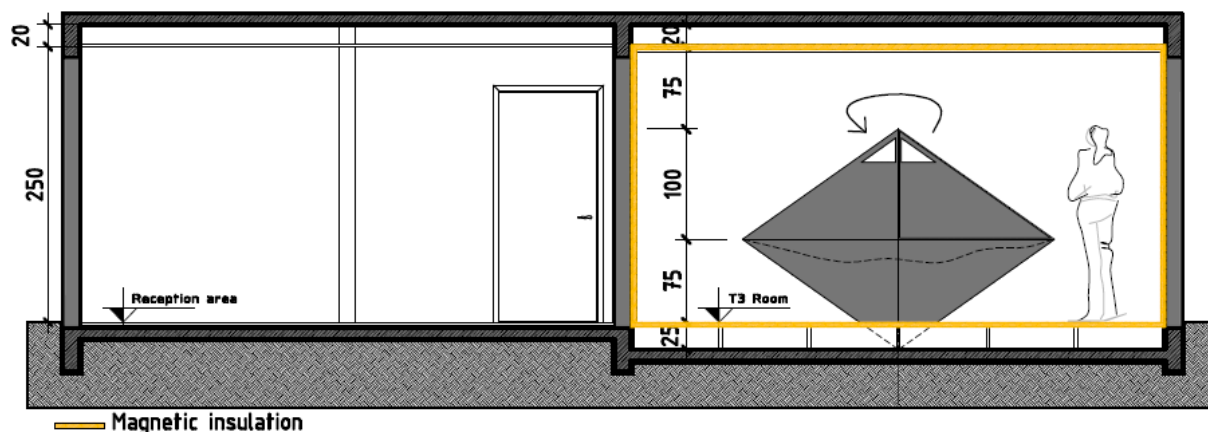

Fig. 7 Sectional view A showing the T3 centered in the main hall of the therapeutic area

The T3 has internal lighting with the possibility of alternating specific shades of blue, violet, and sea green as per the researcher. The lights may be constant or pulsating at the frequency of the researcher's choice. The positioning area of T3 contains a sound system that stimulates sensory integration through music therapy and a unit for image recording.

The research environment also includes the minimum required for administrative and therapeutic flow logistics (Fig. 8), including a reception sector (reception, anteroom, pantry, changing room, and toilet); a support sector (engine room); a therapeutic sector consisting of the T1, T2 and main T3 rooms, and an administrative sector (administration and operational room).

The setting also features soundproof areas and technical flooring. All devices that require power are supplied by a battery bank in the support area or are directly connected to the power grid. Two power sources were used: 220 Vac and 12 Vdc. In addition to the battery bank, the support area includes minimal organization that consists of a central air conditioning unit, sound system, and multi-oscillator that generates power for the coil inserted in the T2. The administration room, locker room, and bathroom are powered by 220 Vac and they are located in electromagnetically shielded areas.

B. AuBento's Possible Configurations

The AuBento scenario comprises an installation configured according to the theoretical hypothesis chosen to be explored. Possible configurations include classic and exploratory (Table II).

TABLE II
 POSSIBLE CONFIGURATIONS OF AU^BENTO SETTINGS

Configuration	Adaptation	Using AuBento	Theory basis
Classic (TMS)	TMS equipment will be included in T3.	T3 + optional use T1 (if hydrotherapy).	TMS
Classic (PEMF)	PEMF equipment will be included in T3.	T3 + optional use T1 (if hydrotherapy).	PEMF
Classic (Magnetic Fluid)	It may be necessary to include PEMF T3 source for fluid routing.	T3 + optional use T1 (if hydrotherapy).	Magnetic Fluid
Exploratory A	No.	T1 + (T2 and T3 in constant connection through colloid).	Magneto-hydrodynamics
Exploratory B	No.	T1 + (T2 and T3 in constant connection through colloid).	Geo-magnetology
Exploratory C	No.	T1 + (T2 and T3 in constant connection through colloid).	Fourth Phase of Water
Exploratory D	No.	T1 + T2 + T3 in sequence use.	Water Memory

C. Classic Configurations

Classic configurations focus on T3 and include the application of PEMF, static electromagnetic fields, magnetic fluids or transcranial magnetic stimulation in an environment with restricted electromagnetic exposure and sensory integration, allowing relaxation associated with music therapy and chromotherapy. It is also possible to include hydrotherapy for relaxation using the non-added aqueous colloidal solution at 40 °C. The adaptations required for each researcher option involve adjustments to T3, such as attaching a robotic arm to position the TMS coil or attaching a specific coil to a moving

arm to emit pulsating or static electromagnetic fields.

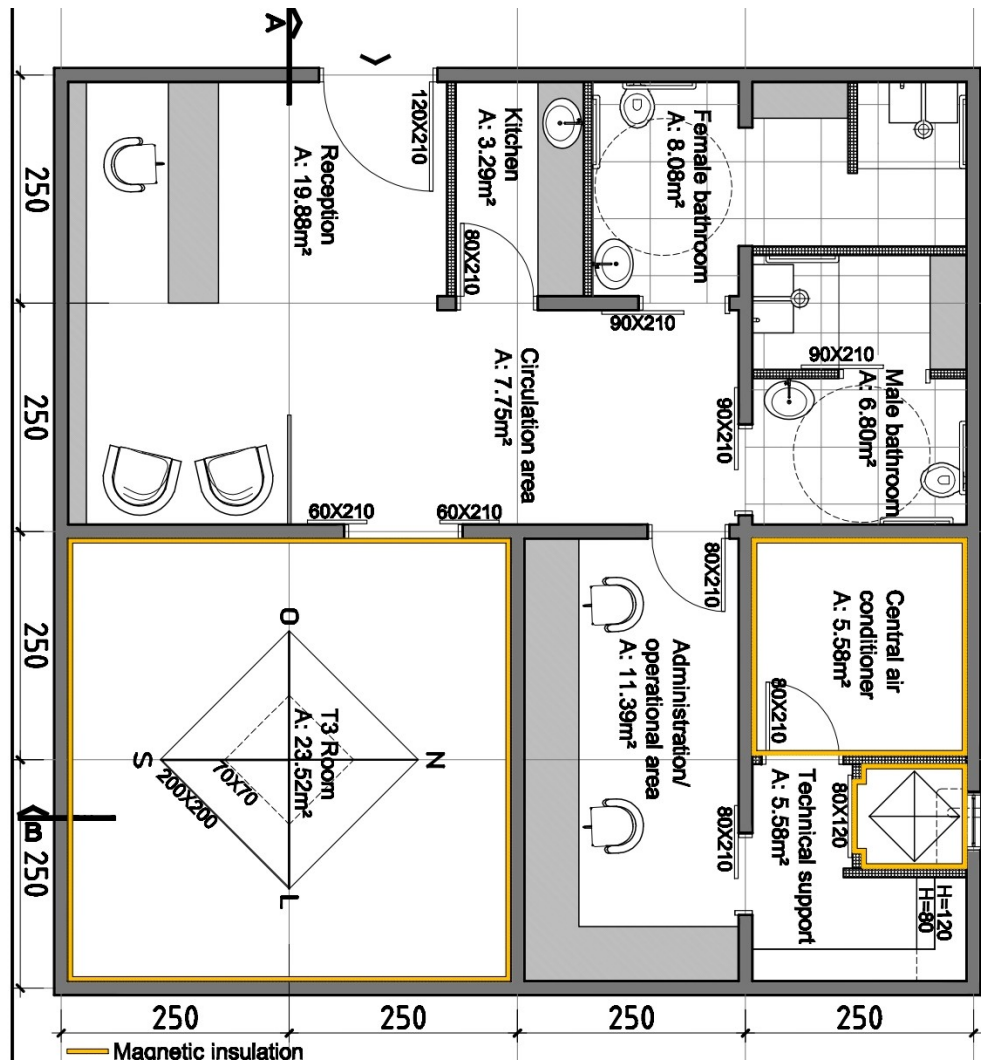

Fig. 8 Floor plan with the minimum configuration expected for the installation of the Device

The advantage of the AuBento device for classic configurations is the restriction of electromagnetic exposure and sensory integration in the research environment.

The so-called exploratory configurations use theories for the device configuration as alternative bases, according to the researcher's interest.

D.Exploratory Configuration A

In this configuration, T2 is used to customize the aqueous colloidal solution by leaving it similar to human plasma. The T2 and T3 are constantly interconnected with the equivalent of 310 l of this solution (150 l for T2, 150 l for T3, and the rest for the connecting pipe). The T2 receives the influence of the chosen electromagnetic field, either pulsating or static, and transfers it to the patient according to the laws of magnetohydrodynamics, such as the Lorentz force [24]. To consider the Lorentz force of a moving particle with velocity v and carrying a charge q , the force acting on the particle is:

$$f = qEs + qEi + q(v \times B)$$

Being E_s the electrostatic field, E_i the induced electric field, and B the magnetic flux density. When E_s and E_i are combined with electric field E , the quantity qE is the so-called electric force, and the equation can be re-written as:

$$f = q(E + v \times B)$$

With this configuration, it is also possible to explore the direct biomedical application of magnetic colloids, even allowing unlimited variations in the colloidal solution making. This configuration provides a possible therapeutic modality: All Body Transcorporeal Magnetic Stimulation (stimulating research on Magnetohydrodynamics) [2].

E. Exploratory Configuration B

In this configuration, T2 and T3 are interconnected as in configuration A, but the aqueous colloidal solution receives ultra-low voltage electrical energy by adapting T2, generating

a weak magnetic field (in micro-Tesla range) arising directly from solution, which may cause changes in the biorhythm [25]-[29]. With this configuration, it is possible to explore the biomedical application of energy variations equivalent to the influence spectrum of geomagnetism. This configuration provides a possible therapeutic modality: All Body Transcorporal Direct Current Stimulation [2].

F. Exploratory Configuration C

It is also possible to explore whether there is a biomedical application of the Fourth Phase Water Theory using the influence of magnetic fluids in contact with the skin of the whole body to stimulate the energy supply in the water molecules that make up the body structure [30]-[32]. Moreover, it will be possible to explore the direct influence of T3 on the patient by generating a possible expansion of the Water Exclusion Zone (EZ water) within the research participant's cells. This configuration provides All Body Transcorporal Magnetic Stimulation enhanced by EZ water [2].

G. Exploratory Configuration D

The T2 and T3 are independent in this configuration. Here, only 160 l of colloidal solution are prepared in T2 and then transferred to T3, according to the researcher's criteria. With this configuration, previously presented [33], it is possible to explore the theory that considers the ability of water to store energy, either electromagnetically or electrically (T2 adapted according to configuration B), and evaluate whether there is biomedical application of this controversial capacity. This theory, according to some researchers, has been conventionally called Water Memory [34], [35].

To explore this concept, the solution is prepared by receiving a predefined charge of electromagnetic field or electric current in a personalized manner according to the patient's set of symptoms. During the session, the patient will not be directly influenced by a new electric field source. He will be floating in the liquid and listening to music. A low frequency of active sonar stimulates patient relaxation and produces fluid flow. When the session ends, the solution is discarded. The process is restarted with each new patient [33]. This configuration provides a possible therapeutic modality: a soft magnetic system and the possibility to research the clinical benefits to use magnetically active colloid [2].

V. DISCUSSION

Several clinical studies, *in vivo* and *in vitro* experiments, suggest that magnetic and electromagnetic fields may accelerate healing processes. Endogenous electromagnetic and magnetic interactions have been reported to be associated with many basic physiological processes, from ion-binding and molecular conformation in the cell membrane to macroscopic tissue changes [5], [6], [10]-[15].

The main reasons why magnetic fields are not widely accepted as the official treatment modalities in medicine seem to be associated to the lack of consensus among scientists about the mechanism of action that explains biological effects.

Analysis of the specific reactions reported for magnetic fields in different biological systems suggests that most observed bioeffects strongly depend on the parameters of the applied electromagnetic field [6]. Given this scenario, control of the research environment favoring the replicability of studies, data interpretation with reduced contaminant biases, and new exploratory options as a result of the addition of colloidal solutions may potentially contribute to clinical research on this subject [2].

In studies on transcranial magnetic stimulation, the combination of relaxation techniques during field exposure have shown to enhance the desired therapeutic response and enhance the reduction of side effects [36]. From this perspective, AuBento device adds sensory integration through hydrotherapy, music therapy, and chromotherapy [2].

In circumstantial terms, the use of water as a healing medium has been described since Greek civilization (around 500 BC). Medical schools were created near bathing places and springs, thus developing aquatic techniques and their use in specific physical treatments. Hippocrates was already using hydrotherapy for patients with rheumatic and neurological disorders, jaundice, as well as for the immersion treatment of muscle spasms and joint diseases (460-375 BC). Many beneficial therapeutic effects are possible through immersion in warm water (such as relaxation, analgesia, and reduced impact and aggression on the joints) [37]. AuBento offers the added benefits of hydrotherapy to any research setup [2].

According to [9], the conclusion of their qualitative study was PPAP gave children access to new capabilities and experiential learning. Through relaxation, children were often viewed as empowered to relieve their own symptoms and explore the world through new sensations and a wider range of abilities during their time in water. This may ultimately lead to children's strengthened feelings of independence. The trust that the participating primary caregivers and children put into the program may have been essential to their achievements. They concluded the economic effect of enrolling pediatric palliative care patients is similar to PPAPs [9]. In addition, music therapy can be beneficial. Several systematic reviews have shown the effects of music therapy in different clinical and therapeutic settings, including the treatment of psychiatric and neurological disorders or anxiety and pain [38]. Furthermore, colors significantly influence the environment by modifying, animating or transforming it. Chromotherapy works directly at the base of the disease and seeks to restore the balance between vibratory energies in the body. Chromotherapy is a science that uses color to establish balance and harmony of body, mind, and emotions, in addition to being used by ancient civilizations [39]. Nevertheless, there are several hypotheses related to magnet reception associated with photoreceptors, such as cryptochrome [25]-[29]. Through chromotherapy available on the device, researchers will be able to explore the stimulation of these receptors during the biomedical application of electromagnetic fields or magnetic fluids [2].

In 1977, Lilly invented the Samadhi Restricted Stimulation Floatation Tank. This device includes benefits such as

relaxation, stress reduction, well-being, transformation of feelings, physical recovery, pain control, and possible meditative states [40]. The T3 can work as a flotation tank if, at the researcher's decision, music therapy is suspended.

VI. CONCLUSION

All health professionals who have been working for a long time have experienced situations of complete or partial refractoriness from standardized clinical treatments. No matter how much a specific clinical protocol is followed, living with refractory cases is common and generates complex emotional demands for everyone involved: the health team, who must deal with the frustration of the limitation of their performance; patients and their families, who need to deal with the reality of the symptoms and diseases that continue to evolve. However, some doctors, faced with this reality and for reasons that are usually the result of empathic reactions, continue to search for something that can be offered to their patients, such as expanding autonomy, dignity, comfort and care quality.

During the search for new therapies with sufficient evidence for their indications, these doctors end up being interested in the practices of Complementary and Alternative Medicine, Integrative Medicine and Palliative Care. Each of these practices represents therapeutic modalities and presents suggestions that generally add positively to your therapeutic arsenal, enabling an increase in the quality of care offered. In addition, the interest in delivering quality health services is a worldwide public health goal. In this perspective, there is potential for the biomedical application of devices that make the clinical use of magnetic fields and fluids available to a wide range of patients. However, clinical research fails to support the clinical indication of bioelectromagnetism for a number of reasons. In order to contribute to enhance methodological rigor in clinical research specifically in this area, an innovative device was developed.

The need to focus on the quality of life of people receiving palliative care is an international issue that might be improved with complementary and alternative treatment approaches. The perspective is to contribute hereafter to the sharing of clinical protocols coming from the various possible configurations using this device. Our aim is to produce evidence on the use of magnetotherapy in aquatics environment to expand the modality of advanced palliative care offered to a range of patients with rheumatic, musculoskeletal, oncological, neuroendocrine, neurological, and psychiatric disorders, in addition to the specific relief of symptoms such as pain. Therefore, it is suggested, for future studies, the validation of the clinical use of AuBento for its therapeutic use.

REFERENCES

[1] Figueiredo DM, Shimizu HE, Ramalho WM, de Figueiredo AM, Lucena KT. Quality of Primary Health Care in Brazil: patients' view. *Rev Bras Enferm.* 2018;71(Suppl 6):2713-9.
[2] Gasparly, JFPG. AuBento's Design Experience: a multipurpose device that uses aqueous colloidal solution for Biomedical Application of Magnetic Fields and Fluids. (Dissertation in portuguese). Hospital de Clínicas de Porto Alegre, Porto Alegre, 2020. 226p

[3] NICE - National Institute for Health and Care Excellence. NICE guideline. Care of dying adults in the last days of life. Published: 16 December 2015. Available in: nice.org.uk/guidance/ng31
[4] North of England Cancer Network Palliative. Palliative and End of Life Care Guidelines. Fourth Edition, 2016. Available in: <http://www.northerncanceralliance.nhs.uk/wp-content/uploads/2018/11/NECNXPALLIATIVEXCAREX2016-1.pdf>
[5] Gordon GA. Designed electromagnetic pulsed therapy: clinical applications. *J Cell Physiol.* 2007;212(3):579-82.
[6] Markov M, Ryaby J, Waldorff E. Pulsed Electromagnetic Fields for Clinical Applications. 1st ed. Local: CRC Press; 2020.
[7] Bernabò N, Ciccarelli R, Greco L, Ordinelli A, Mattioli M, Barboni B. Scientometric study of the effects of exposure to non-ionizing electromagnetic fields on fertility: A contribution to understanding the reasons of partial failure. *PLoS One.* 2017 Dec 6;12(12):e0187890.
[8] Worpole, K. (2009). Modern hospice design: the architecture of palliative care. London: Routledge.
[9] Gaab E, Steinhorn DM. Families' Views of Pediatric Palliative Aquatics: A Qualitative Study. *Pain Manag Nurs.* 2015;16(4):526-533. doi:10.1016/j.pmn.2014.09.012.
[10] Markov MS. Expanding use of pulsed electromagnetic field therapies. *Electromagn Biol Med.* 2007; 26(3):257-74. (PubMed: 17886012).
[11] Salvatore J, Weitberg A, Mehta S. Nonionizing Electromagnetic Fields and Cancer: A Review. *Oncology (Williston Park).* 1996;10(4):563-70. (PubMed: 8723289).
[12] Sert C. Interaction of Electromagnetic Field – Biological System and Three Important Diseases: Cancer, Diabetes and Cardiac Diseases. *JSM Anat Physiol.* 2016; 1(1):1001.
[13] Shupak N, Prato F, Thomas A. Therapeutic uses of pulsed magnetic-field exposure: A review. *URSI Radio Science Bulletin.* 2003; 307:9-32. (doi: 10.23919/URSIRSB.2003. 7909506)
[14] Pasek J, Pasek T, Sieroń-Stołyński K, Cieślak G, Sieroń A. Electromagnetic fields in medicine – the state of art. *Electromagn Biol Med.* 2016; 35(2):170-5. (PubMed: 26192151)
[15] Markov M. Electromagnetic Fields in Biology And Medicine. CRC Press/Taylor & Francis Group, London: 2015.
[16] Rubik B. The biofield hypothesis: its biophysical basis and role in medicine. *J Altern Complement Med.* 2002; 8(6):703-17. (PubMed: 12614524)
[17] Rubik B, Becker RO, Flower RG, Hazlewood CF, Liboff AR, Walleczek J. Bioelectromagnetics applications in medicine. NIH-OAM Electromagnetics Panel Report: 1993.
[18] Blank M, Findl E. Mechanistic Approaches in Interactions of Electric and Electromagnetic Fields with Living Systems. Plenum Press, New York: 1987.
[19] Zhadin MN. Review of Russian literature on biological action of DC and low frequency AC magnetic fields. *Bioelectromagnetics.* 2001; 22(1):27-45. (PubMed: 11122491)
[20] European Commission. The PM² Project Management Methodology Guide 3.0. DIGIT Centre of Excellence in Project Management (CoEPM²), Brussels | Luxembourg, 2018.
[21] DeMeo J. The Orgone Accumulator Handbook Wilhelm Reich's Life-Energy Discoveries and Healing Tools for the 21st Century, with Construction Plans Third Revised and Expanded Edition. Natural Energy Works: 2010.
[22] DeMeo J. Experimental confirmation of the Reich orgone accumulator thermal anomaly. *Subtle Energies & Energy Medicine.* 2009; 20(3):17-32.
[23] Weichenberger M, Bauer M, Kühler R, Hensel J, Forlim CG, Ihlenfeld A, Ittermann B, Gallinat J, Koch C, Kühn S. Altered cortical and subcortical connectivity due to infrasound administered near the hearing threshold – Evidence from fMRI. *PLoS One.* 2017; 12;12(4):e0174420. (PubMed: 28403175)
[24] Davidson PA. An introduction to magnetohydrodynamics. Cambridge texts in applied mathematics. Cambridge Univ. Press, Cambridge: 2001.
[25] Wong JCY, Smyllie NJ, Banks GT, Potheary CA, Barnard AR, Maywood ES, Jagannath A, Hughes S, van der Horst GTJ, MacLaren RE, Hankins MW, Hastings MH, Nolan PM, Foster RG, Peirson SN. Differential roles for cryptochromes in the mammalian retinal clock. *FASEB J.* 2018 Aug;32(8):4302-14. (PubMed: 29561690)
[26] Vanderstraeten J, Burda H. Does magnetoreception mediate biological effects of power-frequency magnetic fields? *Sci. Total Environ.* 2012; 417:299-304. (PubMed: 22071437)
[27] Vanderstraeten J, Gillis P. Theoretical Evaluation of Magnetoreception of Power-Frequency Fields. *Bioelectromagnetics.* 2010; 31(5):371-79.

- (PubMed: 20127890)
- [28] Vanderstraeten J, Verschaeve L, Burda H, Bouland C, Brouwer C. Health effects of extremely low-frequency magnetic fields: reconsidering the melatonin hypothesis in the light of current data on magnetoreception. *J Appl Toxicol.* 2012; 32(12):952-8. (PubMed: 22696437)
- [29] Vanderstraeten J, Burda H, Verschaeve L, Brouwer C. Could Magnetic Fields affect the Circadian Clock Function of Cryptochromes? Testing the Basic premise of the Cryptochrome Hypothesis (ELF Magnetic Fields). *Health Phys.* 2015 Jul;109(1):84-9. (PubMed: 26011501)
- [30] Pollack GH, Figueroa X, Zhao Q. Molecules, Water, and Radiant Energy: New Clues for the Origin of Life. *Int J Mol Sci.* 2009; 10:1419-29. (PubMed: 19468316)
- [31] Ovchinnikova K, Pollack GH. Can Water Store Charge? *Langmuir* 2009; 25:542-7. (PubMed: 19053655)
- [32] Pollack GH. *The Fourth Phase of Water: Beyond Solid, Liquid and Vapor.* Ebner and Sons Publishers: 2013.
- [33] Gasparly J, Gasparly F, Simão EM, Ferreira M, Garcia P, Walty A, Schlatter R, Oliveira F. Exploring the Water Memory hypothesis in a new model of medical device for biomedical applications of Electromagnetic Fields – The “AuBento” new setting. *Book of Abstracts, ICMF: 2019.* (https://premc.org/doc/ICMF2019/ICMF2019_Book_Of_Abstracts.pdf)
- [34] Davenas E, Beauvais F, Amara J, Oberbaum M, Robinzon B, Miadonna A, Tedeschi A, Pomeranz B, Fortner P, Belon P, Sainte-Laudy J, Poitevin B, Benveniste J. Human basophil degranulation triggered by very dilute antiserum against IgE. *Nature.* 1988; 333:816-818. (PubMed: 2455231).
- [35] Kim WH. New Approach Controlling Cancer: Water Memory. *J Vortex Sci Technol.* 2013; 1:1-8. (doi: 10.4172/2090-8369.1000104)
- [36] McClintock SM, Reti IM, Carpenter LL, McDonald WM, Dubin M, Taylor SF, Cook IA, O'Reardon J, Husain MM, Wall C, Krystal AD, Sampson SM, Morales O, Nelson BG, Latoussakis V, George MS, Lisanby SH; National Network of Depression Centers rTMS Task Group; American Psychiatric Association Council on Research Task Force on Novel Biomarkers and Treatments. Consensus Recommendations for the Clinical Application of Repetitive Transcranial Magnetic Stimulation (rTMS) in the Treatment of Depression. *J Clin Psychiatry.* 2018 Jan/Feb;79(1). (PubMed: 28541649)
- [37] Mooventhan A, Nivethitha L. Scientific evidence-based effects of hydrotherapy on various systems of the body. *N Am J Med Sci.* 2014; 6(5):199-209. (PubMed: 24926444)
- [38] Kamioka H, Tsutani K, Yamada M, Park H, Okuizumi H, Tsuruoka K, Honda T, Okada S, Park SJ, Kitayuguchi J, Abe T, Handa S, Oshio T, Mutoh Y. Effectiveness of music therapy: a summary of systematic reviews based on randomized controlled trials of music interventions. *Patient Prefer Adherence.* 2014; 8:727-54. (PubMed: 24876768)
- [39] Azeemi ST, Raza SM. A critical analysis of chromotherapy and its scientific evolution. *Evid Based Complement Alternat Med.* 2005; 2(4):481-8. (PubMed: 16322805)
- [40] Kjellgren A, Westman J. Beneficial effects of treatment with sensory isolation in flotation-tank as a preventive health-care intervention - a randomized controlled pilot trial. *BMC Complement Altern Med.* 2014; 14:417. (PubMed: 25344737)